

VERSIONS	
B	2016-05-04

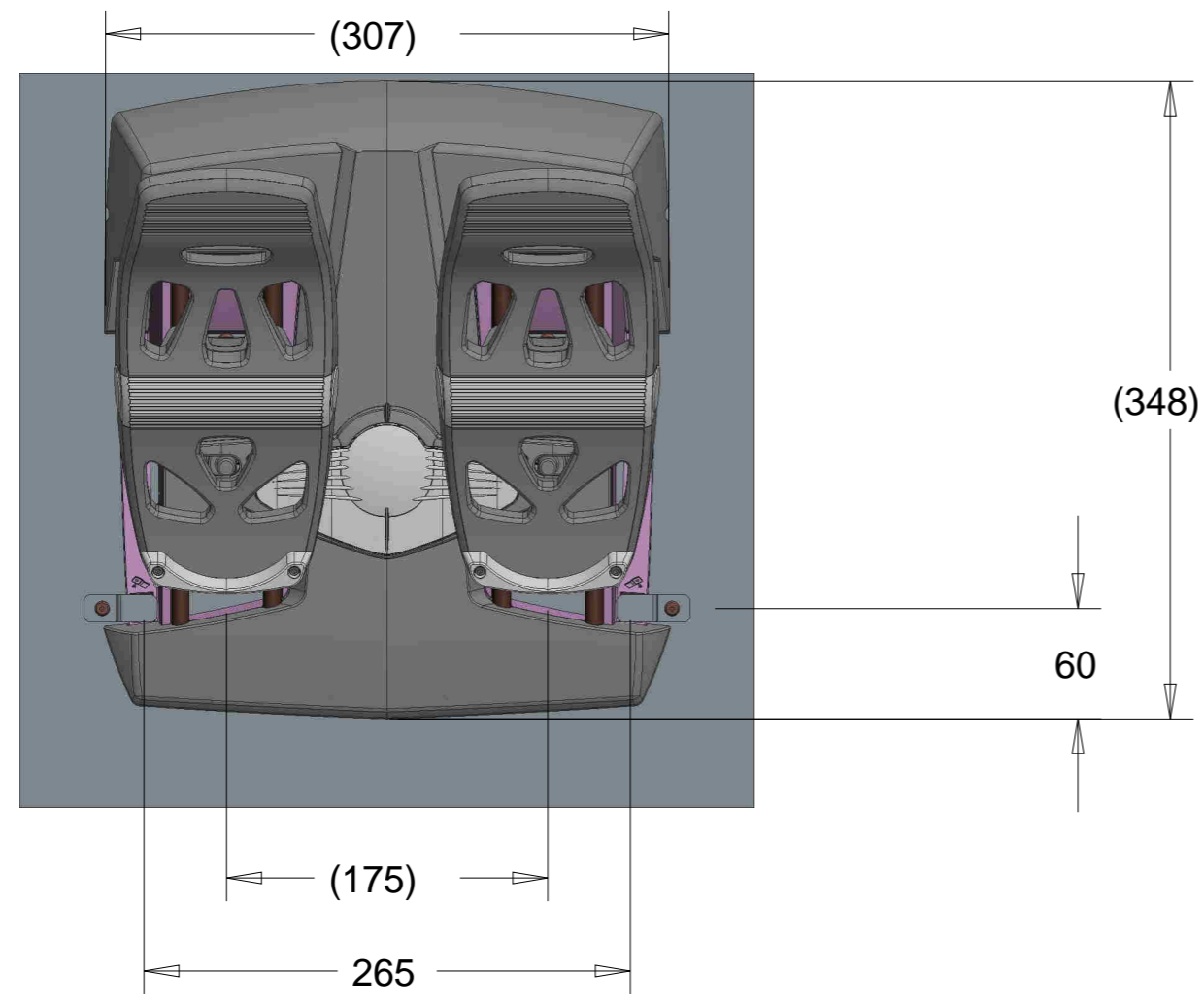

COCKPIT CLAMPING AREA

Clamp example  
(not supplied by THRUSTMASTER)

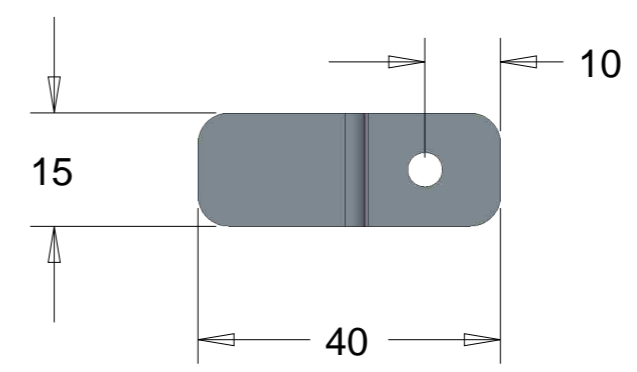

SCALE 1.000

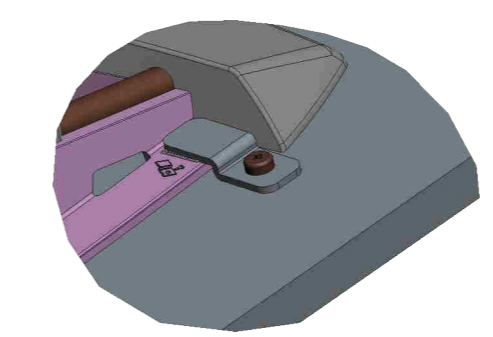
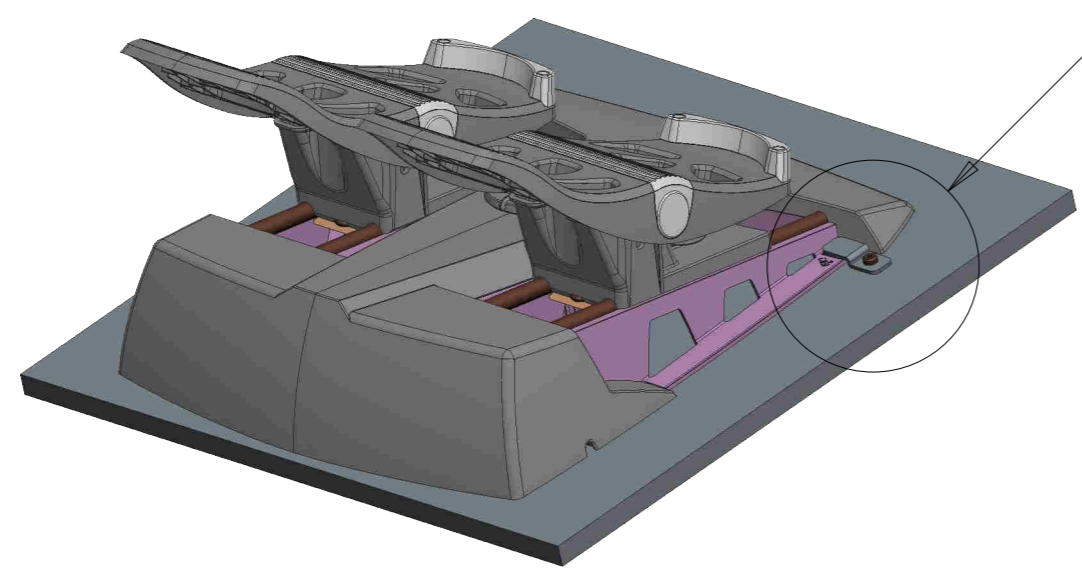

DETAIL A  
SCALE 0.500

MATERIAL	DRAWN BY THRUSTMASTER	DATE 2016-05-04	GUILLEMOT CORPORATION HERCULES THRUSTMASTER	
DIMENSIONAL TOLERANCES UNLESS OTHERWISE SPECIFIED ±1 MILLIMETERS	CHECKED BY	DATE		
	APPROVALS		DWG NO. TM-RU-1-COCKPIT-SETTINGS	SIZE A3
	MASSE N/A		SCALE 0.250	SHEET 1 OF 1
	PLAN			