

ASRock

X570

TAICHI



Version 1.1

Published December 2020

Copyright©2020 ASRock INC. All rights reserved.

Copyright Notice:

No part of this documentation may be reproduced, transcribed, transmitted, or translated in any language, in any form or by any means, except duplication of documentation by the purchaser for backup purpose, without written consent of ASRock Inc.

Products and corporate names appearing in this documentation may or may not be registered trademarks or copyrights of their respective companies, and are used only for identification or explanation and to the owners' benefit, without intent to infringe.

Disclaimer:

Specifications and information contained in this documentation are furnished for informational use only and subject to change without notice, and should not be constructed as a commitment by ASRock. ASRock assumes no responsibility for any errors or omissions that may appear in this documentation.

With respect to the contents of this documentation, ASRock does not provide warranty of any kind, either expressed or implied, including but not limited to the implied warranties or conditions of merchantability or fitness for a particular purpose.

In no event shall ASRock, its directors, officers, employees, or agents be liable for any indirect, special, incidental, or consequential damages (including damages for loss of profits, loss of business, loss of data, interruption of business and the like), even if ASRock has been advised of the possibility of such damages arising from any defect or error in the documentation or product.



This device complies with Part 15 of the FCC Rules. Operation is subject to the following two conditions:

- (1) this device may not cause harmful interference, and
- (2) this device must accept any interference received, including interference that may cause undesired operation.

CALIFORNIA, USA ONLY

The Lithium battery adopted on this motherboard contains Perchlorate, a toxic substance controlled in Perchlorate Best Management Practices (BMP) regulations passed by the California Legislature. When you discard the Lithium battery in California, USA, please follow the related regulations in advance.

“Perchlorate Material-special handling may apply, see www.dtsc.ca.gov/hazardouswaste/perchlorate”

ASRock Website: <http://www.asrock.com>

AUSTRALIA ONLY

Our goods come with guarantees that cannot be excluded under the Australian Consumer Law. You are entitled to a replacement or refund for a major failure and compensation for any other reasonably foreseeable loss or damage caused by our goods. You are also entitled to have the goods repaired or replaced if the goods fail to be of acceptable quality and the failure does not amount to a major failure. If you require assistance please call ASRock Tel : +886-2-28965588 ext.123 (Standard International call charges apply)

The terms HDMI® and HDMI High-Definition Multimedia Interface, and the HDMI logo are trademarks or registered trademarks of HDMI Licensing LLC in the United States and other countries.



CE Warning

This device complies with directive 2014/53/EU issued by the Commission of the European Community.

This equipment complies with EU radiation exposure limits set forth for an uncontrolled environment.

This equipment should be installed and operated with minimum distance 20cm between the radiator & your body.

Operations in the 5.15-5.35GHz band are restricted to indoor usage only.

	AT	BE	BG	CH	CY	CZ	DE
	DK	EE	EL	ES	FI	FR	HR
	HU	IE	IS	IT	LI	LT	LU
	LV	MT	NL	NO	PL	PT	RO
	SE	SI	SK	TR	UK		



Radio transmit power per transceiver type

Function	Frequency	Maximum Output Power (EIRP)
WiFi	2400-2483.5 MHz	18.5 + / -1.5 dbm
	5150-5250 MHz	21.5 + / -1.5 dbm
	5250-5350 MHz	18.5 + / -1.5 dbm (no TPC) 21.5 + / -1.5 dbm (TPC)
	5470-5725 MHz	25.5 + / -1.5 dbm (no TPC) 28.5 + / -1.5 dbm (TPC)
Bluetooth	2400-2483.5 MHz	8.5 + / -1.5 dbm

Contents

Chapter 1 Introduction	1
1.1 Package Contents	1
1.2 Specifications	2
1.3 Motherboard Layout	9
1.4 I/O Panel	11
1.5 WiFi-802.11ax Module and ASRock WiFi 2.4/5 GHz Antenna	13
Chapter 2 Installation	14
2.1 Installing the CPU	15
2.2 Installing the CPU Fan and Heatsink	17
2.3 Installing Memory Modules (DIMM)	25
2.4 Expansion Slots (PCI Express Slots)	29
2.5 Jumpers Setup	32
2.6 Onboard Headers and Connectors	33
2.7 Smart Switches	39
2.8 Dr. Debug	41
2.9 SLI™ and Quad SLI™ Operation Guide	47
2.9.1 Installing Two SLI™-Ready Graphics Cards	47
2.9.2 Driver Installation and Setup	49
2.10 CrossFireX™, 3-Way CrossFireX™ and Quad CrossFireX™ Operation Guide	50
2.10.1 Installing Two CrossFireX™-Ready Graphics Cards	50

2.10.2	Installing Three CrossFireX™-Ready Graphics Cards	52
2.11	M.2_SSD (NGFF) Module Installation Guide (M2_1)	54
2.12	M.2_SSD (NGFF) Module Installation Guide (M2_2)	57
2.13	M.2_SSD (NGFF) Module Installation Guide (M2_3)	60

Chapter 3 Software and Utilities Operation 63

3.1	Installing Drivers	63
3.2	ASRock Motherboard Utility (A-Tuning)	64
3.2.1	Installing ASRock Motherboard Utility (A-Tuning)	64
3.2.2	Using ASRock Motherboard Utility (A-Tuning)	64
3.3	ASRock Live Update & APP Shop	67
3.3.1	UI Overview	67
3.3.2	Apps	68
3.3.3	BIOS & Drivers	71
3.3.4	Setting	72
3.4	Nahimic Audio	73
3.5	Razer Synapse 3	74

Chapter 4 UEFI SETUP UTILITY 77

4.1	Introduction	77
4.1.1	UEFI Menu Bar	77
4.1.2	Navigation Keys	78
4.2	Main Screen	79
4.3	OC Tweaker Screen	80
4.4	Advanced Screen	85
4.4.1	CPU Configuration	86

4.4.2	Onboard Devices Configuration	87
4.4.3	Storage Configuration	89
4.4.4	ACPI Configuration	90
4.4.5	Trusted Computing	91
4.4.6	AMD PBS	92
4.4.7	AMD Overclocking	93
4.4.8	AMD CBS	94
4.5	Tools	95
4.6	Hardware Health Event Monitoring Screen	96
4.7	Security Screen	100
4.8	Boot Screen	101
4.9	Exit Screen	103

Chapter 1 Introduction

Thank you for purchasing ASRock X570 Taichi Razer Edition motherboard, a reliable motherboard produced under ASRock's consistently stringent quality control. It delivers excellent performance with robust design conforming to ASRock's commitment to quality and endurance.

In this documentation, Chapter 1 and 2 contains the introduction of the motherboard and step-by-step installation guides. Chapter 3 contains the operation guide of the software and utilities. Chapter 4 contains the configuration guide of the BIOS setup.



Because the motherboard specifications and the BIOS software might be updated, the content of this documentation will be subject to change without notice. In case any modifications of this documentation occur, the updated version will be available on ASRock's website without further notice. If you require technical support related to this motherboard, please visit our website for specific information about the model you are using. You may find the latest VGA cards and CPU support list on ASRock's website as well. ASRock website <http://www.asrock.com>.

1.1 Package Contents

- ASRock X570 Taichi Razer Edition Motherboard (ATX Form Factor)
- ASRock X570 Taichi Razer Edition Quick Installation Guide
- ASRock X570 Taichi Razer Edition Support CD
- 4 x Serial ATA (SATA) Data Cables (Optional)
- 1 x ASRock WiFi 2.4/5 GHz Antenna
- 1 x ASRock Screwdriver (Optional)
- 3 x Screws for M.2 Sockets (Optional)
- 2 x Standoffs for M.2 Sockets (Optional)

1.2 Specifications

- Platform**
- ATX Form Factor
 - 2oz Copper PCB

- CPU**
- Supports AMD AM4 socket Ryzen™ 2000, 3000, 4000 and 5000 series processors
 - Intersil Digital PWM
 - 16 Power Phase design

- Chipset**
- AMD X570

- Memory**
- Dual Channel DDR4 Memory Technology
 - 4 x DDR4 DIMM Slots
 - AMD Ryzen series CPUs (Vermeer) support DDR4 4666+(OC)/4400(OC)/4300(OC)/4266(OC)/4200(OC)/4133(OC)/4000(OC)/3866(OC)/3800(OC)/3733(OC)/3600(OC)/3466(OC)/3200/2933/2667/2400/2133 ECC & non-ECC, un-buffered memory*
 - AMD Ryzen series CPUs (Matisse) support DDR4 4666+(OC)/4400(OC)/4300(OC)/4266(OC)/4200(OC)/4133(OC)/4000(OC)/3866(OC)/3800(OC)/3733(OC)/3600(OC)/3466(OC)/3200/2933/2667/2400/2133 ECC & non-ECC, un-buffered memory*
 - AMD Ryzen series APUs (Renoir) support DDR4 4666+(OC)/4400(OC)/4300(OC)/4266(OC)/4200(OC)/4133(OC)/4000(OC)/3866(OC)/3800(OC)/3733(OC)/3600(OC)/3466(OC)/3200/2933/2667/2400/2133 ECC & non-ECC, un-buffered memory*
 - AMD Ryzen series CPUs (Pinnacle Ridge) support DDR4 3600+(OC)/3466(OC)/3200(OC)/2933/2667/2400/2133 ECC & non-ECC, un-buffered memory*
 - AMD Ryzen series APUs (Picasso) support DDR4 3466+(OC)/3200(OC)/2933/2667/2400/2133 non-ECC, un-buffered memory*

* For Ryzen Series APUs (Picasso), ECC is only supported with PRO CPUs.

* Please refer to Memory Support List on ASRock's website for more information. (<http://www.asrock.com/>)

* Please refer to page 25 for DDR4 UDIMM maximum frequency support.

- Max. capacity of system memory: 128GB
- Supports Extreme Memory Profile (XMP) memory modules
- 15μ Gold Contact in DIMM Slots

Expansion Slot

AMD Ryzen series CPUs (Vermeer)

- 3 x PCI Express x16 Slots (PCIe1/PCIe3/PCIe4: single at Gen4x16 (PCIe1); dual at Gen4x8 (PCIe1) / Gen4x8 (PCIe3); triple at Gen4x8 (PCIe1) / Gen4x8 (PCIe3) / Gen4x4 (PCIe4))*

AMD Ryzen series CPUs (Matisse)

- 3 x PCI Express x16 Slots (PCIe1/PCIe3/PCIe4: single at Gen4x16 (PCIe1); dual at Gen4x8 (PCIe1) / Gen4x8 (PCIe3); triple at Gen4x8 (PCIe1) / Gen4x8 (PCIe3) / Gen4x4 (PCIe4))*

AMD Ryzen series APUs (Renoir)

- 3 x PCI Express x16 Slots (PCIe1/PCIe3/PCIe4: single at Gen3x16 (PCIe1); dual at Gen3x8 (PCIe1) / Gen3x8 (PCIe3); triple at Gen3x8 (PCIe1) / Gen3x8 (PCIe3) / Gen4x4 (PCIe4))*

AMD Ryzen series CPUs (Pinnacle Ridge)

- 3 x PCI Express x16 Slots (PCIe1/PCIe3/PCIe4: single at Gen3x16 (PCIe1); dual at Gen3x8 (PCIe1) / Gen3x8 (PCIe3); triple at Gen3x8 (PCIe1) / Gen3x8 (PCIe3) / Gen4x4 (PCIe4))*

AMD Ryzen series APUs (Picasso)

- 1 x PCI Express 3.0 x16 Slot (single at x8 (PCIe1))*
- 1 x PCI Express 4.0 x16 Slot (single at x4 (PCIe4))*
- * Supports NVMe SSD as boot disks
- 1 x PCI Express 4.0 x1 Slot

- Supports AMD Quad CrossFireX™, 3-Way CrossFireX™ and CrossFireX™**

** 3-Way CrossFireX™ is only supported with Ryzen Series CPUs (Vermeer, Matisse, Renoir and Pinnacle Ridge).

- Supports NVIDIA® Quad SLI™ and SLI™***
- Supports NVIDIA® NVLink™ with dual NVIDIA® GeForce® RTX series graphics cards***

*** NVIDIA NVLink Bridge does not come with the package. Please purchase it from NVIDIA® if necessary.

*** This feature is only supported with Ryzen Series CPUs (Vermeer, Matisse, Renoir and Pinnacle Ridge).

- 1 x Vertical M.2 Socket (Key E) with the bundled WiFi-802.11ax module (on the rear I/O)
- 15µ Gold Contact in VGA PCIe Slot (PCIe1)

Graphics

- Integrated AMD Radeon™ Vega Series Graphics in Ryzen Series APU*

* Actual support may vary by CPU

- DirectX 12, Pixel Shader 5.0
- Shared memory default 2GB. Max Shared memory supports up to 16GB.

* The Max shared memory 16GB requires 32GB system memory installed.

- Supports HDMI 2.1 with max. resolution up to 4K x 2K (4096x2160) @ 60Hz
- Supports Auto Lip Sync, Deep Color (12bpc), xvYCC and HBR (High Bit Rate Audio) with HDMI 2.1 Port (Compliant HDMI monitor is required)
- Supports HDR (High Dynamic Range) with HDMI 2.1
- Supports HDCP 2.3 with HDMI 2.1 Port

* Picasso supports HDCP 2.2 with HDMI 2.0 Port

- Supports 4K Ultra HD (UHD) playback with HDMI 2.1 Port
- Supports Microsoft PlayReady®

Audio

- 7.1 CH HD Audio with Content Protection (Realtek ALC1220 Audio Codec)
- Premium Blu-ray Audio support
- Supports Surge Protection
- WIMA Audio Capacitors (For Front Outputs)
- ESS SABRE9218 DAC for Front Panel Audio (130dB SNR)

- Pure Power-In
- Direct Drive Technology
- PCB Isolate Shielding
- Impedance Sensing on Rear Out port
- Individual PCB Layers for R/L Audio Channel
- Gold Audio Jacks
- 15 μ Gold Audio Connector
- Nahimic Audio

LAN

- 2.5 Gigabit LAN 10/100/1000/2500 Mb/s
- 1 x Killer® E3100G (PCIe x1 Gigabit LAN 10/100/1000/2500 Mb/s)
- Supports Killer LAN Software
- Supports Killer DoubleShot™ Pro
- Supports Wake-On-LAN
- Supports Lightning/ESD Protection
- Supports Energy Efficient Ethernet 802.3az
- Supports PXE

Wireless LAN

- Killer AX1650x 802.11ax WiFi Module
- Supports IEEE 802.11a/b/g/n/ax
- Supports Dual-Band (2.4/5 GHz)
- Supports Killer WiFi6 802.11ax (2.4Gbps)
- 2 antennas to support 2 (Transmit) x 2 (Receive) diversity technology
- Supports Bluetooth 5.1 + High speed class II
- Supports MU-MIMO
- Supports Killer LAN Software
- Supports Killer DoubleShot™ Pro

Rear Panel I/O

- 2 x Antenna Ports
- 1 x PS/2 Mouse/Keyboard Port
- 1 x HDMI Port
- 1 x Optical SPDIF Out Port
- 1 x USB 3.2 Gen2 Type-A Port (10 Gb/s) (Supports ESD Protection)
- 1 x USB 3.2 Gen2 Type-C Port (10 Gb/s) (Supports ESD Protection)

- 4 x USB 3.2 Gen1 Ports (Supports ESD Protection)
- * Ultra USB Power is supported on USB_12 ports.
- * ACPI wake-up function is not supported on USB_12 ports.
- 2 x USB 2.0 Ports (Supports ESD Protection)
- 1 x RJ-45 LAN Port with LED (ACT/LINK LED and SPEED LED)
- 1 x Clear CMOS Button
- 1 x BIOS Flashback Button
- HD Audio Jacks: Rear Speaker / Central / Bass / Line in / Front Speaker / Microphone (Gold Audio Jacks)

Storage

- 8 x SATA3 6.0 Gb/s Connectors, support RAID (RAID 0, RAID 1 and RAID 10), NCQ, AHCI and Hot Plug
- 1 x Hyper M.2 Socket (M2_1), supports M Key type 2242/2260/2280 M.2 SATA3 6.0 Gb/s module and M.2 PCI Express module up to Gen4x4 (64 Gb/s) (with Vermeer and Matisse) or Gen3x4 (32 Gb/s) (with Renoir, Pinnacle Ridge and Picasso)*
- 1 x Hyper M.2 Socket (M2_2), supports M Key type 2260/2280 M.2 PCI Express module up to Gen4x4 (64 Gb/s)*
- 1 x Hyper M.2 Socket (M2_3), supports M Key type 2260/2280/22110 M.2 SATA3 6.0 Gb/s module and M.2 PCI Express module up to Gen4x4 (64 Gb/s)*
- * If M2_3 is occupied, PCIE4 slot will be disabled
- * Supports NVMe SSD as boot disks
- * Supports ASRock U.2 Kit

Connector

- 1 x SPI TPM Header
- 1 x Power LED and Speaker Header
- 2 x RGB LED Headers
- * Support in total up to 12V/3A, 36W LED Strip
- 2 x Addressable LED Headers
- * Support in total up to 5V/3A, 15W LED Strip
- 1 x CPU Fan Connector (4-pin)
- * The CPU Fan Connector supports the CPU fan of maximum 1A (12W) fan power.
- 1 x CPU/Water Pump Fan Connector (4-pin) (Smart Fan Speed Control)
- * The CPU/Water Pump Fan supports the water cooler fan of maximum 2A (24W) fan power.

- 4 x Chassis/Water Pump Fan Connectors (4-pin) (Smart Fan Speed Control)
- * The Chassis/Water Pump Fan supports the water cooler fan of maximum 2A (24W) fan power.
- * CPU_FAN2/WP_3A, CHA_FAN1/WP, CHA_FAN2/WP, CHA_FAN3/WP and CHA_FAN4/WP can auto detect if 3-pin or 4-pin fan is in use.
- * CPU_FAN2/WP_3A supports the water cooler fan of maximum 3A (36W) fan power.
- 1 x 24 pin ATX Power Connector (Hi-Density Power Connector)
- 2 x 8 pin 12V Power Connectors (Hi-Density Power Connector)
- 1 x Front Panel Audio Connector (15 μ Gold Audio Connector)
- 1 x Thunderbolt AIC Connector (5-pin) (Supports ASRock Thunderbolt 3 AIC R2.0 Card only)
- 2 x USB 2.0 Headers (Support 4 USB 2.0 ports) (Supports ESD Protection)
- 2 x USB 3.2 Gen1 Headers (Support 4 USB 3.2 Gen1 ports) (Supports ESD Protection)
- 1 x Front Panel Type C USB 3.2 Gen2 Header (Supports ESD Protection)
- 1 x Dr. Debug with LED
- 1 x Power Button with LED
- 1 x Reset Button with LED
- 1 x Clear CMOS Button

BIOS Feature

- AMI UEFI Legal BIOS with GUI support
- Supports “Plug and Play”
- ACPI 5.1 compliance wake up events
- Supports jumperfree
- SMBIOS 2.3 support
- CPU, CPU VDDCR_SOC, DRAM, VPPM, PREM VDD_CLDO, PERM VDDCR_SOC, +1.8V, VDDP Voltage Multi-adjustment

Hardware Monitor

- Temperature Sensing: CPU, CPU/Water Pump, Chassis, Chassis/Water Pump Fans
- Fan Tachometer: CPU, CPU/Water Pump, Chassis, Chassis/Water Pump Fans
- Quiet Fan (Auto adjust chassis fan speed by CPU temperature): CPU, CPU/Water Pump, Chassis, Chassis/Water Pump Fans
- Fan Multi-Speed Control: CPU, CPU/Water Pump, Chassis, Chassis/Water Pump Fans
- Voltage monitoring: +12V, +5V, +3.3V, CPU Vcore, CPU VD-DCR_SOC, DRAM, VPPM, PREM VDDCR_SOC, +1.8V, VDDP

OS

- Microsoft® Windows® 10 64-bit

Certifications

- FCC, CE
- ErP/EuP ready (ErP/EuP ready power supply is required)

* For detailed product information, please visit our website: <http://www.asrock.com>



Please realize that there is a certain risk involved with overclocking, including adjusting the setting in the BIOS, applying Untied Overclocking Technology, or using third-party overclocking tools. Overclocking may affect your system's stability, or even cause damage to the components and devices of your system. It should be done at your own risk and expense. We are not responsible for possible damage caused by overclocking.

1.3 Motherboard Layout

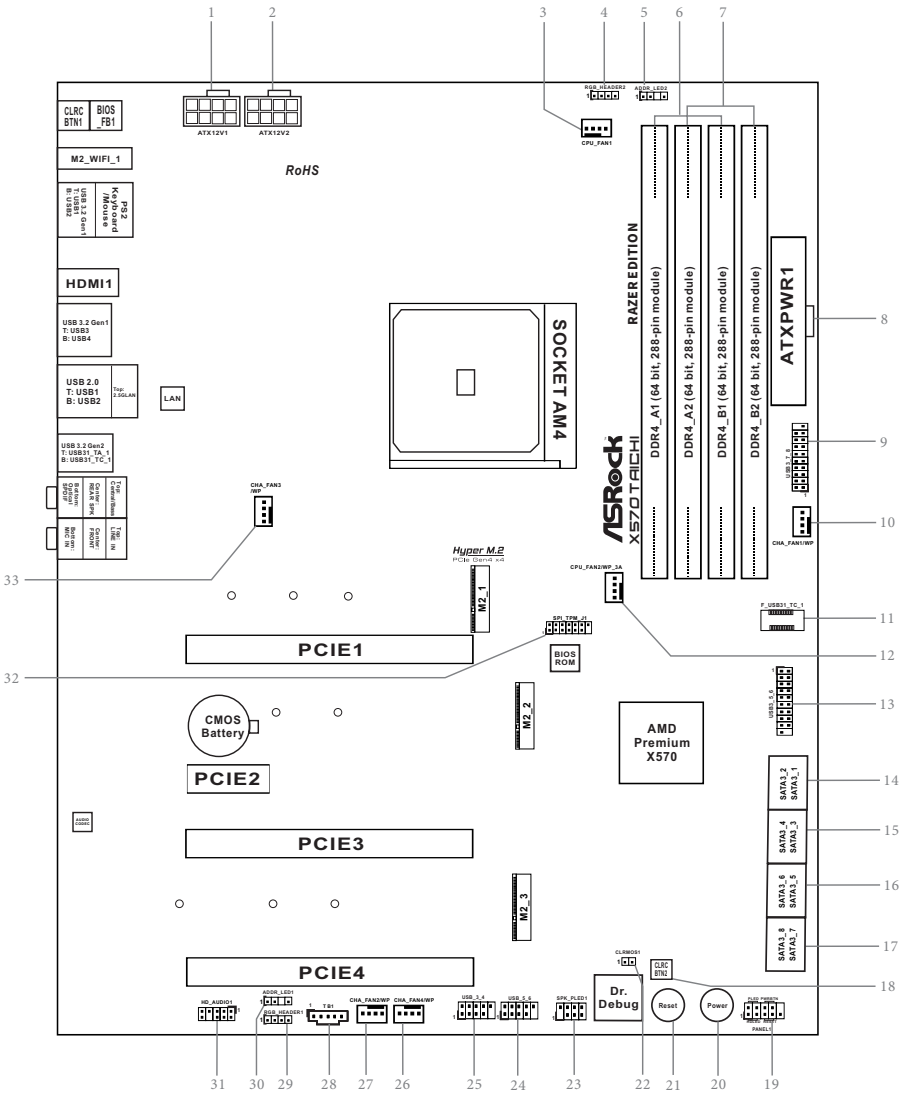

No.	Description
1	8 pin 12V Power Connector (ATX12V1)
2	8 pin 12V Power Connector (ATX12V2)
3	CPU Fan Connector (CPU_FAN1)
4	RGB LED Header (RGB_HEADER2)
5	Addressable LED Header (ADDR_LED2)
6	2 x 288-pin DDR4 DIMM Slots (DDR4_A1, DDR4_B1)
7	2 x 288-pin DDR4 DIMM Slots (DDR4_A2, DDR4_B2)
8	ATX Power Connector (ATXPWR1)
9	USB 3.2 Gen1 Header (USB3_7_8)
10	Chassis / Waterpump Fan Connector (CHA_FAN1/WP)
11	Front Panel Type C USB 3.2 Gen2 Header (F_USB31_TC_1)
12	CPU/Water Pump Fan Connector (CPU_FAN2/WP_3A)
13	USB 3.2 Gen1 Header (USB3_5_6)
14	SATA3 Connectors (SATA3_2) (Upper), (SATA3_1)(Lower)
15	SATA3 Connectors (SATA3_4) (Upper), (SATA3_3)(Lower)
16	SATA3 Connectors (SATA3_6) (Upper), (SATA3_5)(Lower)
17	SATA3 Connectors (SATA3_8) (Upper), (SATA3_7)(Lower)
18	Clear CMOS Button (CLRBTN2)
19	System Panel Header (PANEL1)
20	Power Button (PWRBTN1)
21	Reset Button (RSTBTN1)
22	Clear CMOS Jumper (CLRCMOS1)
23	Power LED and Speaker Header (SPK_PLED1)
24	USB 2.0 Header (USB_5_6)
25	USB 2.0 Header (USB_3_4)
26	Chassis/Water Pump Fan Connector (CHA_FAN4/WP)
27	Chassis/Water Pump Fan Connector (CHA_FAN2/WP)
28	Thunderbolt AIC Header (TB1)
29	RGB LED Header (RGB_HEADER1)
30	Addressable LED Header (ADDR_LED1)
31	Front Panel Audio Header (HD_AUDIO1)
32	SPI TPM Header (SPI_TPM_J1)
33	Chassis/Water Pump Fan Connector (CHA_FAN3/WP)

1.4 I/O Panel

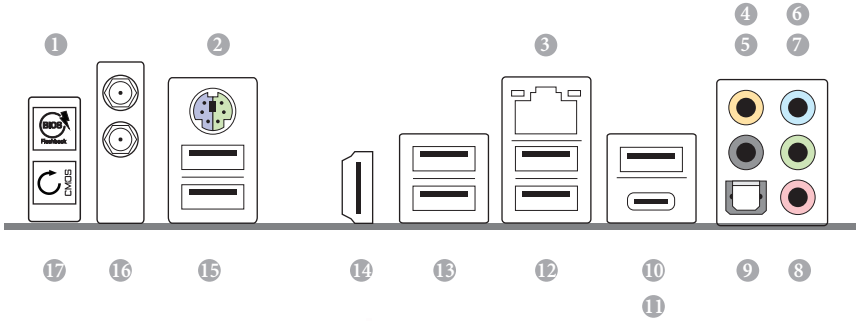

No.	Description	No.	Description
1	BIOS Flashback Button	10	USB 3.2 Gen2 Type-A Port
2	PS/2 Mouse/Keyboard Port		(USB31_TA_1)
3	2.5G LAN RJ-45 Port*	11	USB 3.2 Gen2 Type-C Port (USB31_TC_1)
4	Central / Bass (Orange)	12	USB 2.0 Ports (USB_12)**
5	Rear Speaker (Black)	13	USB 3.2 Gen1 Ports (USB3_3_4)
6	Line In (Light Blue)	14	HDMI Port
7	Front Speaker (Lime)**	15	USB 3.2 Gen1 Ports (USB3_1_2)
8	Microphone (Pink)	16	Antenna Ports
9	Optical SPDIF Out Port	17	Clear CMOS Button

* There are two LEDs on each LAN port. Please refer to the table below for the LAN port LED indications.

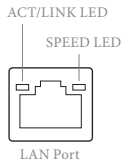

Activity / Link LED		Speed LED	
Status	Description	Status	Description
Off	No Link	Off	10Mbps connection
Blinking	Data Activity	Orange	100Mbps/1Gbps connection
On	Link	Green	2.5Gbps connection

** If you use a 2-channel speaker, please connect the speaker's plug into "Front Speaker Jack". See the table below for connection details in accordance with the type of speaker you use.

Audio Output Channels	Front Speaker (No. 7)	Rear Speaker (No.5)	Central / Bass (No. 4)	Line In (No. 6)
2	V	--	--	--
4	V	V	--	--
6	V	V	V	--
8	V	V	V	V

*** ACPI wake-up function is not supported on USB_12 ports.

1.5 WiFi-802.11ax Module and ASRock WiFi 2.4/5 GHz Antenna

WiFi-802.11ax + BT Module

This motherboard comes with an exclusive WiFi 802.11 a/b/g/n/ax + BT v5.1 module (pre-installed on the rear I/O panel) that offers support for WiFi 802.11 a/b/g/n/ax connectivity standards and Bluetooth v5.1. WiFi + BT module is an easy-to-use wireless local area network (WLAN) adapter to support WiFi + BT. Bluetooth v5.1 standard features Smart Ready technology that adds a whole new class of functionality into the mobile devices. BT 5.1 also includes Low Energy Technology and ensures extraordinary low power consumption for PCs. The 2T2R WiFi solution sets a WiFi high speed standard and offers max link rate up to 2.4Gbps.

* The transmission speed may vary according to the environment.



ASRock WiFi 2.4/5 GHz Antenna

Chapter 2 Installation

This is an ATX form factor motherboard. Before you install the motherboard, study the configuration of your chassis to ensure that the motherboard fits into it.

Pre-installation Precautions

Take note of the following precautions before you install motherboard components or change any motherboard settings.

- Make sure to unplug the power cord before installing or removing the motherboard. Failure to do so may cause physical injuries to you and damages to motherboard components.
- In order to avoid damage from static electricity to the motherboard's components, NEVER place your motherboard directly on a carpet. Also remember to use a grounded wrist strap or touch a safety grounded object before you handle the components.
- Hold components by the edges and do not touch the ICs.
- Whenever you uninstall any components, place them on a grounded anti-static pad or in the bag that comes with the components.
- When placing screws to secure the motherboard to the chassis, please do not over-tighten the screws! Doing so may damage the motherboard.

2.1 Installing the CPU



Unplug all power cables before installing the CPU.

1

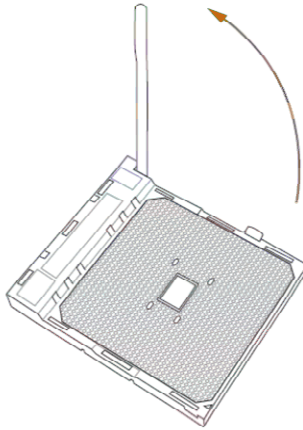

2

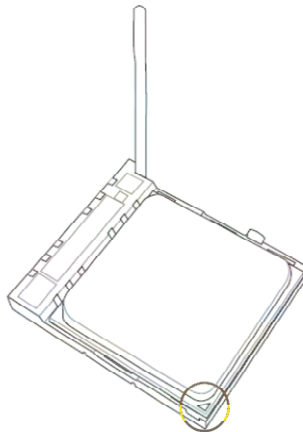

3

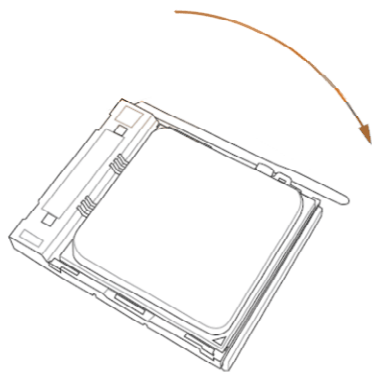

2.2 Installing the CPU Fan and Heatsink

After you install the CPU into this motherboard, it is necessary to install a larger heatsink and cooling fan to dissipate heat. You also need to spray thermal grease between the CPU and the heatsink to improve heat dissipation. Make sure that the CPU and the heatsink are securely fastened and in good contact with each other.



Please turn off the power or remove the power cord before changing a CPU or heatsink.

Installing the CPU Box Cooler SR1

1

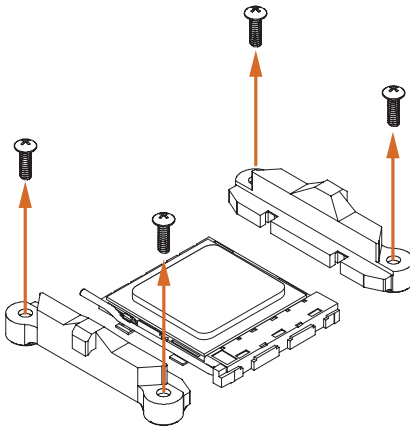

2

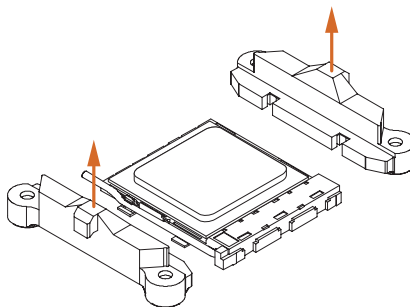

3

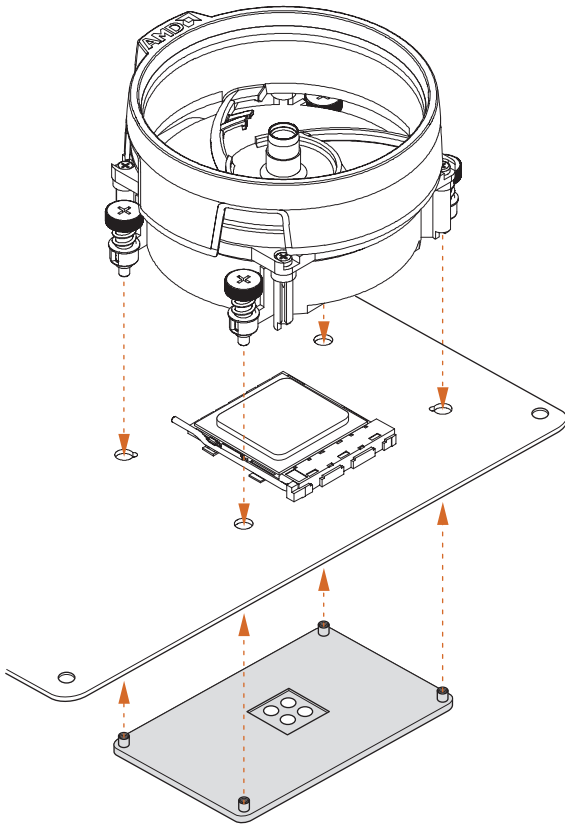

4

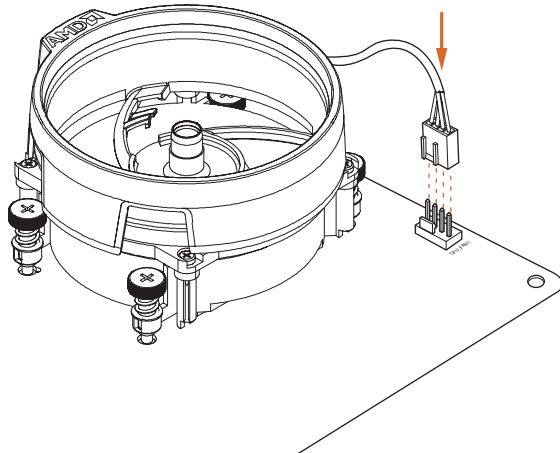

Installing the AM4 Box Cooler SR2

1

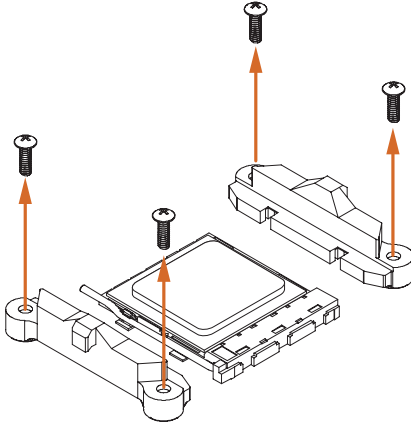

2

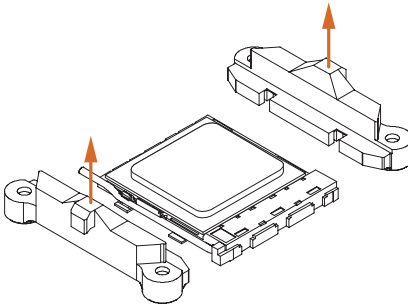

3

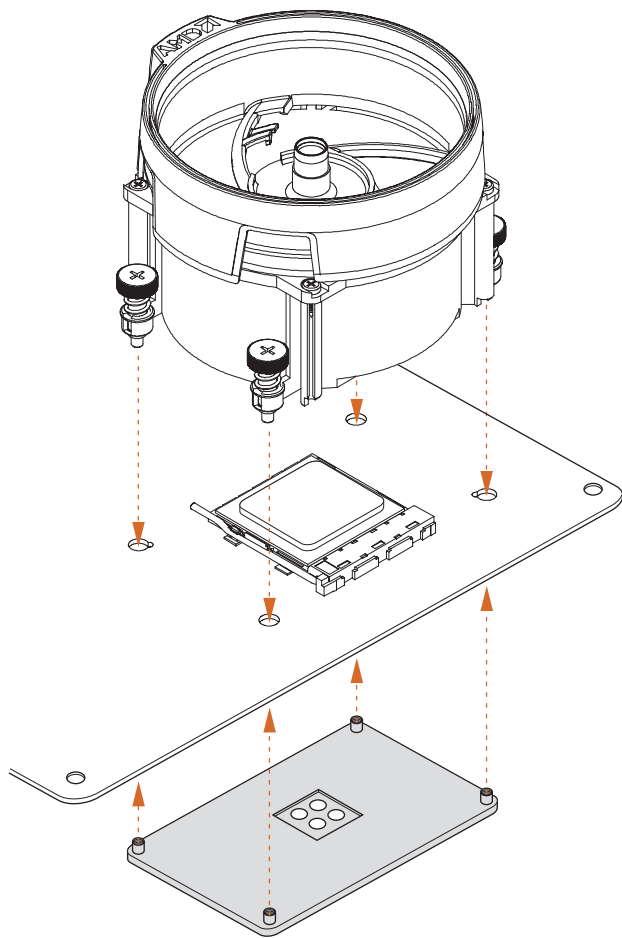

4

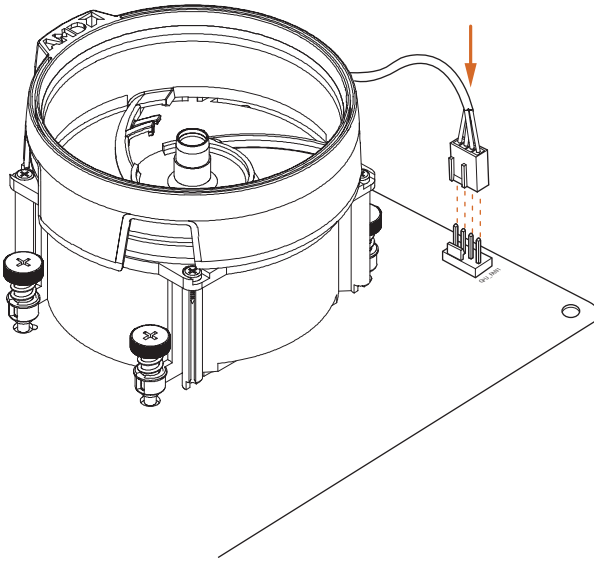

*The diagrams shown here are for reference only. The headers might be in a different position on your motherboard.

Installing the AM4 Box Cooler SR3

1

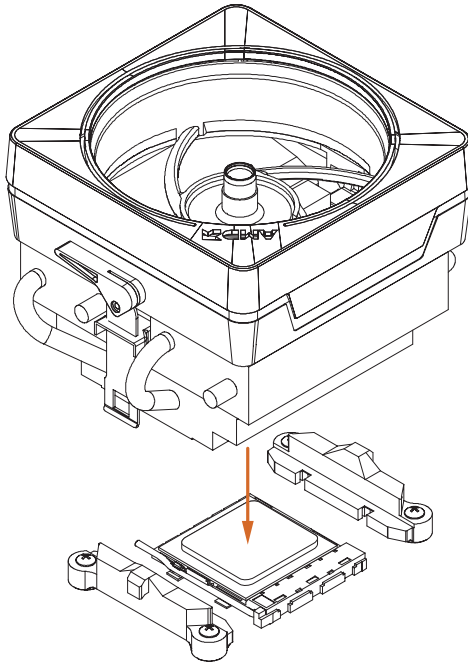

2

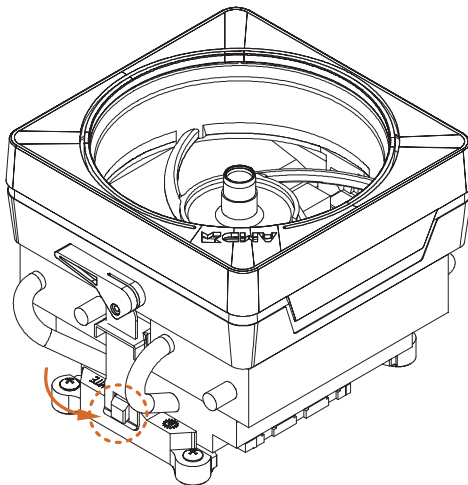

3

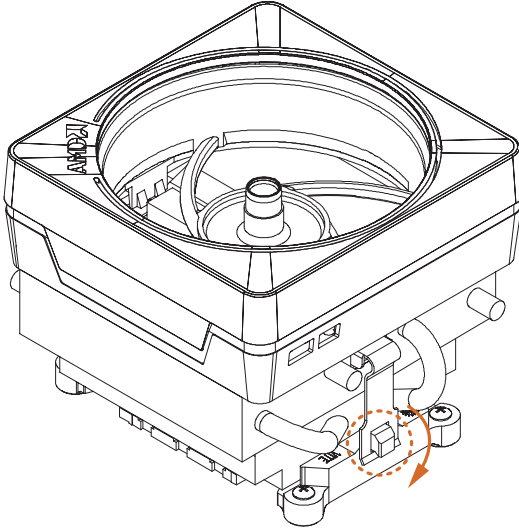

4

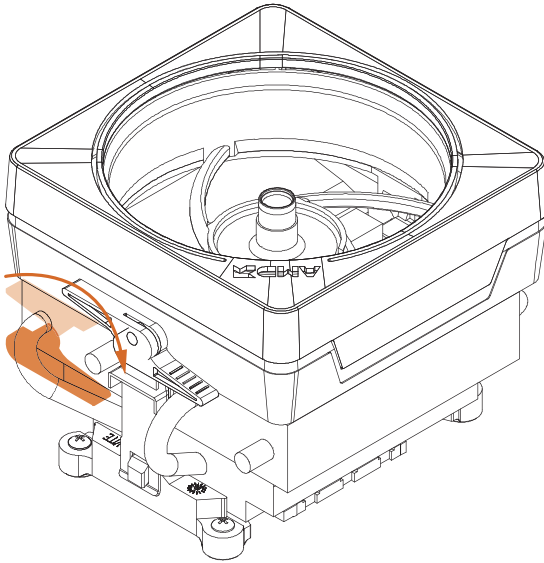

5

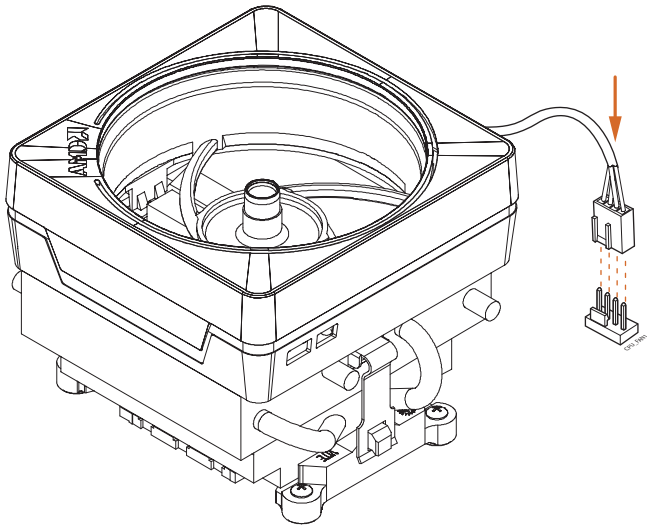

6

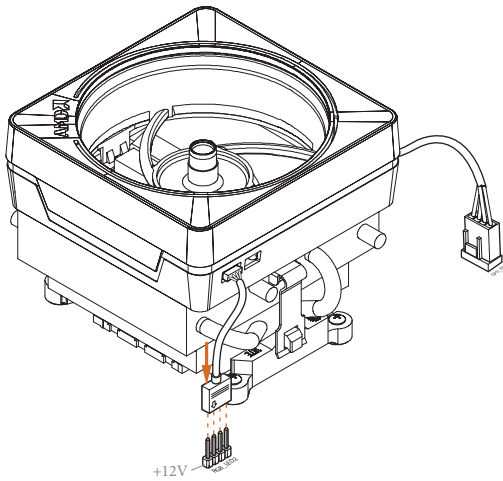

*The diagrams shown here are for reference only. The headers might be in a different position on your motherboard.

2.3 Installing Memory Modules (DIMM)

This motherboard provides four 288-pin DDR4 (Double Data Rate 4) DIMM slots, and supports Dual Channel Memory Technology.



1. For dual channel configuration, you always need to install identical (the same brand, speed, size and chip-type) DDR4 DIMM pairs.
2. It is unable to activate Dual Channel Memory Technology with only one or three memory module installed.
3. It is not allowed to install a DDR, DDR2 or DDR3 memory module into a DDR4 slot; otherwise, this motherboard and DIMM may be damaged.
4. We suggest that you install the memory modules on DDR4_A2 and DDR4_B2 first for better DRAM compatibility on 2 DIMMs configuration.

AMD non-XMP Memory Frequency Support

Ryzen Series CPUs (Vermeer):

UDIMM Memory Slot				Frequency
A1	A2	B1	B2	(Mhz)
-	SR	-	-	3200
-	DR	-	-	3200
-	SR	-	SR	3200
-	DR	-	DR	3200
SR	SR	SR	SR	2933
SR/DR	DR	SR/DR	DR	2667
SR/DR	SR/DR	SR/DR	SR/DR	2667

Ryzen Series CPUs (Matisse):

UDIMM Memory Slot				Frequency
A1	A2	B1	B2	(Mhz)
-	SR	-	-	3200
-	DR	-	-	3200
-	SR	-	SR	3200
-	DR	-	DR	3200
SR	SR	SR	SR	2933
SR/DR	DR	SR/DR	DR	2667
SR/DR	SR/DR	SR/DR	SR/DR	2667

Ryzen Series APUs (Renoir):

UDIMM Memory Slot				Frequency
A1	A2	B1	B2	(Mhz)
-	SR	-	-	3200
-	DR	-	-	3200
-	SR	-	SR	3200
-	DR	-	DR	3200
SR	SR	SR	SR	2933
SR/DR	DR	SR/DR	DR	2667
SR/DR	SR/DR	SR/DR	SR/DR	2667

Ryzen Series CPUs (Pinnacle Ridge):

UDIMM Memory Slot				Frequency
A1	A2	B1	B2	(Mhz)
-	SR	-	-	2933
-	DR	-	-	2933
-	SR	-	SR	2933
-	DR	-	DR	2933
SR	SR	SR	SR	2933
SR/DR	DR	SR/DR	DR	2667
SR/DR	SR/DR	SR/DR	SR/DR	2133-2400

Ryzen Series APUs (Picasso):

A1	UDIMM Memory Slot			Frequency (Mhz)
	A2	B1	B2	
-	SR	-	-	2933
-	DR	-	-	2667
-	SR	-	SR	2667
-	DR	-	DR	2400
SR	SR	SR	SR	2133
SR/DR	DR	SR/DR	DR	1866
SR/DR	SR/DR	SR/DR	SR/DR	1866

SR: Single rank DIMM, 1Rx4 or 1Rx8 on DIMM module label

DR: Dual rank DIMM, 2Rx4 or 2Rx8 on DIMM module label



The DIMM only fits in one correct orientation. It will cause permanent damage to the motherboard and the DIMM if you force the DIMM into the slot at incorrect orientation.

1

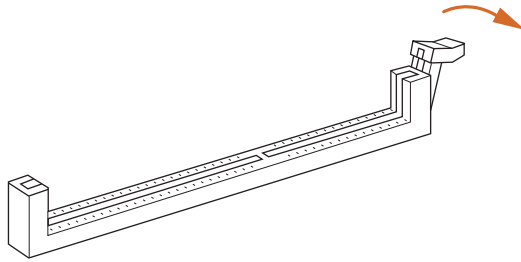

2

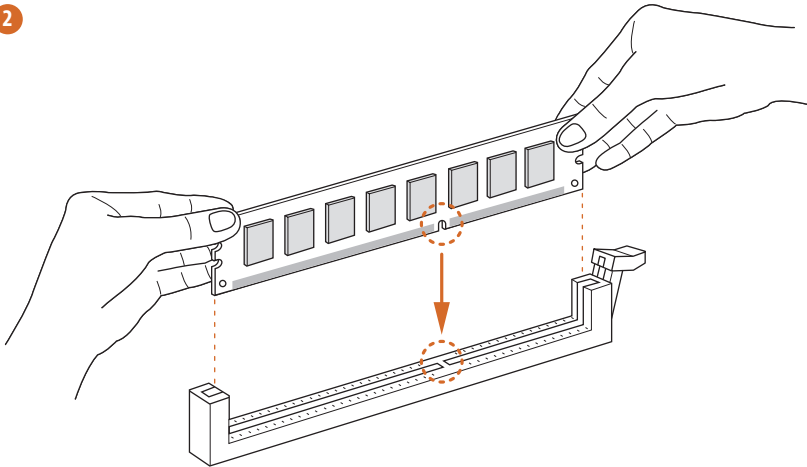

3

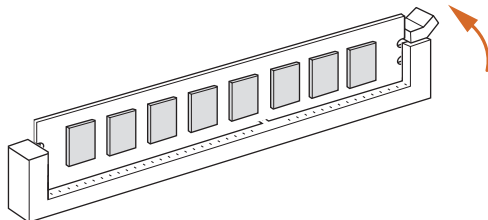

2.4 Expansion Slots (PCI Express Slots)

There are 4 PCI Express slots on the motherboard.



Before installing an expansion card, please make sure that the power supply is switched off or the power cord is unplugged. Please read the documentation of the expansion card and make necessary hardware settings for the card before you start the installation.

PCIe slots:

PCIe1 (PCIe 4.0 x16 slot) is used for PCI Express x16 lane width graphics cards.

PCIe2 (PCIe 4.0 x1 slot) is used for PCI Express x1 lane width cards.

PCIe3 (PCIe 4.0 x16 slot) is used for PCI Express x8 lane width graphics cards.

PCIe4 (PCIe 4.0 x16 slot) is used for PCI Express x4 lane width graphics cards.

* If M2_3 is occupied, PCIe4 slot will be disabled

PCIe Slot Configurations

Ryzen series CPUs (Vermeer):

	PCIe1	PCIe3	PCIe4
Single Graphics Card	Gen4x16	N/A	N/A
Two Graphics Cards in CrossFireX™ or SLI™ Mode	Gen4x8	Gen4x8	N/A
Three Graphics Cards in 3-Way CrossFireX™ Mode	Gen4x8	Gen4x8	Gen4x4

Ryzen series CPUs (Matisse):

	PCIe1	PCIe3	PCIe4
Single Graphics Card	Gen4x16	N/A	N/A
Two Graphics Cards in CrossFireX™ or SLI™ Mode	Gen4x8	Gen4x8	N/A
Three Graphics Cards in 3-Way CrossFireX™ Mode	Gen4x8	Gen4x8	Gen4x4

Ryzen series APUs (Renoir):

	PCIe1	PCIe3	PCIe4
Single Graphics Card	Gen3x16	N/A	N/A
Two Graphics Cards in CrossFireX™ or SLI™ Mode	Gen3x8	Gen3x8	N/A
Three Graphics Cards in 3-Way CrossFireX™ Mode	Gen3x8	Gen3x8	Gen4x4

Ryzen series CPUs (Pinnacle Ridge)

	PCIe1	PCIe3	PCIe4
Single Graphics Card	Gen3x16	N/A	N/A
Two Graphics Cards in CrossFireX™ or SLI™ Mode	Gen3x8	Gen3x8	N/A
Three Graphics Cards in 3-Way CrossFireX™ Mode	Gen3x8	Gen3x8	Gen4x4

Ryzen series APUs (Picasso)

	PCIe1	PCIe4
Single Graphics Card	Gen3x8	N/A
	N/A	Gen4x4



For a better thermal environment, please connect a chassis fan to the motherboard's chassis fan connector (CHA_FAN1/WP, CHA_FAN2/WP, CHA_FAN3/WP or CHA_FAN4/WP) when using multiple graphics cards.

2.5 Jumpers Setup

The illustration shows how jumpers are setup. When the jumper cap is placed on the pins, the jumper is “Short”. If no jumper cap is placed on the pins, the jumper is “Open”.



Short



Open

Clear CMOS Jumper
(CLRCMOS1)
(see p.9, No. 22)



Short: Clear CMOS
Open: Default

CLRCMOS1 allows you to clear the data in CMOS. The data in CMOS includes system setup information such as system password, date, time, and system setup parameters. To clear and reset the system parameters to default setup, please turn off the computer and unplug the power cord, then use a jumper cap to short the pins on CLRCMOS1 for 3 seconds. Please remember to remove the jumper cap after clearing the CMOS. If you need to clear the CMOS when you just finish updating the BIOS, you must boot up the system first, and then shut it down before you do the clear-CMOS action.



The Clear CMOS Button has the same function as the Clear CMOS jumper.

2.6 Onboard Headers and Connectors



Onboard headers and connectors are NOT jumpers. Do NOT place jumper caps over these headers and connectors. Placing jumper caps over the headers and connectors will cause permanent damage to the motherboard.

System Panel Header
(9-pin PANEL1)
(see p.9, No. 19)

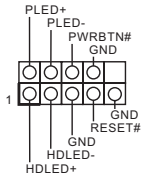

Connect the power button, reset button and system status indicator on the chassis to this header according to the pin assignments below. Note the positive and negative pins before connecting the cables.



PWRBTN (Power Button):

Connect to the power button on the chassis front panel. You may configure the way to turn off your system using the power button.

RESET (Reset Button):

Connect to the reset button on the chassis front panel. Press the reset button to restart the computer if the computer freezes and fails to perform a normal restart.

PLED (System Power LED):

Connect to the power status indicator on the chassis front panel. The LED is on when the system is operating. The LED keeps blinking when the system is in S1/S3 sleep state. The LED is off when the system is in S4 sleep state or powered off (S5).

HDLED (Hard Drive Activity LED):

Connect to the hard drive activity LED on the chassis front panel. The LED is on when the hard drive is reading or writing data.

The front panel design may differ by chassis. A front panel module mainly consists of power button, reset button, power LED, hard drive activity LED, speaker and etc. When connecting your chassis front panel module to this header, make sure the wire assignments and the pin assignments are matched correctly.

Power LED and Speaker Header
 (7-pin SPK_PLED1)
 (see p.9, No. 23)

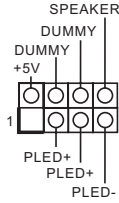

Please connect the chassis power LED and the chassis speaker to this header.

Serial ATA3 Connectors

Right Angle:

- (SATA3_1: see p.9, No. 14)(Lower)
- (SATA3_2: see p.9, No. 14)(Upper)
- (SATA3_3: see p.9, No. 15)(Lower)
- (SATA3_4: see p.9, No. 15)(Upper)
- (SATA3_5: see p.9, No. 16)(Lower)
- (SATA3_6: see p.9, No. 16)(Upper)
- (SATA3_7: see p.9, No. 17)(Lower)
- (SATA3_8: see p.9, No. 17)(Upper)

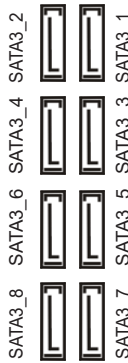

These eight SATA3 connectors support SATA data cables for internal storage devices with up to 6.0 Gb/s data transfer rate.

USB 2.0 Headers

- (9-pin USB_3_4) (see p.9, No. 25)
- (9-pin USB_5_6) (see p.9, No. 24)

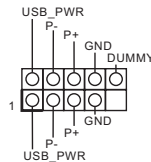

There are two headers on this motherboard. Each USB 2.0 header can support two ports.

USB 3.2 Gen1 Headers

- (19-pin USB3_7_8) (see p.9, No. 9)

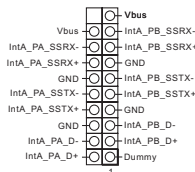

There are two headers on this motherboard. Each USB 3.2 Gen1 header can support two ports.

(19-pin USB3_5_6)
(see p.9, No. 13)

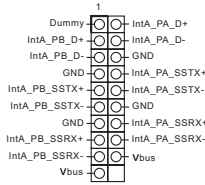

Front Panel Type C USB
3.2 Gen2 Header
(20-pin F_USB31_TC_1)
(see p.9, No. 11)

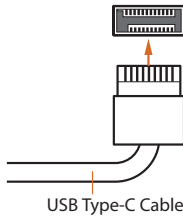

There is one Front Panel Type C USB 3.2 Gen2 Header on this motherboard. This header is used for connecting a USB 3.2 Gen2 module for additional USB 3.2 Gen2 ports.

Front Panel Audio Header
(9-pin HD_AUDIO1)
(see p.9, No. 31)

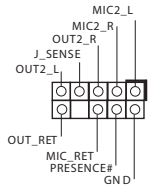

This header is for connecting audio devices to the front audio panel.



1. High Definition Audio supports Jack Sensing, but the panel wire on the chassis must support HDA to function correctly. Please follow the instructions in our manual and chassis manual to install your system.
2. If you use an AC'97 audio panel, please install it to the front panel audio header by the steps below:
 - A. Connect Mic_IN (MIC) to MIC2_L.
 - B. Connect Audio_R (RIN) to OUT2_R and Audio_L (LIN) to OUT2_L.
 - C. Connect Ground (GND) to Ground (GND).
 - D. MIC_RET and OUT_RET are for the HD audio panel only. You don't need to connect them for the AC'97 audio panel.
 - E. To activate the front mic, go to the "FrontMic" Tab in the Realtek Control panel and adjust "Recording Volume".

Chassis Water Pump Fan
Connectors
(4-pin CHA_FAN1/WP)
(see p.9, No. 10)

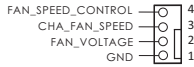

This motherboard provides four 4-Pin water cooling chassis fan connectors. If you plan to connect a 3-Pin chassis water cooler fan, please connect it to Pin 1-3.

(4-pin CHA_FAN2/WP)
(see p.9, No. 27)

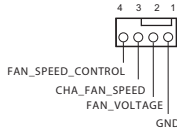

(4-pin CHA_FAN3/WP)
(see p.9, No. 33)

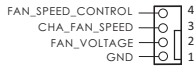

(4-pin CHA_FAN4/WP)
(see p.9, No. 26)

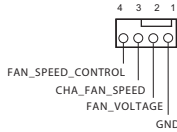

CPU Fan Connector
(4-pin CPU_FAN1)
(see p.9, No. 3)

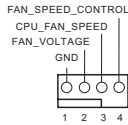

This motherboard provides a 4-Pin CPU fan (Quiet Fan) connector. If you plan to connect a 3-Pin CPU fan, please connect it to Pin 1-3.

CPU Water Pump Fan
Connector
(4-pin CPU_FAN2/
WP_3A)
(see p.9, No. 12)

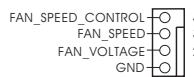

This motherboard provides a 4-Pin water cooling CPU fan connector. If you plan to connect a 3-Pin CPU water cooler fan, please connect it to Pin 1-3.

ATX Power Connector
(24-pin ATXPWR1)
(see p.9, No. 8)

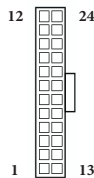

This motherboard provides a 24-pin ATX power connector. To use a 20-pin ATX power supply, please plug it along Pin 1 and Pin 13.

ATX 12V Power
Connectors
(8-pin ATX12V1)
(see p.9, No. 1)
(8-pin ATX12V2)
(see p.9, No. 2)

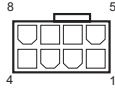

This motherboard provides two 8-pin ATX 12V power connector. To use a 4-pin ATX power supply, please plug it along Pin 1 and Pin 5.

*Connecting an ATX 12V 8-pin cable to ATX12V2 is optional.

***Warning: Please make sure that the power cable connected is for the CPU and not the graphics card. Do not plug the PCIe power cable to this connector.**

SPI TPM Header
(13-pin SPI_TPM_J1)
(see p.9, No. 32)

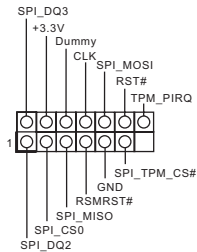

This connector supports SPI Trusted Platform Module (TPM) system, which can securely store keys, digital certificates, passwords, and data. A TPM system also helps enhance network security, protects digital identities, and ensures platform integrity.

Thunderbolt AIC
Connector
(5-pin TB1)
(see p.9, No. 28)



Please connect a Thunderbolt™ add-in card (AIC) to the Thunderbolt AIC connector via the GPIO cable.

*Please install the Thunderbolt™ AIC card to PCIe4 (default slot).

*For the further information, please visit www.asrock.com.

RGB LED Headers
(4-pin RGB_HEADER1)
(see p.9, No. 29)
(4-pin RGB_HEADER2)
(see p.9, No. 4)



These two RGB headers are used to connect RGB LED extension cable which allows users to choose from various LED lighting effects.

Caution: Never install the RGB LED cable in the wrong orientation; otherwise, the cable may be damaged.

*Please refer to page 75 for further instructions on these two headers.

Addressable LED Headers
(3-pin ADDR_LED1)
(see p.9, No. 30)
(3-pin ADDR_LED2)
(see p.9, No. 5)

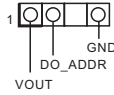

These two Addressable headers are used to connect Addressable LED extension cable which allows users to choose from various LED lighting effects.

Caution: Never install the Addressable LED cable in the wrong orientation; otherwise, the cable may be damaged.

*Please refer to page 76 for further instructions on this header.

2.7 Smart Switches

The motherboard has five smart switches: Power Button, Reset Button, Clear CMOS Buttons and BIOS Flashback Switch, allowing users to quickly turn on/off the system, reset the system, clear the CMOS values or flash the BIOS.

Power Button
(PWRBTN)
(see p.9, No. 20)



Power Button allows users to quickly turn on/off the system.

Reset Button
(RSTBTN)
(see p.9, No. 21)



Reset Button allows users to quickly reset the system.

Clear CMOS Buttons
(CLRCBTN1)
(see p.11, No. 17)



Clear CMOS Buttons allow users to quickly clear the CMOS values.

(CLRCBTN2)
(see p.9, No. 18)



This function is workable only when you power off your computer and unplug the power supply.

BIOS Flashback Button
(BIOS_FB1)
(see p.10, No. 1)



BIOS Flashback Switch allows users
to flash the BIOS.

ASRock BIOS Flashback feature allows you to update BIOS without powering on the system, even without CPU.

To use the USB BIOS Flashback function, Please follow the steps below.

1. Download the latest BIOS file from ASRock's website : <http://www.asrock.com>.
2. Copy the BIOS file to your USB flash drive. Please make sure the file system of your USB flash drive must be FAT32.
3. Extract BIOS file from the zip file.
4. Rename the file to "**creative.rom**" and save it to the root directory of X: USB flash drive.
5. Plug the 24 pin power connector to the motherboard. Then turn on the power supply's AC switch.

*There is no need to power on the system.

6. Then plug your USB drive to the USB BIOS Flashback port.
7. Press the BIOS Flashback Switch for about three seconds. Then the LED starts to blink.
8. Wait until the LED stops blinking, indicating that BIOS flashing has been completed.

*If the LED light turns solid green, this means that the BIOS Flashback is not operating properly. Please make sure that you plug the USB drive to the USB BIOS Flashback port.

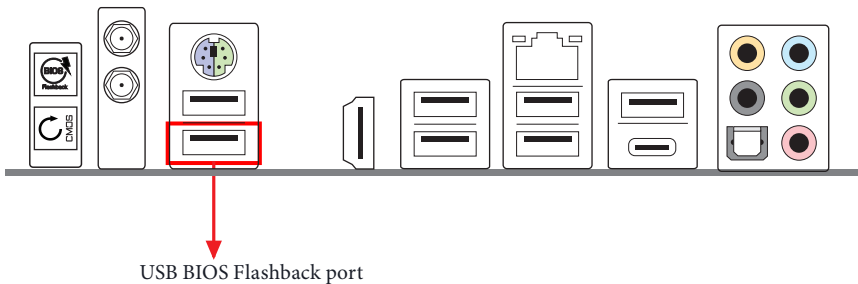

2.8 Dr. Debug

Dr. Debug is used to provide code information, which makes troubleshooting even easier. Please see the diagrams below for reading the Dr. Debug codes.

Code	Description
0x10	PEI_CORE_STARTED
0x11	PEI_CAR_CPU_INIT
0x15	PEI_CAR_NB_INIT
0x19	PEI_CAR_SB_INIT
0x31	PEI_MEMORY_INSTALLED
0x32	PEI_CPU_INIT
0x33	PEI_CPU_CACHE_INIT
0x34	PEI_CPU_AP_INIT
0x35	PEI_CPU_BSP_SELECT
0x36	PEI_CPU_SMM_INIT
0x37	PEI_MEM_NB_INIT
0x3B	PEI_MEM_SB_INIT
0x4F	PEI_DXE_IPL_STARTED
0x60	DXE_CORE_STARTED
0x61	DXE_NVRAM_INIT
0x62	DXE_SBRUN_INIT

0x63	DXE_CPU_INIT
0x68	DXE_NB_HB_INIT
0x69	DXE_NB_INIT
0x6A	DXE_NB_SMM_INIT
0x70	DXE_SB_INIT
0x71	DXE_SB_SMM_INIT
0x72	DXE_SB_DEVICES_INIT
0x78	DXE_ACPI_INIT
0x79	DXE_CSM_INIT
0x90	DXE_BDS_STARTED
0x91	DXE_BDS_CONNECT_DRIVERS
0x92	DXE_PCI_BUS_BEGIN
0x93	DXE_PCI_BUS_HPC_INIT
0x94	DXE_PCI_BUS_ENUM
0x95	DXE_PCI_BUS_REQUEST_RESOURCES
0x96	DXE_PCI_BUS_ASSIGN_RESOURCES
0x97	DXE_CON_OUT_CONNECT
0x98	DXE_CON_IN_CONNECT

0x99	DXE_SIO_INIT
0x9A	DXE_USB_BEGIN
0x9B	DXE_USB_RESET
0x9C	DXE_USB_DETECT
0x9D	DXE_USB_ENABLE
0xA0	DXE_IDE_BEGIN
0xA1	DXE_IDE_RESET
0xA2	DXE_IDE_DETECT
0xA3	DXE_IDE_ENABLE
0xA4	DXE_SCSI_BEGIN
0xA5	DXE_SCSI_RESET
0xA6	DXE_SCSI_DETECT
0xA7	DXE_SCSI_ENABLE
0xA8	DXE_SETUP_VERIFYING_PASSWORD
0xA9	DXE_SETUP_START
0xAB	DXE_SETUP_INPUT_WAIT
0xAD	DXE_READY_TO_BOOT
0xAE	DXE_LEGACY_BOOT

0xAF	DXE_EXIT_BOOT_SERVICES
0xB0	RT_SET_VIRTUAL_ADDRESS_MAP_BEGIN
0xB1	RT_SET_VIRTUAL_ADDRESS_MAP_END
0xB2	DXE_LEGACY_OPROM_INIT
0xB3	DXE_RESET_SYSTEM
0xB4	DXE_USB_HOTPLUG
0xB5	DXE_PCI_BUS_HOTPLUG
0xB6	DXE_NVRAM_CLEANUP
0xB7	DXE_CONFIGURATION_RESET
0xF0	PEI_RECOVERY_AUTO
0xF1	PEI_RECOVERY_USER
0xF2	PEI_RECOVERY_STARTED
0xF3	PEI_RECOVERY_CAPSULE_FOUND
0xF4	PEI_RECOVERY_CAPSULE_LOADED
0xE0	PEI_S3_STARTED
0xE1	PEI_S3_BOOT_SCRIPT
0xE2	PEI_S3_VIDEO_REPOST

0xE3	PEI_S3_OS_WAKE
0x50	PEI_MEMORY_INVALID_TYPE
0x53	PEI_MEMORY_NOT_DETECTED
0x55	PEI_MEMORY_NOT_INSTALLED
0x57	PEI_CPU_MISMATCH
0x58	PEI_CPU_SELF_TEST_FAILED
0x59	PEI_CPU_NO_MICROCODE
0x5A	PEI_CPU_ERROR
0x5B	PEI_RESET_NOT_AVAILABLE
0xD0	DXE_CPU_ERROR
0xD1	DXE_NB_ERROR
0xD2	DXE_SB_ERROR
0xD3	DXE_ARCH_PROTOCOL_NOT_AVAILABLE
0xD4	DXE_PCI_BUS_OUT_OF_RESOURCES
0xD5	DXE_LEGACY_OPROM_NO_SPACE
0xD6	DXE_NO_CON_OUT
0xD7	DXE_NO_CON_IN

0xD8	DXE_INVALID_PASSWORD
0xD9	DXE_BOOT_OPTION_LOAD_ERROR
0xDA	DXE_BOOT_OPTION_FAILED
0xDB	DXE_FLASH_UPDATE_FAILED
0xDC	DXE_RESET_NOT_AVAILABLE
0xE8	PEI_MEMORY_S3_RESUME_FAILED
0xE9	PEI_S3_RESUME_PPI_NOT_FOUND
0xEA	PEI_S3_BOOT_SCRIPT_ERROR
0xEB	PEI_S3_OS_WAKE_ERROR

2.9 SLI™ and Quad SLI™ Operation Guide

This motherboard supports NVIDIA® SLI™ and Quad SLI™ (Scalable Link Interface) technology that allows you to install up to two identical PCI Express x16 graphics cards.

* This feature is only supported with Ryzen Series CPUs (Vermeer, Matisse, Renoir and Pinnacle Ridge).



Requirements

1. You should only use identical SLI™-ready graphics cards that are NVIDIA® certified.
2. Make sure that your graphics card driver supports NVIDIA® SLI™ technology. Download the drivers from the NVIDIA® website: www.nvidia.com
3. Make sure that your power supply unit (PSU) can provide at least the minimum power your system requires. It is recommended to use a NVIDIA® certified PSU. Please refer to the NVIDIA® website for details.

2.9.1 Installing Two SLI™-Ready Graphics Cards

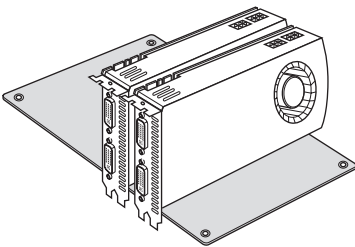

Step 1

Insert one graphics card into PCIE1 slot and the other graphics card to PCIE3 slot. Make sure that the cards are properly seated on the slots.

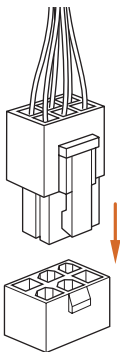

Step 2

If required, connect the auxiliary power source to the PCI Express graphics cards.

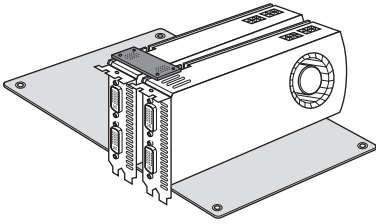

Step 3

Align and insert the SLI Bridge Card to the goldfingers on each graphics card. Make sure the SLI Bridge Card is firmly in place.



SLI Bridge Card

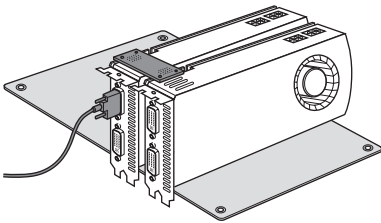

Step 4

Connect a VGA/DVI/DP/HDMI cable from the monitor to the corresponding port on the graphics card installed to the PCIE1 slot.

2.9.2 Driver Installation and Setup

Install the graphics card drivers to your system. After that, you can enable the Multi-Graphics Processing Unit (GPU) in the NVIDIA® nView system tray utility. Please follow the below procedures to enable the multi-GPU.

For SLI™ and Quad SLI™ mode



Step 1

Double-click the **NVIDIA Control Panel** icon in the Windows® system tray.

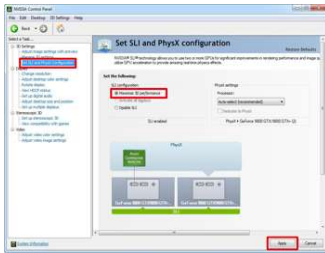

Step 2

In the left pane, click **Set SLI and PhysX configuration**. Then select **Maximize 3D performance** and click **Apply**.

Step 3

Reboot your system.

Step 4

You can freely enjoy the benefits of SLI™ or Quad SLI™.

2.10 CrossFireX™, 3-Way CrossFireX™ and Quad CrossFireX™ Operation Guide

This motherboard supports CrossFireX™, 3-way CrossFireX™ and Quad CrossFireX™ that allows you to install up to three identical PCI Express x16 graphics cards.

* 3-Way CrossFireX™ is only supported with Ryzen Series CPUs (Vermeer, Matisse, Renoir and Pinnacle Ridge).



1. You should only use identical CrossFireX™-ready graphics cards that are AMD certified.
2. Make sure that your graphics card driver supports AMD CrossFireX™ technology. Download the drivers from the AMD's website: www.amd.com
3. Make sure that your power supply unit (PSU) can provide at least the minimum power your system requires. It is recommended to use a AMD certified PSU. Please refer to the AMD's website for details.
4. If you pair a 12-pipe CrossFireX™ Edition card with a 16-pipe card, both cards will operate as 12-pipe cards while in CrossFireX™ mode.
5. Different CrossFireX™ cards may require different methods to enable CrossFireX™. Please refer to AMD graphics card manuals for detailed installation guide.

2.10.1 Installing Two CrossFireX™-Ready Graphics Cards

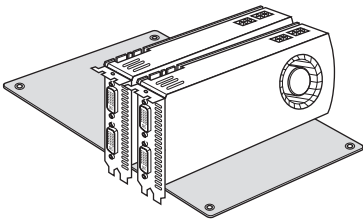

Step 1

Insert one graphics card into PCI E1 slot and the other graphics card to PCI E3 slot. Make sure that the cards are properly seated on the slots.



CrossFire Bridge

Step 2

Connect two graphics cards by installing a CrossFire Bridge on the CrossFire Bridge Interconnects on the top of the graphics cards. (The CrossFire Bridge is provided with the graphics card you purchase, not bundled with this motherboard. Please refer to your graphics card vendor for details.)

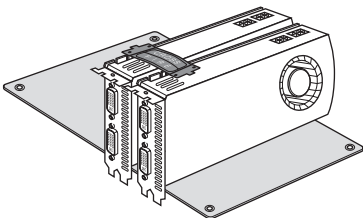

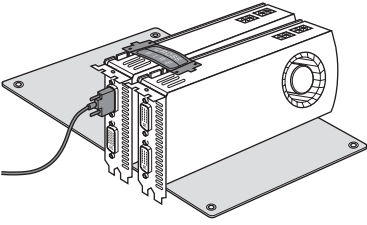
**Step 3**

Connect a VGA/DVI/DP/HDMI cable from the monitor to the corresponding port on the graphics card installed to the PCIe1 slot.

2.10.2 Installing Three CrossFireX™-Ready Graphics Cards

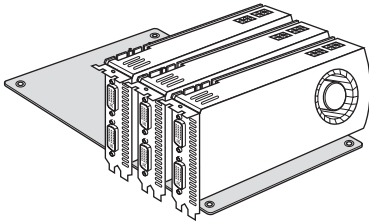

Step 1

Insert one graphics card into PCI E1 slot, another graphics card to PCI E3 slot, and the other graphics card to PCI E4 slot. Make sure that the cards are properly seated on the slots.



CrossFire Bridge

Step 2

Use one CrossFire Bridge to connect the graphics cards on PCI E1 and PCI E3 slots, and use the other CrossFire Bridge to connect the graphics cards on PCI E3 and PCI E4 slots. (The CrossFire Bridge is provided with the graphics card you purchase, not bundled with this motherboard. Please refer to your graphics card vendor for details.)

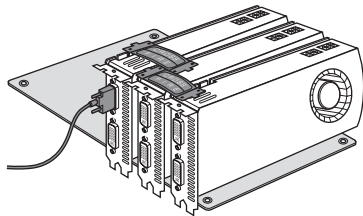
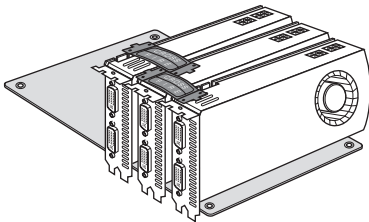

Step 3

Connect a VGA/DVI/DP/HDMI cable from the monitor to the corresponding port on the graphics card installed to the PCI E1 slot.

2.10.3 Driver Installation and Setup

Step 1

Power on your computer and boot into OS.

Step 2

Remove the AMD drivers if you have any VGA drivers installed in your system.



The Catalyst Uninstaller is an optional download. We recommend using this utility to uninstall any previously installed Catalyst drivers prior to installation. Please check AMD's website for AMD driver updates.

Step 3

Install the required drivers and CATALYST Control Center then restart your computer. Please check AMD's website for details.



AMD Catalyst Control Center

Step 4

Double-click the **AMD Catalyst Control Center** icon in the Windows® system tray.



Step 5

In the left pane, click **Performance** and then **AMD CrossFireX™**. Then select **Enable AMD CrossFireX** and click **Apply**. Select the GPU number according to your graphics card and click **Apply**.

2.11 M.2_SSD (NGFF) Module Installation Guide (M2_1)

The M.2, also known as the Next Generation Form Factor (NGFF), is a small size and versatile card edge connector that aims to replace mPCIe and mSATA. The Hyper M.2 Socket (M2_1) supports SATA3 6.0 Gb/s module and M.2 PCI Express module up to Gen4x4 (64 Gb/s) (with Vermeer and Matisse) or Gen3x4 (32 Gb/s) (with Renoir, Pinnacle Ridge and Picasso).

Installing the M.2_SSD (NGFF) Module

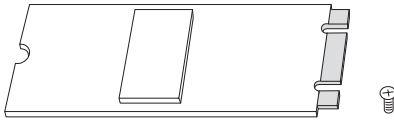

Step 1

Prepare a M.2_SSD (NGFF) module and the screw.

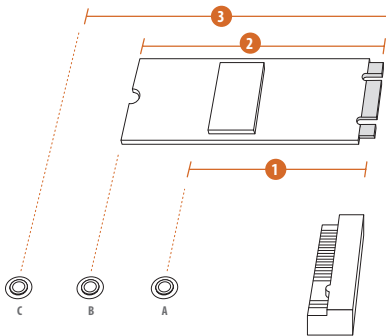

Step 2

Depending on the PCB type and length of your M.2_SSD (NGFF) module, find the corresponding nut location to be used.

No.	1	2	3
Nut Location	A	B	C
PCB Length	4.2cm	6cm	8cm
Module Type	Type 2242	Type2260	Type 2280

Step 3

Before installing a M.2 (NGFF) SSD module, please loosen the screws to remove the M.2 heatsink.

*Please remove the protective films on the bottom side of the M.2 heatsink before you install a M.2 SSD module.

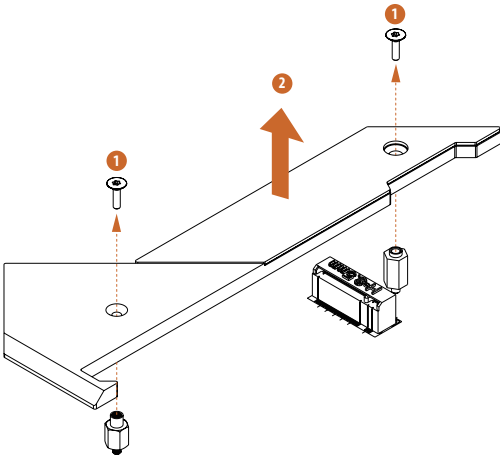
**Step 4**

Prepare the M.2 standoff that comes with the package. Then hand tighten the standoff into the desired nut location on the motherboard. Align and gently insert the M.2 (NGFF) SSD module into the M.2 slot. Please be aware that the M.2 (NGFF) SSD module only fits in one orientation.

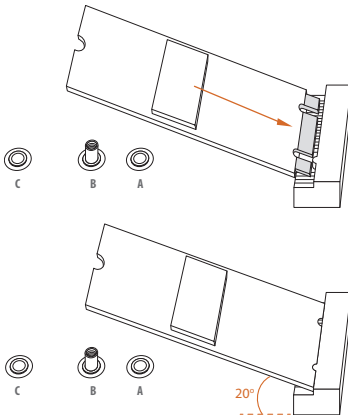
**Step 5**

Tighten the screw with a screwdriver to secure the module into place. Please do not overtighten the screw as this might damage the module.

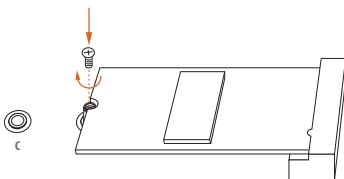

M.2_SSD (NGFF) Module Support List

Vendor	Interface	P/N
SanDisk	PCIe	SanDisk-SD6PP4M-128G(Gen2 x2)
Intel	PCIe	INTEL 6000P-SSDPEKKF256G7 (nvme)
Intel	PCIe	INTEL 6000P-SSDPEKKF512G7 (nvme)
Intel	PCIe	SSDPEKKF512G7 NVME / 512GB
Intel	SATA	540S-SSDSCKKW240H6 / 240GB
Kingston	PCIe	Kingston SHPM2280P2 / 240G (Gen2 x4)
Samsung	PCIe	Samsung XP941-MZHPU512HCGL(Gen2x4)
Samsung	PCIe	SM951 (NVME) / 512GB
Samsung	PCIe	SM951 (MZHPV512HDGL) / 512GB
ADATA	SATA	ADATA - AXNS381E-128GM-B
ADATA	PCIe	ASX8000NP-512GM-C / 512GB
ADATA	PCIe	ASX7000NP-512GT-C / 512GB
ADATA	SATA	ASU800NS38-512GT-C / 512GB
Crucial	SATA	Crucial-CT240M500SSD4-240GB
ezlink	SATA	ezlink P51B-80-120GB
Intel	SATA	INTEL 540S-SSDSCKKW240H6-240GB
Kingston	SATA	Kingston SM2280S3G2/120G - Win8.1
Kingston	SATA	Kingston-RBU-SNS8400S3 / 180GD
Kingston	PCIe	SKC1000/480G
Kingston	PCIe	SKC1000/960GB NVME
LITEON	SATA	LITEON LJH-256V2G-256GB (2260)
PLEXTOR	SATA	PLEXTOR PX-128M6G-2260-128GB
PLEXTOR	SATA	PLEXTOR PX-128M7VG-128GB
PLEXTOR	PCIe	PX-512M8PeG/ 512GB
SanDisk	SATA	SanDisk X400-SD8SN8U-128G
SanDisk	SATA	Sandisk Z400s-SD8SNAT-128G-1122
SanDisk	SATA	SanDisk-SD6SN1M-128G
Transcend	SATA	Transcend TS256GMTS800-256GB
Transcend	SATA	TS512GMTS800 / 512GB
V-Color	SATA	V-Color 120G
V-Color	SATA	V-Color 240G
WD	SATA	WD GREEN WDS240G1G0B-00RC30
WD	PCIe	WDS512G1X0C-00ENX0 (NVME) / 512GB

For the latest updates of M.2_SSD (NFGG) module support list, please visit our website for details: <http://www.asrock.com>

2.12 M.2_SSD (NGFF) Module Installation Guide (M2_2)

The M.2, also known as the Next Generation Form Factor (NGFF), is a small size and versatile card edge connector that aims to replace mPCIe and mSATA. The Hyper M.2 Socket (M2_2) supports M.2 PCI Express module up to Gen4x4 (64 Gb/s).

Installing the M.2_SSD (NGFF) Module

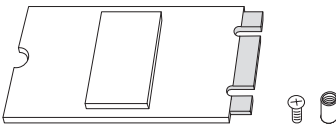

Step 1

This motherboard supports M.2_SSD (NGFF) module type 2260 and 2280 only. Prepare a proper PCB length of module, the screw and the standoff.

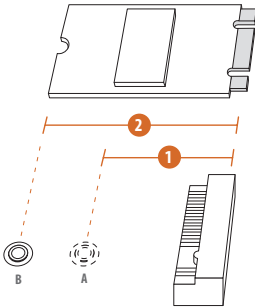

Step 2

Depending on the PCB type and length of your M.2_SSD (NGFF) module, find the corresponding nut location to be used.

No.	1	2
Nut Location	A	B
PCB Length	6cm	8cm
Module Type	Type2260	Type 2280

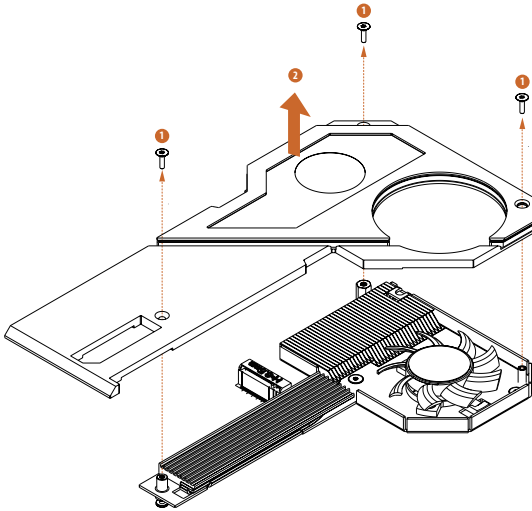

Step 3

Before installing a M.2 (NGFF) SSD module, please loosen the screws to remove the M.2 heatsink.

*Please remove the protective films on the bottom side of the M.2 heatsink before you install a M.2 SSD module.

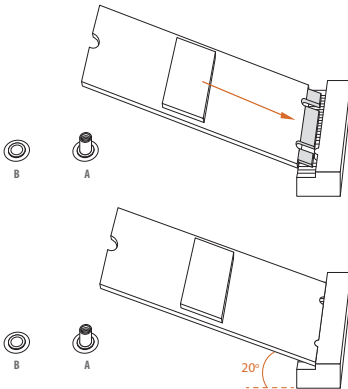

Step 4

Prepare the M.2 standoff that comes with the package. Then hand tighten the standoff into the desired nut location on the motherboard. Align and gently insert the M.2 (NGFF) SSD module into the M.2 slot. Please be aware that the M.2 (NGFF) SSD module only fits in one orientation.

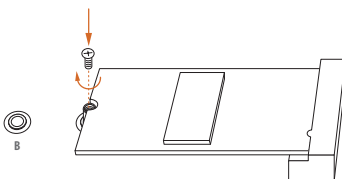

Step 5

Tighten the screw with a screwdriver to secure the module into place. Please do not overtighten the screw as this might damage the module.

M.2_SSD (NGFF) Module Support List

Vendor	Interface	P/N
SanDisk	PCIe	SanDisk-SD6PP4M-128G(Gen2 x2)
Intel	PCIe	INTEL 6000P-SSDPEKKF256G7 (nvme)
Intel	PCIe	INTEL 6000P-SSDPEKKF512G7 (nvme)
Intel	PCIe	SSDPEKKF512G7 NVME / 512GB
Kingston	PCIe	Kingston SHPM2280P2 / 240G (Gen2 x4)
Samsung	PCIe	Samsung XP941-MZHPU512HCGL(Gen2x4)
Samsung	PCIe	SM951 (NVME) / 512GB
Samsung	PCIe	SM951 (MZHPV512HDGL) / 512GB
ADATA	PCIe	ASX8000NP-512GM-C / 512GB
ADATA	PCIe	ASX7000NP-512GT-C / 512GB
Kingston	PCIe	SKC1000/480G
Kingston	PCIe	SKC1000/960GB NVME
PLEXTOR	PCIe	PX-512M8PeG/ 512GB
WD	PCIe	WDS512G1X0C-00ENX0 (NVME) / 512GB

For the latest updates of M.2_SSD (NFGG) module support list, please visit our website for details: <http://www.asrock.com>

2.13 M.2_SSD (NGFF) Module Installation Guide (M2_3)

The M.2, also known as the Next Generation Form Factor (NGFF), is a small size and versatile card edge connector that aims to replace mPCIe and mSATA. The Hyper M.2 Socket (M2_3) supports M.2 SATA3 6.0 Gb/s module and M.2 PCI Express module up to Gen4x4 (64 Gb/s).

* If M2_3 is occupied, PCIE4 slot will be disabled.

Installing the M.2_SSD (NGFF) Module

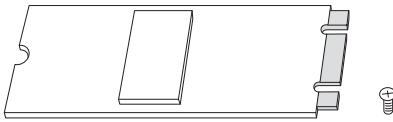

Step 1

Prepare a M.2_SSD (NGFF) module and the screw.

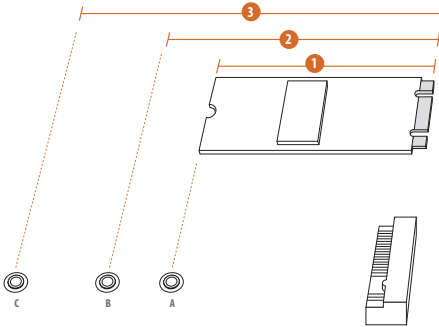

Step 2

Depending on the PCB type and length of your M.2_SSD (NGFF) module, find the corresponding nut location to be used.

No.	1	2	3
Nut Location	A	B	C
PCB Length	6cm	8cm	11cm
Module Type	Type2260	Type 2280	Type 22110

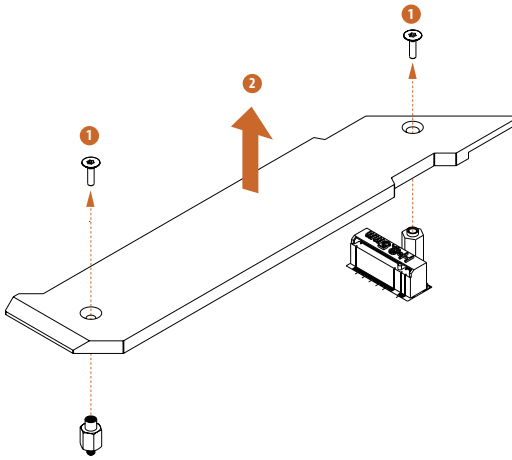
**Step 3**

Before installing a M.2 (NGFF) SSD module, please loosen the screws to remove the M.2 heatsink.

*Please remove the protective films on the bottom side of the M.2 heatsink before you install a M.2 SSD module.

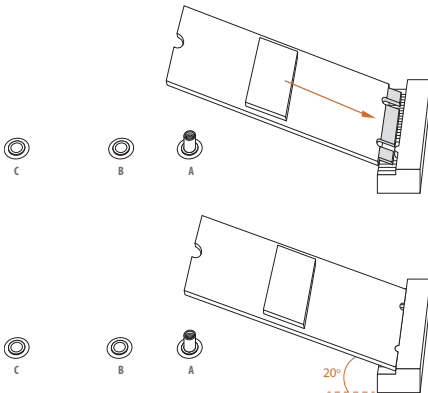
**Step 4**

Prepare the M.2 standoff that comes with the package. Then hand tighten the standoff into the desired nut location on the motherboard. Align and gently insert the M.2 (NGFF) SSD module into the M.2 slot. Please be aware that the M.2 (NGFF) SSD module only fits in one orientation.

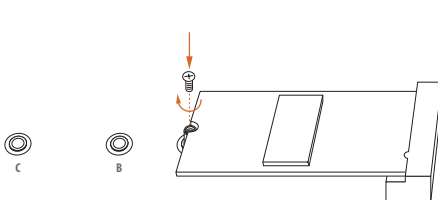
**Step 5**

Tighten the screw with a screwdriver to secure the module into place. Please do not overtighten the screw as this might damage the module.

M.2_SSD (NGFF) Module Support List

Vendor	Interface	P/N
SanDisk	PCIe	SanDisk-SD6PP4M-128G(Gen2 x2)
Intel	PCIe	INTEL 6000P-SSDPEKKF256G7 (nvme)
Intel	PCIe	INTEL 6000P-SSDPEKKF512G7 (nvme)
Intel	PCIe	SSDPEKKF512G7 NVME / 512GB
Intel	SATA	540S-SSDSCKKW240H6 / 240GB
Kingston	PCIe	Kingston SHPM2280P2 / 240G (Gen2 x4)
Samsung	PCIe	Samsung XP941-MZHPU512HCGL(Gen2x4)
Samsung	PCIe	SM951 (NVME) / 512GB
Samsung	PCIe	SM951 (MZHPU512HDGL) / 512GB
ADATA	SATA	ADATA - AXNS381E-128GM-B
ADATA	PCIe	ASX8000NP-512GM-C / 512GB
ADATA	PCIe	ASX7000NP-512GT-C / 512GB
ADATA	SATA	ASU800NS38-512GT-C / 512GB
Crucial	SATA	Crucial-CT240M500SSD4-240GB
ezlink	SATA	ezlink P51B-80-120GB
Intel	SATA	INTEL 540S-SSDSCKKW240H6-240GB
Kingston	SATA	Kingston SM2280S3G2/120G - Win8.1
Kingston	SATA	Kingston-RBU-SNS8400S3 / 180GD
Kingston	PCIe	SKC1000/480G
Kingston	PCIe	SKC1000/960GB NVME
LITEON	SATA	LITEON LJH-256V2G-256GB (2260)
PLEXTOR	SATA	PLEXTOR PX-128M6G-2260-128GB
PLEXTOR	SATA	PLEXTOR PX-128M7VG-128GB
PLEXTOR	PCIe	PX-512M8PeG/ 512GB
SanDisk	SATA	SanDisk X400-SD8SN8U-128G
SanDisk	SATA	Sandisk Z400s-SD8SNAT-128G-1122
SanDisk	SATA	SanDisk-SD6SN1M-128G
Transcend	SATA	Transcend TS256GMTS800-256GB
Transcend	SATA	TS512GMTS800 / 512GB
V-Color	SATA	V-Color 120G
V-Color	SATA	V-Color 240G
WD	SATA	WD GREEN WDS240G1G0B-00RC30
WD	PCIe	WDS512G1X0C-00ENX0 (NVME) / 512GB

For the latest updates of M.2_SSD (NFGG) module support list, please visit our website for details: <http://www.asrock.com>

Chapter 3 Software and Utilities Operation

3.1 Installing Drivers

The Support CD that comes with the motherboard contains necessary drivers and useful utilities that enhance the motherboard's features.

Running The Support CD

To begin using the support CD, insert the CD into your CD-ROM drive. The CD automatically displays the Main Menu if "AUTORUN" is enabled in your computer. If the Main Menu does not appear automatically, locate and double click on the file "ASRSETUP.EXE" in the Support CD to display the menu.

Drivers Menu

The drivers compatible to your system will be auto-detected and listed on the support CD driver page. Please click **Install All** or follow the order from top to bottom to install those required drivers. Therefore, the drivers you install can work properly.

Utilities Menu

The Utilities Menu shows the application software that the motherboard supports. Click on a specific item then follow the installation wizard to install it.

3.2 ASRock Motherboard Utility (A-Tuning)

ASRock Motherboard Utility (A-Tuning) is ASRock's multi purpose software suite with a new interface, more new features and improved utilities.

3.2.1 Installing ASRock Motherboard Utility (A-Tuning)

ASRock Motherboard Utility (A-Tuning) can be downloaded from ASRock Live Update & APP Shop. After the installation, you will find the icon "ASRock Motherboard Utility (A-Tuning)" on your desktop. Double-click the "ASRock Motherboard Utility (A-Tuning)" icon, ASRock Motherboard Utility (A-Tuning) main menu will pop up.

3.2.2 Using ASRock Motherboard Utility (A-Tuning)

There are five sections in ASRock Motherboard Utility (A-Tuning) main menu: Operation Mode, OC Tweaker, System Info, FAN-Tastic Tuning and Settings.

Operation Mode

Choose an operation mode for your computer.

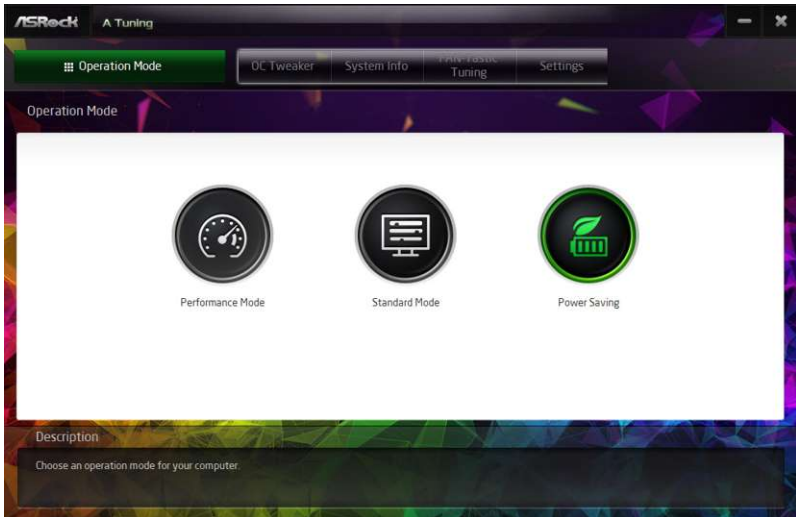

OC Tweaker

Configurations for overclocking the system.

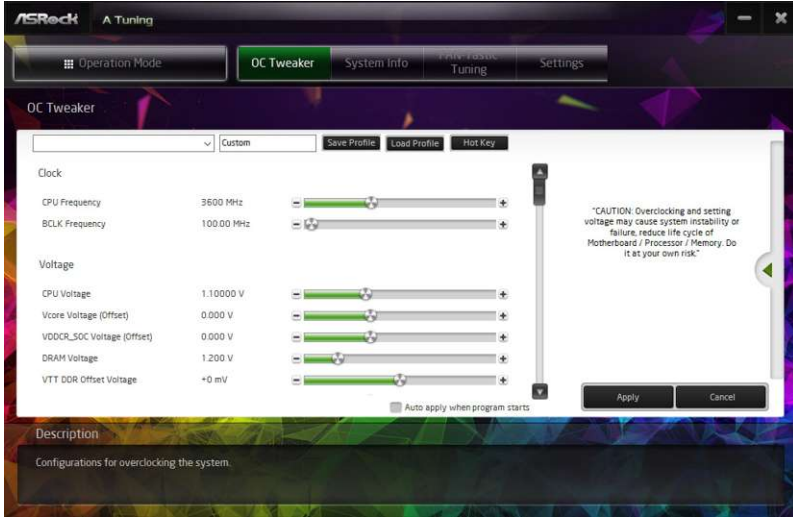

System Info

View information about the system.

*The System Browser tab may not appear for certain models.

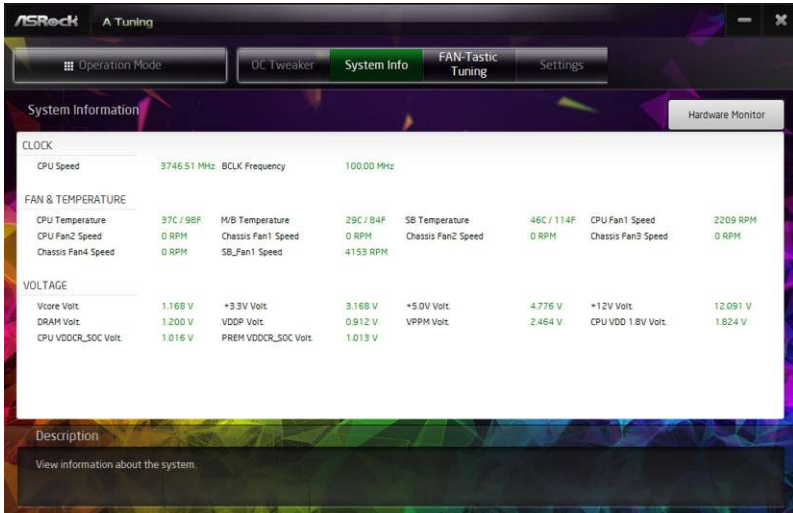

FAN-Tastic Tuning

Configure up to five different fan speeds using the graph. The fans will automatically shift to the next speed level when the assigned temperature is met.



Settings

Configure ASRock ASRock Motherboard Utility (A-Tuning). Click to select "Auto run at Windows Startup" if you want ASRock Motherboard Utility (A-Tuning) to be launched when you start up the Windows operating system.

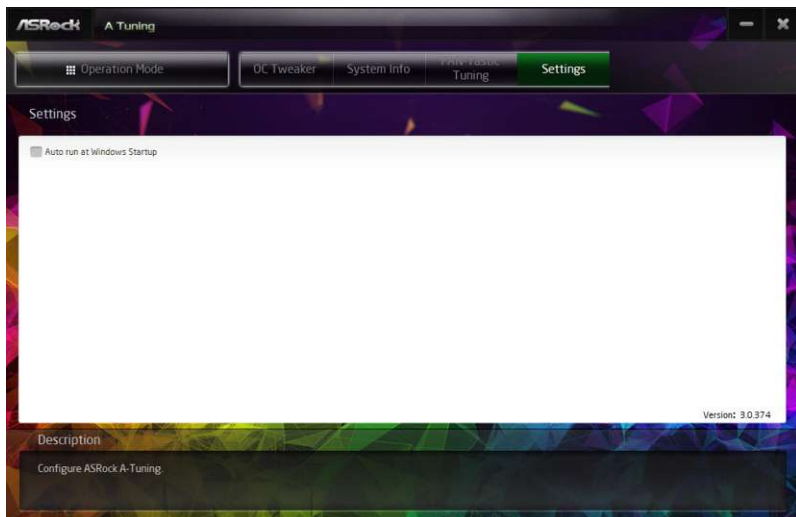

3.3 ASRock Live Update & APP Shop

The ASRock Live Update & APP Shop is an online store for purchasing and downloading software applications for your ASRock computer. You can quickly and easily install various apps and support utilities. With ASRock Live Update & APP Shop, you can optimize your system and keep your motherboard up to date simply with a few clicks.

Double-click  on your desktop to access ASRock Live Update & APP Shop utility.

**You need to be connected to the Internet to download apps from the ASRock Live Update & APP Shop.*

3.3.1 UI Overview

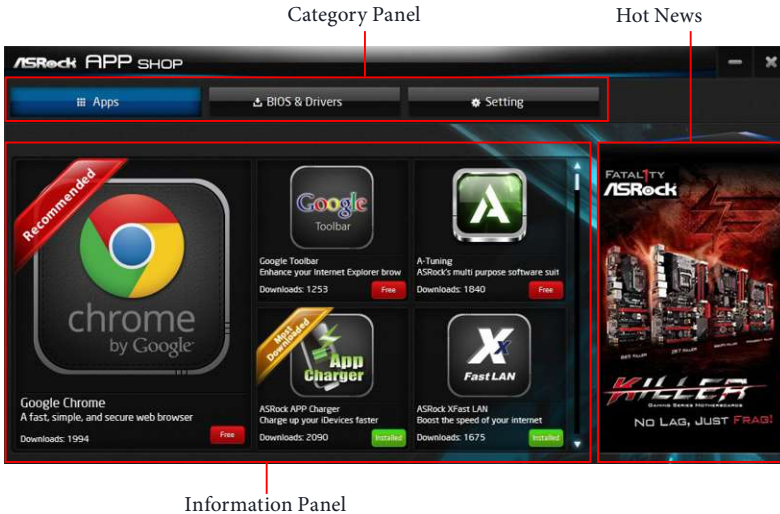

Category Panel: The category panel contains several category tabs or buttons that when selected the information panel below displays the relative information.

Information Panel: The information panel in the center displays data about the currently selected category and allows users to perform job-related tasks.

Hot News: The hot news section displays the various latest news. Click on the image to visit the website of the selected news and know more.

3.3.2 Apps

When the "Apps" tab is selected, you will see all the available apps on screen for you to download.

Installing an App

Step 1

Find the app you want to install.



The most recommended app appears on the left side of the screen. The other various apps are shown on the right. Please scroll up and down to see more apps listed.

You can check the price of the app and whether you have already installed it or not.

Free - The red icon displays the price or "Free" if the app is free of charge.

Installed - The green "Installed" icon means the app is installed on your computer.

Step 2

Click on the app icon to see more details about the selected app.

Step 3

If you want to install the app, click on the red icon  to start downloading.

**Step 4**

When installation completes, you can find the green "Installed" icon appears on the upper right corner.



To uninstall it, simply click on the trash can icon .
*The trash icon may not appear for certain apps.

Upgrading an App

You can only upgrade the apps you have already installed. When there is an available new version for your app, you will find the mark of "New Version"  appears below the installed app icon.



Step 1

Click on the app icon to see more details.

Step 2

Click on the yellow icon  to start upgrading.

3.3.3 BIOS & Drivers

Installing BIOS or Drivers

When the "BIOS & Drivers" tab is selected, you will see a list of recommended or critical updates for the BIOS or drivers. Please update them all soon.

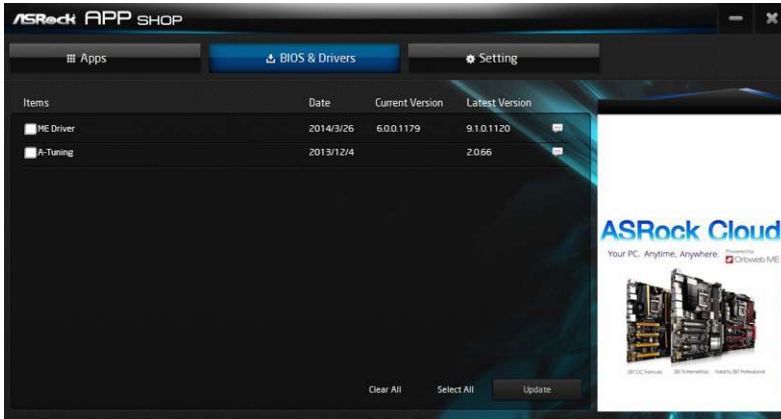

Step 1

Please check the item information before update. Click on  to see more details.

Step 2

Click to select one or more items you want to update.

Step 3

Click Update to start the update process.

3.3.4 Setting

In the "Setting" page, you can change the language, select the server location, and determine if you want to automatically run the ASRock Live Update & APP Shop on Windows startup.

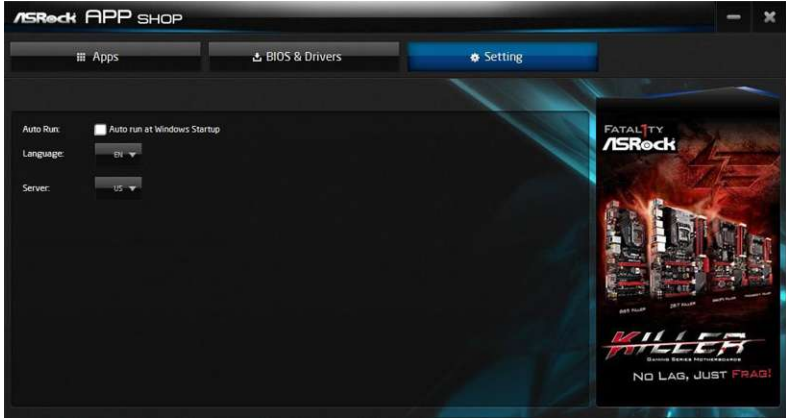

3.4 Nahimic Audio

Nahimic audio software provides an incredible high definition sound technology which boosts the audio and voice performance of your system. Nahimic Audio interface is composed of four tabs: Audio, Microphone, Sound Tracker and Settings.



There are four functions in Nahimic audio :

No.	Function	Description
1	Audio	From this tab, you can mute the current audio device, choose between four factory audio profiles, turn all audio effects on/off, restores the current profile to its default settings and access Surround Sound and various features.
2	Microphone	From this tab, you can mute the current mic device, choose between two factory mic profiles, turn/off all microphone effects, restore the current profile to its default settings, and access Static Noise Suppression and various features.
3	Sound Tracker	The Sound Tracker provides a visual indication localizing the sources of the sounds while in a game. These are represented by dynamic segments pointing the direction of the sounds: the more opaque they are, the stronger the sounds are.
4	Settings	From this tab, you can access all settings and information of the software.

3.5 Razer Synapse 3

RAZER CHROMA

Razer Synapse 3 allows you to customize the lighting on your motherboard and other Addressable RGB (ARGB) devices connected to the motherboard's headers. To set up, follow these steps:

1. Plug your ARGB LED strips or devices to any of the 3-pin 5V ARGB headers on the motherboard.
2. Download Razer Synapse 3 from razer.com/synapse then install and login.
3. Use Razer Synapse 3 to access in-depth lighting customization options; and integrate games and applications across your ARGB and Razer Chroma-enabled devices for a truly immersive experience.

Connecting the LED Strip

Connect your RGB LED strips to the **RGB LED Headers (RGB_HEADER1, RGB_HEADER12)** on the motherboard.

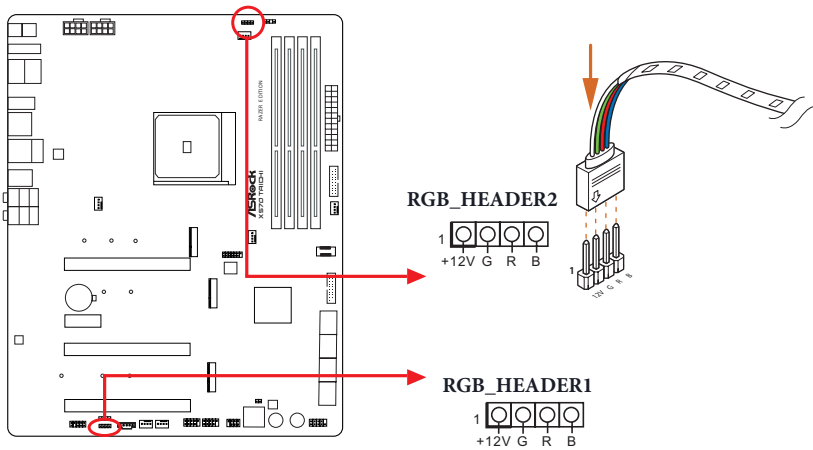

1. Never install the RGB LED cable in the wrong orientation; otherwise, the cable may be damaged.
2. Before installing or removing your RGB LED cable, please power off your system and unplug the power cord from the power supply. Failure to do so may cause damages to motherboard components.



1. Please note that the RGB LED strips do not come with the package.
2. The RGB LED header supports standard 5050 RGB LED strip (12V/G/R/B), with a maximum power rating of 3A (12V) and length within 2 meters.

Connecting the Addressable RGB LED Strip

Connect your Addressable RGB LED strips to the **Addressable LED Headers (ADDR_LED1, ADDR_LED2)** on the motherboard.

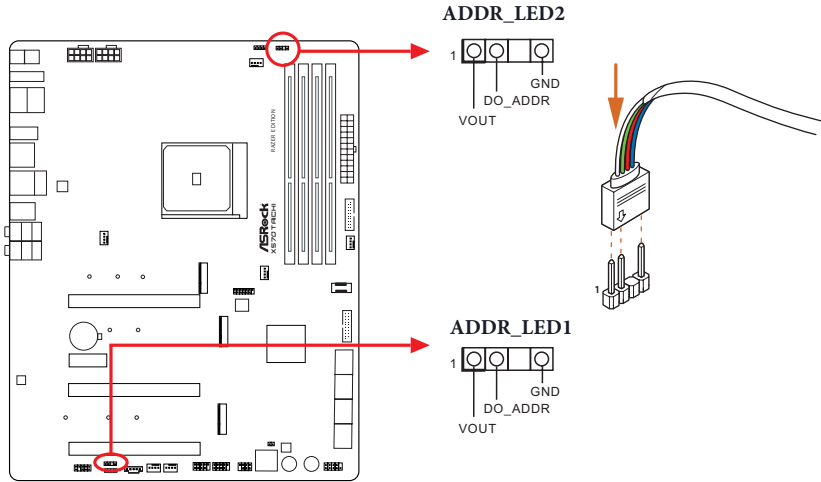

1. Never install the RGB LED cable in the wrong orientation; otherwise, the cable may be damaged.
2. Before installing or removing your RGB LED cable, please power off your system and unplug the power cord from the power supply. Failure to do so may cause damages to motherboard components.



1. Please note that the RGB LED strips do not come with the package.
2. The RGB LED header supports WS2812B addressable RGB LED strip (5V/Data/GND), with a maximum power rating of 3A (5V) and length within 2 meters.

Chapter 4 UEFI SETUP UTILITY

4.1 Introduction

This section explains how to use the UEFI SETUP UTILITY to configure your system. You may run the UEFI SETUP UTILITY by pressing <F2> or right after you power on the computer, otherwise, the Power-On-Self-Test (POST) will continue with its test routines. If you wish to enter the UEFI SETUP UTILITY after POST, restart the system by pressing <Ctl> + <Alt> + <Delete>, or by pressing the reset button on the system chassis. You may also restart by turning the system off and then back on.



Because the UEFI software is constantly being updated, the following UEFI setup screens and descriptions are for reference purpose only, and they may not exactly match what you see on your screen.

4.1.1 UEFI Menu Bar

The top of the screen has a menu bar with the following selections:

Main	For setting system time/date information
OC Tweaker	For overclocking configurations
Advanced	For advanced system configurations
Tool	Useful tools
H/W Monitor	Displays current hardware status
Security	For security settings
Boot	For configuring boot settings and boot priority
Exit	Exit the current screen or the UEFI Setup Utility

4.1.2 Navigation Keys

Use <←> key or <→> key to choose among the selections on the menu bar, and use <↑> key or <↓> key to move the cursor up or down to select items, then press <Enter> to get into the sub screen. You can also use the mouse to click your required item.

Please check the following table for the descriptions of each navigation key.

Navigation Key(s)	Description
+ / -	To change option for the selected items
<Tab>	Switch to next function
<PGUP>	Go to the previous page
<PGDN>	Go to the next page
<HOME>	Go to the top of the screen
<END>	Go to the bottom of the screen
<F1>	To display the General Help Screen
<F7>	Discard changes and exit the SETUP UTILITY
<F9>	Load optimal default values for all the settings
<F10>	Save changes and exit the SETUP UTILITY
<F12>	Print screen
<ESC>	Jump to the Exit Screen or exit the current screen

4.2 Main Screen

When you enter the UEFI SETUP UTILITY, the Main screen will appear and display the system overview.



4.3 OC Tweaker Screen

In the OC Tweaker screen, you can set up overclocking features.



Because the UEFI software is constantly being updated, the following UEFI setup screens and descriptions are for reference purpose only, and they may not exactly match what you see on your screen.

Overclock Mode(Bus Speed)

Select the overclock mode. Warning! When overlocking also the PCIe, PCI, SATA and USB busses will be overlocked which may cause instability or failure. Please install an operating system and the drivers required before overlocking, or else your HDD's may be undetectable. Overlocking is not supported if the monitor is connected via the onboard D-Bus/VGA connector.

SB Clock Spread Spectrum

Enable Spread Spectrum to reduce electromagnetic interference for passing EMI tests. Disable to achieve higher clock speeds when overlocking.

CPU Frequency and Voltage(VID) Change

If this item is set to [Manual], the multiplier and voltage will be set based on user selection. Final result is depending on the CPU's capability.

CPU Core (Per CCX)

CPU Voltage

Specifies a custom CPU core voltage, Should be combined with a custom CPU core frequency. Power saving features for idle cores (e.g. cc6 sleep) remain active.

CCD0

CCX0 Frequency (MHz)

Use this item to adjust CCX0 Frequency.

CCX1 Frequency (MHz)

Use this item to adjust CCX1 Frequency.

SoC/Uncore OC Voltage(VID)

Specify the SoC/Uncore voltage (VDD_SOC) in mV to support memory and Infinity Fabric overclocking. VDD_SOC also determines the GPU voltage on processors with integrated graphics. "SoC/Uncore OC Mode" needs to be enabled to force this voltage.

CLD0 VDDP Voltage Control

AMD Overclocking Setup VDDP is a voltage for the DDR4 bus signaling (PHY), and it is derived from your DRAM Voltage (VDDIO_Mem). As a result, VDDP voltage in mV can approach but not exceed your DRAM Voltage.

CLD0 VDDG CCD Voltage Control

AMD Overclocking Setup VDDG CCD represents voltage for the data portion of the Infinity Fabric. It is derived from the CPU SoC/Uncore Voltage (VDD_SOC). VDDG can approach but not exceed VDD_SOC.

CLD0 VDDG IOD Voltage Control

AMD Overclocking Setup VDDG IOD represents voltage for the data portion of the Infinity Fabric. It is derived from the CPU SoC/Uncore Voltage (VDD_SOC). VDDG can approach but not exceed VDD_SOC.

DRAM Information

Browse the serial presence detect (SPD) for DDR4 modules.

Load DRAM Information

Load DRAM Information.

Load XMP Setting

Load XMP settings to overclock the memory and perform beyond standard specifications.

DRAM Frequency

If [Auto] is selected, the motherboard will detect the memory module(s) inserted and assign the appropriate frequency automatically.

DRAM Voltage

Configure the voltage for the DRAM Voltage.

Infinity Fabric Frequency and Dividers

AMD Overclocking Setup Set Infinity Fabric frequency (FCLK). Auto: FCLK = MCLK. Manual: FCLK must be less than or equal to MCLK for best performance in most cases. Latency penalties are incurred if FCLK and MCLK are mismatched, but sufficiently high MCLK can negate or overcome this penalty.

GFX Clock Frequency (Only for processor with integrated graphics)

This item allows you to alter the frequency for the GFX clock frequency. After you alter the GFX Clock Frequency settings, make sure to adjust the GFX Core Voltage settings.

*The adjustable range is dependent on the CPU being installed.

GFX Core Voltage (Only for processor with integrated graphics)

This item allows you to alter the voltage for the GFX Core Voltage.

*The adjustable range is dependent on the CPU being installed.

DRAM Timing Configuration

External Voltage Settings and Load-line Calibration

CPU Core/Cache Voltage

Input voltage for the processor by the external voltage regulator.

CPU Core/Cache Load-Line Calibration

CPU Core/Cache Load-Line Calibration helps prevent CPU voltage droop when the system is under heavy loading.

CPU VCORE Switching Frequency

Configure CPU VCORE Switching Frequency.

CPU CORE/Cache Auto Phase

Configure CPU CORE/Cache Auto Phase

Configure CPU CORE/Cache Over Current Protection

Configure CPU CORE/Cache Over Current Protection.

CPU CORE/Cache Over Voltage Protection

Configure CPU CORE/Cache Over Voltage Protection.

CPU CORE/Cache SVID_VR_HOT

Configure CPU CORE/Cache SVID_VR_HOT.

CPU CORE/Cache OTP Mode

Configure CPU CORE/Cache OTP Mode.

CPU CORE/Cache OTP Setting

Configure CPU CORE/Cache OTP Setting.

CPU VDDCR_SOC Over Voltage Protection.

CPU VDDCR_SOC Over Voltage Protection.

CPU VDDCR_SOC Load-Line Calibration

CPU VDDCR_SOC Calibration helps prevent CPU voltage droop when the system is under heavy loading.

CPU VDDCR_SOC Switching Frequency

CPU VDDCR_SOC Switching Frequency.

CPU VDDCR_SOC Auto Phase

Configure CPU VDDCR_SOC Auto Phase.

CPU VDDCR_SOC Over Current Protection

Configure CPU VDDCR_SOC Over Current Protection.

CPU VDDCR_SOC Over Voltage Protection

Configure CPU VDDCR_SOC Over Voltage Protection.

CPU VDDCR_SOC SVID_VR_HOT

Configure CPU VDDCR_SOC SVID_VR_HOT.

CPU VDDCR_SOC OTP Mode

Configure CPU VDDCR_SOC OTP Mode.

CPU VDDCR_SOC OTP Setting

Configure CPU VDDCR_SOC OTP Setting.

VTT_DDR Offset Voltage (mV)

Configure the voltage for the VTT_DDR Offset Voltage(mV).

VPPM

Configure the voltage for the VPPM.

CPU VDD 1.8 Voltage

Configure the voltage for the CPU VDD 1.8 PROM.

VDDP

Configure the voltage for the VDDP.

PREM VDD_CLDO Voltage

Use this to select PREM VDD_CLDO Voltage. The default value is [Auto].

PREM VDDCR_SOC Voltage

Use this to select PREM VDDCR_SOC Voltage. The default value is [Auto].

Save User Default

Type a profile name and press enter to save your settings as user default.

Load User Default

Load previously saved user defaults.

Save User UEFI Setup Profile to Disk

Save current UEFI settings as an user default profile to disk.

Load User UEFI Setup Profile to Disk

Load previously saved user defaults from the disk.

4.4 Advanced Screen

In this section, you may set the configurations for the following items: CPU Configuration, Onboard Devices Configuration, Storage Configuration, ACPI Configuration, Trusted Computing, AMD PBS, AMD Overclocking and AMD CBS.



Setting wrong values in this section may cause the system to malfunction.

UEFI Configuration

Active Page on Entry

Select the default page when entering the UEFI setup utility.

Full HD UEFI

When [Auto] is selected, the resolution will be set to 1920 x 1080 if the monitor supports Full HD resolution. If the monitor does not support Full HD resolution, then the resolution will be set to 1024 x 768. When [Disable] is selected, the resolution will be set to 1024 x 768 directly.

4.4.1 CPU Configuration



PSS Support

Use this to enable or disable the generation of ACPI_PPC, _PSS, and _PCT objects.

NX Mode

Use this to enable or disable NX mode.

SVM Mode

When this is set to [Enabled], a VMM (Virtual Machine Architecture) can utilize the additional hardware capabilities provided by AMD-V. The default value is [Enabled].
Configuration options: [Enabled] and [Disabled].

SMT Mode

This item can be used to disable symmetric multithreading. To re-enable SMT, a power cycle is needed after selecting [Auto].

Warning: S3 is not supported on systems where SMT is disabled.

AMD fTPM Switch

Use this to enable or disable AMD CPU fTPM.

4.4.2 Onboard Devices Configuration



Turn On Onboard LED in S5

Turn on/off the LED in the ACPI S5 state.

SR-IOV Support

Enable/disable the SR-IOV (Single Root IO Virtualization Support) if the system has SR-IOV capable PCIe devices.

UMA Frame buffer Size (Only for processor with integrated graphics)

This item allows you to set the size of the UMA frame buffer.

Gnb Hd Audio

Enable/disable onboard HD audio. Set to Auto to enable onboard HD audio and automatically disable it when a sound card is installed.

Front Panel

Enable/disable front panel HD audio.

Restore on AC/Power Loss

Select the power state after a power failure. If [Power Off] is selected, the power will remain off when the power recovers. If [Power On] is selected, the system will start to boot up when the power recovers.

WAN Radio

Configure the WiFi module's connectivity.

BT On/Off

Enable/disable the bluetooth.

PS2 Y-Cable

Enable the PS2 Y-Cable or set this option to Auto.

4.4.3 Storage Configuration

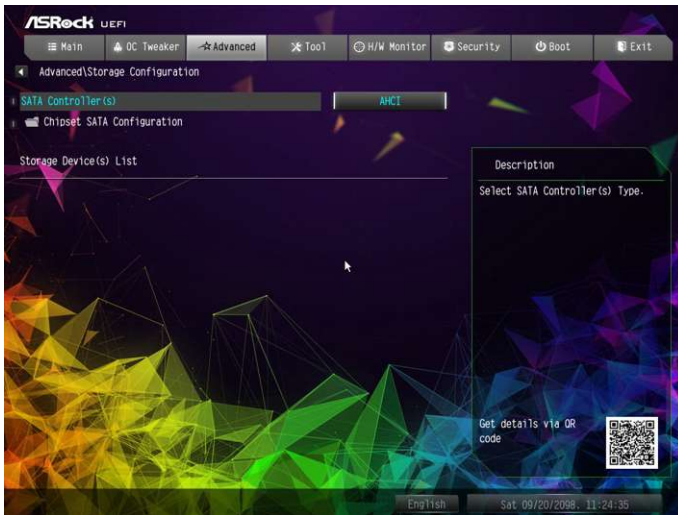

SATA Controller(s)

AHCI: Supports new features that improve performance.

RAID: Combine multiple disk drives into a logical unit.

4.4.4 ACPI Configuration



Suspend to RAM

It is recommended to select auto for ACPI S3 power saving.

Deep Sleep

Configure deep sleep mode for power saving when the computer is shut down. We recommend disabling Deep Sleep for better system compatibility and stability.

PS/2 Keyboard S4/S5 Wakeup Support

Allow the system to be waked up by a PS/2 Keyboard in S4/S5.

PCIE Devices Power On

Allow the system to be waked up by a PCIE device and enable wake on LAN.

RTC Alarm Power On

Allow the system to be waked up by the real time clock alarm. Set it to By OS to let it be handled by your operating system.

USB Power Delivery in Soft Off State (S5)

If this option is enabled, the USB port will provide power to your devices even when the system is in Power State S5.

4.4.5 Trusted Computing



Security Device Support

Enable or disable BIOS support for security device.

4.4.6 AMD PBS

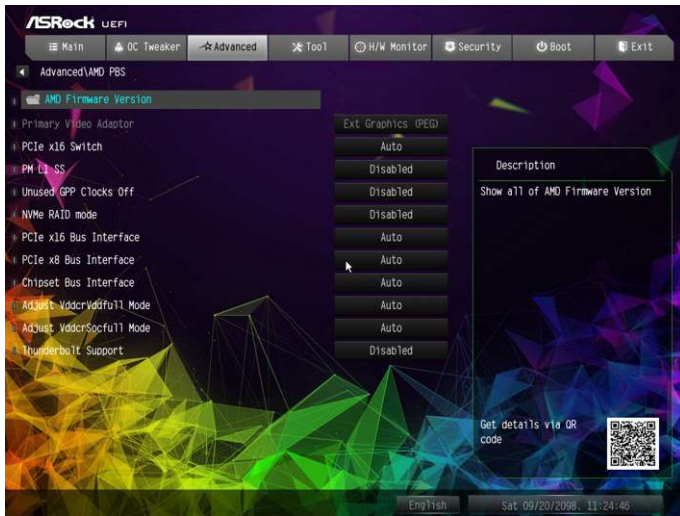

The AMD PBS menu accesses AMD specific features.

4.4.7 AMD Overclocking

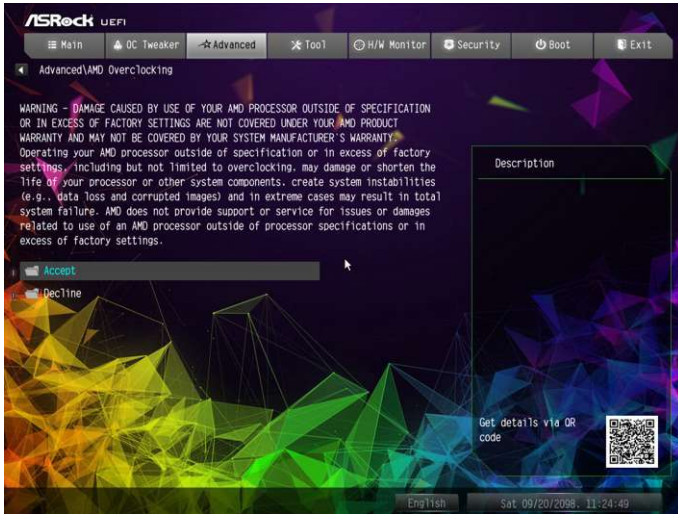

The AMD Overclocking menu accesses options for configuring CPU frequency and voltage.

4.4.8 AMD CBS

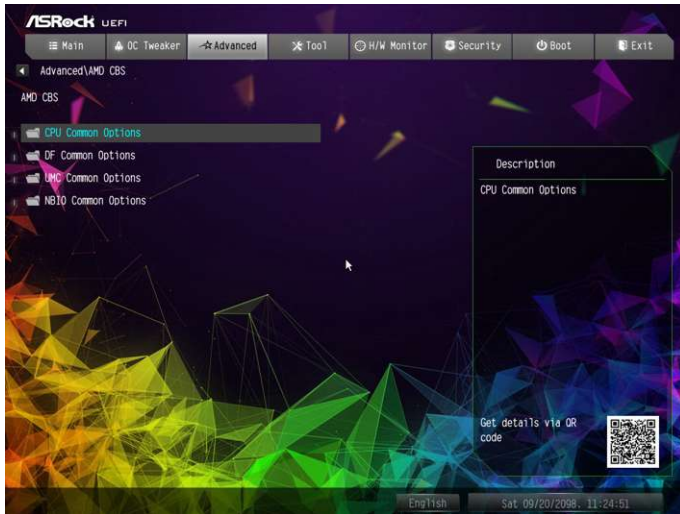

The AMD CBS menu accesses AMD specific features.

4.5 Tools

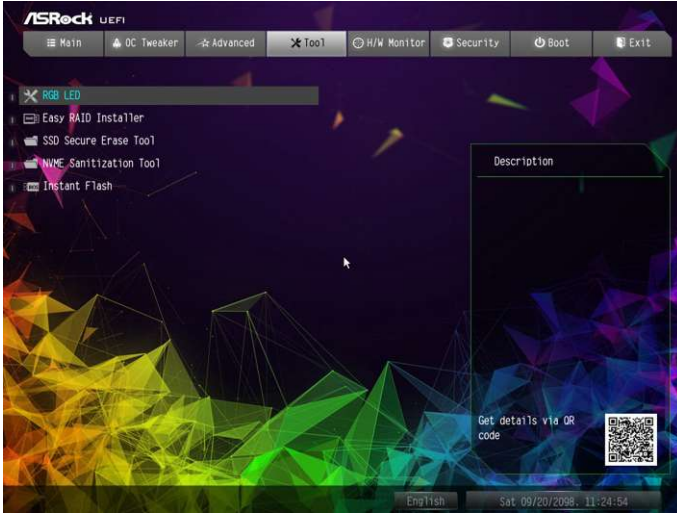

RGB LED

RGB LED allows you to turn on/off this feature.

Easy RAID Installer

Easy RAID Installer helps you to copy the RAID driver from the support CD to your USB storage device. After copying the drivers please change the SATA mode to RAID, then you can start installing the operating system in RAID mode.

SSD Secure Erase Tool

Use this tool to securely erase SSD.

NVME Sanitization Tool

After you Sanitize SSD, all user data will be permanently destroyed on the SSD and cannot be recovered.

Instant Flash

Save UEFI files in your USB storage device and run Instant Flash to update your UEFI.

4.6 Hardware Health Event Monitoring Screen

This section allows you to monitor the status of the hardware on your system, including the parameters of the CPU temperature, motherboard temperature, fan speed and voltage.



CPU_FAN1 Setting

Select a fan mode for CPU Fan 1, or choose Customize to set 5 CPU temperatures and assign a respective fan speed for each temperature.

CPU Fan 1 Step Up

Set the value of CPU Fan Step Up.

CPU Fan 1 Step Down

Set the value of CPU Fan Step Down.

CPU_FAN2 and Chassis Fan Configuration

CPU_FAN2 / WP_3A Switch

Select CPU Water Pump mode.

CPU Fan 2 Control Mode

Select PWM mode or DC mode for CPU Fan 2.

CPU Fan 2 Setting

Select a fan mode for CPU Fan 2, or choose Customize to set 5 CPU temperatures and assign a respective fan speed for each temperature.

CPU Fan 2 On/Off

Set CPU Fan 2 to On, Off, or Auto.

Select Fan Temperature Source

Select a fan temperature source for CPU Fan.

CPU Optional Fan Step Up

Set the value of CPU Optional Fan Step Up.

CPU Optional Fan Step Down

Set the value of CPU Optional Fan Step Down.

CHA_FAN1 / WP Switch

Select CHA_FAN1 or Water Pump mode.

Chassis Fan 1 Control Mode

Select PWM mode or DC mode for Chassis Fan 1.

Chassis Fan 1 Setting

Select a fan mode for Chassis Fan 1, or choose Customize to set 5 CPU temperatures and assign a respective fan speed for each temperature.

Chassis Fan 1 Temp Source

Select a fan temperature source for Chassis Fan 1.

Chassis Fan 1 Step Up

Set the value of Chassis Fan 1 Step Up.

Chassis Fan 1 Step Down

Set the value of Chassis Fan 1 Step Down.

CHA_FAN2 / WP Switch

Select CHA_FAN2 or Water Pump mode.

Chassis Fan 2 Control Mode

Select PWM mode or DC mode for Chassis Fan 2.

Chassis Fan 2 Setting

Select a fan mode for Chassis Fan 2, or choose Customize to set 5 CPU temperatures and assign a respective fan speed for each temperature.

Chassis Fan 2 Temp Source

Select a fan temperature source for Chassis Fan 2.

Chassis Fan 2 Step Up

Set the value of Chassis Fan 2 Step Up.

Chassis Fan 2 Step Down

Set the value of Chassis Fan 2 Step Down.

CHA_FAN3 / WP Switch

Select CHA_FAN3 or Water Pump mode.

Chassis Fan 3 Control Mode

Select PWM mode or DC mode for Chassis Fan 3.

Chassis Fan 3 Setting

Select a fan mode for Chassis Fan 3, or choose Customize to set 5 CPU temperatures and assign a respective fan speed for each temperature.

Chassis Fan 3 Temp Source

Select a fan temperature source for Chassis Fan 3.

Chassis Fan 3 Step Up

Set the value of Chassis Fan 3 Step Up.

Chassis Fan 3 Step Down

Set the value of Chassis Fan 3 Step Down.

CHA_FAN4 / WP Switch

Select CHA_FAN4 or Water Pump mode.

Chassis Fan 4 Control Mode

Select PWM mode or DC mode for Chassis Fan 4.

Chassis Fan 4 Setting

Select a fan mode for Chassis Fan 4, or choose Customize to set 5 CPU temperatures and assign a respective fan speed for each temperature.

Chassis Fan 4 Temp Source

Select a fan temperature source for Chassis Fan 4.

Chassis Fan 4 Step Up

Set the value of Chassis Fan 4 Step Up.

Chassis Fan 4 Step Down

Set the value of Chassis Fan 4 Step Down.

SB_FAN1 Setting

Select a fan mode for SB_FAN1, or choose Customize to set 5 CPU temperatures and assign a respective fan speed for each temperature.

Fan-Tastic

Select a fan mode for Fan, or choose Customize to set 5 CPU temperatures and assign a respective fan speed for each temperature.

FanTuning

Detect the lowest fan speed in the system. It may take 3-5 minutes to complete.

4.7 Security Screen

In this section you may set or change the supervisor/user password for the system. You may also clear the user password.



Supervisor Password

Set or change the password for the administrator account. Only the administrator has authority to change the settings in the UEFI Setup Utility. Leave it blank and press enter to remove the password.

User Password

Set or change the password for the user account. Users are unable to change the settings in the UEFI Setup Utility. Leave it blank and press enter to remove the password.

Secure Boot

Enable to support Secure Boot.

4.8 Boot Screen

This section displays the available devices on your system for you to configure the boot settings and the boot priority.



Boot From Onboard LAN

Allow the system to be waked up by the onboard LAN.

Setup Prompt Timeout

Configure the number of seconds to wait for the setup hot key.

Bootup Num-Lock

Select whether Num Lock should be turned on or off when the system boots up.

Full Screen Logo

Enable to display the boot logo or disable to show normal POST messages.

AddOn ROM Display

Enable AddOn ROM Display to see the AddOn ROM messages or configure the AddOn ROM if you've enabled Full Screen Logo. Disable for faster boot speed.

Fast Boot

Fast Boot minimizes your computer's boot time. In fast mode you may not boot from an USB storage device.

CSM (Compatibility Support Module)



CSM

Enable to launch the Compatibility Support Module. Please do not disable unless you're running a WHCK test.

Launch PXE OpROM Policy

Select UEFI only to run those that support UEFI option ROM only. Select Legacy only to run those that support legacy option ROM only. Select Do not launch to not execute both legacy and UEFI option ROM.

Launch Storage OpROM Policy

Select UEFI only to run those that support UEFI option ROM only. Select Legacy only to run those that support legacy option ROM only. Select Do not launch to not execute both legacy and UEFI option ROM.

4.9 Exit Screen



Save Changes and Exit

When you select this option the following message, “Save configuration changes and exit setup?” will pop out. Select [OK] to save changes and exit the UEFI SETUP UTILITY.

Discard Changes and Exit

When you select this option the following message, “Discard changes and exit setup?” will pop out. Select [OK] to exit the UEFI SETUP UTILITY without saving any changes.

Discard Changes

When you select this option the following message, “Discard changes?” will pop out. Select [OK] to discard all changes.

Load UEFI Defaults

Load UEFI default values for all options. The F9 key can be used for this operation.

Launch EFI Shell from filesystem device

Copy shellx64.efi to the root directory to launch EFI Shell.

Contact Information

If you need to contact ASRock or want to know more about ASRock, you're welcome to visit ASRock's website at <http://www.asrock.com>; or you may contact your dealer for further information. For technical questions, please submit a support request form at <https://event.asrock.com/tsd.asp>

ASRock Incorporation

2F., No.37, Sec. 2, Jhongyang S. Rd., Beitou District,

Taipei City 112, Taiwan (R.O.C.)

ASRock EUROPE B.V.

Bijsterhuizen 11-11

6546 AR Nijmegen

The Netherlands

Phone: +31-24-345-44-33

Fax: +31-24-345-44-38

ASRock America, Inc.

13848 Magnolia Ave, Chino, CA91710

U.S.A.

Phone: +1-909-590-8308

Fax: +1-909-590-1026

DECLARATION OF CONFORMITY

Per FCC Part 2 Section 2.1077(a)



Responsible Party Name: ASRock Incorporation

Address: 13848 Magnolia Ave, Chino, CA91710

Phone/Fax No: +1-909-590-8308/+1-909-590-1026

hereby declares that the product

Product Name : Motherboard

Model Number : X570 Taichi Razer Edition

Conforms to the following specifications:

FCC Part 15, Subpart B, Unintentional Radiators

Supplementary Information:

This device complies with part 15 of the FCC Rules. Operation is subject to the following two conditions: (1) This device may not cause harmful interference, and (2) this device must accept any interference received, including interference that may cause undesired operation.

Representative Person's Name: James

Signature:

A handwritten signature in black ink, appearing to read 'James', written over a horizontal line.

Date : May 12, 2017

EU Declaration of Conformity

ASRock®

For the following equipment:

Motherboard

(Product Name)

X570 Taichi Razer Edition / ASRock

(Model Designation / Trade Name)

ASRock Incorporation

(Manufacturer Name)

2F, No.37, Sec. 2, Jhongyang S. Rd., Beitou District, Taipei City 112, Taiwan (R.O.C.)

(Manufacturer Address)

EMC — Directive 2014/30/EU (from April 20th, 2016)

EN 55022:2010/AC:2011 Class B

EN 55024:2010/A1:2015

EN 55032:2012+AC:2013 Class B

EN 61000-3-3:2013

EN 61000-3-2:2014

RED—Directive 2014/53/EU

EN 300 328 V2.1.1

EN 301 489-17 V3.1.1

EN 301 893 V2.1.1

EN 301 489-3 V2.1.1

EN 300 220 V3.1.1

LVD — Directive 2014/35/EU (from April 20th, 2016)

EN 60950-1 : 2011+ A2: 2013

EN 60950-1 : 2006/A12: 2011

RoHS — Directive 2011/65/EU

CE marking



(EU conformity marking)

ASRock EUROPE B.V.

(Company Name)

Bijsterhuizen 1111 6546 AR Nijmegen The Netherlands

(Company Address)

Person responsible for making this declaration:

(Name, Surname)

A.V.P

(Position / Title)

November 3, 2020

(Date)

P/N: 15G062256001AK V1.0