

devolo MAGIC

Manual
devolo Magic2 LAN DINrail



devolo Magic 2 LAN DINrail

© 2022 devolo AG Aachen (Germany)

The reproduction and distribution of the documentation and software supplied with this product and the use of its contents is subject to written authorization from devolo. We reserve the right to make any alterations that arise as the result of technical development.

Trademarks

Android™ is a registered trademark of Open Handset Alliance.

Linux® is a registered trademark of Linus Torvalds.

Ubuntu® is a registered trademark of Canonical Ltd.

Mac® and Mac OS X® are registered trademarks of Apple Computer, Inc.

Windows® and Microsoft® are registered trademarks of Microsoft, Corp.

devolo and the devolo logo are registered trademarks of devolo AG.

The firmware package from devolo contains files which are covered by different licenses, in particular under devolo proprietary license and under open source license (GNU General Public License, GNU Lesser General Public License or FreeBSD License). The source code which is available for Open Source distribution can be requested in writing from gpl@devolo.de.

All other names mentioned may be trademarks or registered trademarks of their respective owners. Subject to change without notice. No liability for technical errors or omissions.

devolo AG

Charlottenburger Allee 67

52068 Aachen

Germany

www.devolo.global

Version 1.0_01/22

Contents

1	Preface	6
1.1	About this manual	6
1.2	Intended use	8
1.3	CE conformity	9
1.4	UKCA conformity	9
1.5	devolo on the Internet	9
2	Introduction	10
2.1	devolo Magic	10
2.2	Introduction to the devolo Magic adapter:	11
2.3	The devolo Magic adapter features	13
2.3.1	Line connections	13
2.3.2	Network connection	13
2.3.3	Reading the indicator light	14
2.3.4	PLC button	19
2.3.5	Reset button	20
3	Electrical installation	21
3.1	Package contents	21
3.2	System requirements	21
3.3	Important safety instructions	22
3.4	Installation	23
4	Initial use	25
4.1	Expanding an existing network	25
4.1.1	Changing the network password	25
4.2	Installation of devolo software	26
4.3	Removing the devolo Magic adapter from a network	26

5	Configuration	28
5.1	Calling up the built-in web interface	28
5.2	Menu description	28
5.2.1	Overview	30
5.2.2	Powerline	32
5.2.3	LAN	34
5.2.4	System	35
6	Appendix	40
6.1	Technical specifications	40
6.2	Disposal of old devices	40
6.3	Warranty conditions	40

1 Preface

Welcome to the fantastic world of devolo Magic!

In no time at all, devolo Magic transforms your house into a multimedia home that is ready for the future today. devolo Magic gives you noticeably higher speeds, more stability and greater range, providing the perfect Internet experience as a result!

1.1 About this manual



Carefully read all instructions before setting up the device and store the manual and/or installation guide for later reference.





After a brief introduction to „devolo Magic“ and to the devolo Magic 2 LAN DINrail in **Chapter 2**, **Chapter 3** tells you how to set up the devolo Magic 2 LAN DINrail successfully while taking into account the safety instructions. For information on configuring the dLAN network, please see **Chapter 4**. **Chapter 5** describes in detail the setting options of the built-in configuration interface. Tips for bandwidth optimisation, information about environmental compatibility of the device,





as well as our warranty terms, can be found in **Chapter 6** at the end of the manual.

Description of the icons

This section contains a brief description of the icons used in this manual and/or on the rating plate, the device connector, as well as the icons used on the package:

Icon	Description
	Very important safety symbol that warns you of hazardous electrical voltage which if not avoided can result in serious injury or death.
	Very important safety symbol that warns you of a potentially dangerous situation which if not avoided can result in serious injury or death.
	An important safety symbol that warns you of a potentially dangerous situation involving a tripping hazard which can result in injuries.

Icon	Description
	The installation may be performed by a qualified electrician only. Installations to the house wiring (230V) are only permitted to be carried out by an installation company registered in an installation directory of the network operator.
	An important note that should be observed which can potentially lead to material damages.
	The device may only be used indoors in dry conditions.
	The manufacturer/distributing company uses the CE marking to declare that the product meets all applicable European regulations and has been subjected to the prescribed conformity assessment procedures.

Icon	Description
	The manufacturer/distributing company uses the UKCA marking to declare that the product meets all applicable regulations of Great Britain and has been subjected to the prescribed conformity assessment procedures.
	It is used to prevent the occurrence of waste electrical and electronic equipment and to reduce this type of waste through reuse, recycling and other forms of utilisation. The WEEE Directive establishes minimum standards for handling waste electrical and electronic equipment in the EU, EFTA and UK.
	Additional information, background material and configuration tips for your device.
	Indicates a completed course of action

1.2 Intended use

Use devolo products, devolo software and the provided accessories as described to prevent damage and injury.

Products

devolo products are communication devices designed for indoors.* Depending on the product, they are equipped with a **PLC-** (**P**ower**L**ine **C**ommunication) and/or a Wi-Fi module. Computers, laptops, smartphones, tablets, smart TVs and other devices connected this way are integrated into a home network over the existing electrical wiring and/or Wi-Fi without any complicated wiring. devolo devices must never be used outdoors because the high temperature fluctuations and moisture can damage both the product and the power line. devolo products may not be installed at a height above **two metres** unless an additional fastening mechanism is available. The products are intended for operation in the EU, Switzerland and Norway.

* The only exceptions are devolo outdoor products, which are suited for the outdoor use thanks to their IP certification.

devolo Magic 2 LAN DINrail

The intended use of the devolo Magic 2 LAN DINrail is connecting devices

in the installation area (e.g. Internet access device) to the household dLAN network for data transmission (e.g. Internet data).

The devolo Magic 2 LAN DINrail is intended for installation on the top-hat rail in the installation area of overvoltage category 3 or lower.

Software

devolo devices can be used only with the free, downloadable programs approved and available on devolo AG's website (www.devolo.global) and in app stores (iOS and Google Play). Any modifications to the product-specific firmware or software could damage the products and, in the worst-case scenario, render them unusable and negatively affect conformity.

Always use the most up-to-date software version to make sure you have the latest security functions and device updates. The installed devolo software notifies you automatically if a new software version is available.

Accessories

Use only the provided accessories.

1.3 CE conformity

CE This product complies with the technical requirements of the directives **2014/35/EU, 2014/30/EU, 2011/65/EU** und **2009/125/EC**.

This product is designed for use in the EU, EFTA and Northern Ireland.

A printout of the simplified CE declaration of this product is separately included.

The CE declaration and can also be found under www.devolo.global/support/ce.

1.4 UKCA conformity

**UK
CA** This product complies with the technical requirements of the following regulations:

- Electromagnetic Compatibility Regulations 2016 (**SI 2016 No. 1091**)
- Electrical Equipment (Safety) Regulations 2016 (**SI 2016 No. 1101**)
- Ecodesign for Energy-Related Products and Energy Information (Amendment) (EU Exit) Regulations 2010 (**2010 No. 2617**)

- Restriction of the Use of Certain Hazardous Substances in Electrical and Electronic Equipment Regulations 2012 (**SI 2012 No. 3032**)

This product is designed for use in UK.

A printout of the simplified UKCA declaration of this product is separately included.

The UKCA declaration and can also be found under www.devolo.global/support/UKCA.

1.5 devolo on the Internet

For detailed information on our products, visit www.devolo.global.

There you will find product descriptions and documentation, and also updates of devolo software and your device's firmware.

If you have any further ideas or suggestions related to our products, please don't hesitate to contact us at support@devolo.global!

Like the HomePlug AV technology used in established devolo dLAN devices, devolo Magic uses the household mains supply for data transmission and secures ideal performance and stability in locations where network cables are not viable or desired and/or the Wi-Fi frequently falls short due to ceilings and walls.



To set up a devolo Magic network, you need at least two devolo Magic devices. For technical reasons, devices from the devolo Magic series are not compatible with dLAN devices.

2.2 Introduction to the devolo Magic adapter:

The devolo Magic 2 LAN DINrail is the G.hn-based Powerline adapter for the central integration of Powerline technology in control cabinets and distribution boxes.

It is a high-performance networker directly from a DIN rail.

The Gigabit LAN port on the devolo Magic 2 LAN DINrail lets you connect to your Internet router.

- **Speed and stability** – thanks to consistent data transmission speed at up to **2400 Mbps** over distances of **up to 500 meters**, the devolo Magic 2 LAN DINrail promises entertainment at the highest level.
- **Security** – with **128-bit AES** Powerline encryption
- **Energy-efficiency** – the integrated PowerSave mode cuts energy consumption automatically **during low data traffic**.

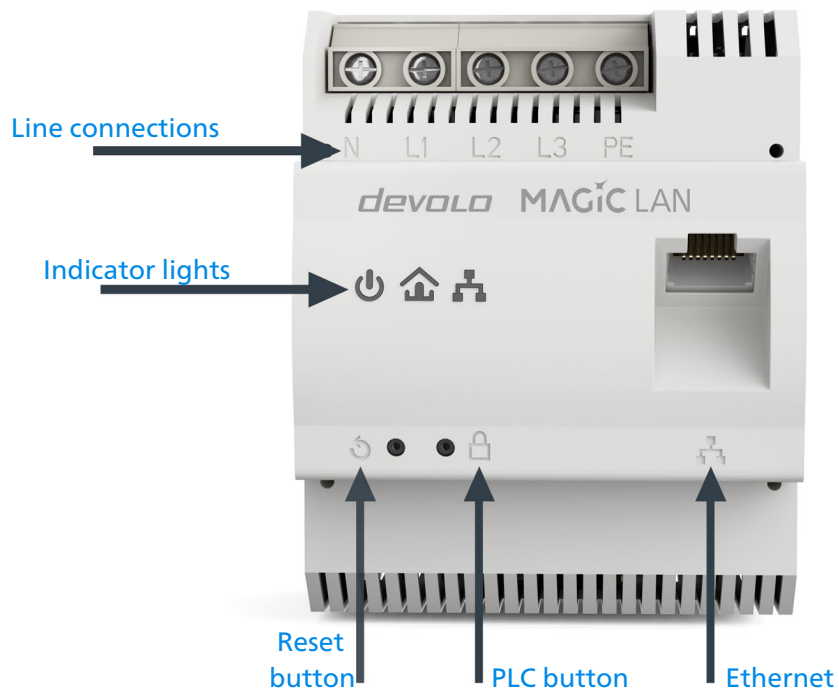



Fig.2

2.3 The devolo Magic adapter features

- Five line connections
- One Gigabit network connection
- Three indicator lights
 - Power
 - PLC
 - Ethernet

 *The LED status display can be disabled. You can find more information about this in Chapter 5 Configuration or in the product manual for the devolo Cockpit software available online at www.devolo.global/devolo-cockpit.*

- One PLC button
- One reset button

2.3.1 Line connections

This is where you connect the conductors to the corresponding line connections.

Single-phase connection: Neutral conductors and external conductors are connected to terminals N and L1.

Three-phase connection: Neutral conductors and three external conductors are connected to terminals N, L1, L2 and L3. The device is supplied with power via terminals N and L1.

PE connection: Connecting the earth wire to the PE terminal

The permitted **conductor cross-section** for connection to the terminals is **0.18 mm² to 6 mm²**.

2.3.2 Network connection

You can use the network connection (Fig. 2) on the devolo Magic adapter to connect it to your internet router using standard network cables.

2.3.3 Reading the indicator light

The integrated indicator lights (**LED**) show the status for the devolo Magic 2 LAN DINrail by illuminating and/or flashing:



Power (Fig. 2)

	Power-LED	Flashing behaviour	Meaning	LED status display (web interface*)
1	White LED	Lights up	devolo Magic adapter is ready to operate	Can be disabled

*Information about the web interface can be found in Chapter **5 Configuration**.



PLC (Fig. 2)

	PLC-LED	Flashing behaviour	Meaning	LED status display (web interface*)
1	Red LED	Lights up for up to 2 sec.	Start-up process	Cannot be disabled
2	Red LED	Flashes at intervals of 0.5 sec. (on/off)	<p>Status 1: The reset of the devolo Magic adapter was successful. The reset button has been pressed and held for 10 seconds.</p> <p>Status 2: The devolo Magic adapter (once again) has the factory default settings. Since the last reset, no pairing with another devolo Magic adapter has taken place. Connect the adapter with another devolo Magic adapter to create a full-fledged PLC network as described in Chapter 4 Initial use.</p>	Cannot be disabled

	PLC-LED	Flashing behaviour	Meaning	LED status display (web interface*)
3	Red LED	Lights up steady	<p>Status 1: The other network nodes are in standby mode and cannot currently be accessed over the mains supply. The PLC LEDs of the other devolo Magic adapters flash white only for a short time.</p> <p>Status 2: The connection to the other network nodes has been interrupted. There may be electromagnetic or radio frequency interference on the power line. In this case, put the devolo Magic adapters closer to each other or try to shut off the source of interference.</p>	Can be disabled
4	Red and white LED	<p>Red: flashes at intervals of 0.25 sec. on/ 2 sec. off.</p> <p>White: flashes at intervals of 2 sec. on/ 0.25 sec. off</p>	Data transmission rate not in optimum range	Can be disabled

	PLC-LED	Flashing behaviour	Meaning	LED status display (web interface*)
5	White LED	<p>Status 1: Flashes at intervals of 0.5 sec. (on/off)</p> <p>Status 2: Flashes at intervals of 1 sec. (on/off)</p>	<p>Status 1: This devolo Magic adapter is in pairing mode and the system is searching for new devolo Magic adapters.</p> <p>Status 2: Someone has triggered the "Identify device" function on the web interface or in the devolo Home Network App. This function identifies the devolo Magic adapter being sought.</p>	Cannot be disabled
6	White LED	Lights up steadily	The devolo Magic connection does not have any issues and the devolo Magic adapter is ready to operate.	Can be disabled
7	White LED	Flashes at intervals of 0.25 sec. on/ 3 sec. off	The devolo Magic adapter is in standby mode.**	Can be disabled
8	Red and white LED	Flashes at intervals of 0.3 sec. red/ 0.3 sec. white	The devolo Magic adapter is carrying out a firmware update.	Cannot be disabled

* Information about the web interface can be found in Chapter **5 Configuration**.

**A devolo Magic adapter switches to standby mode after approximately 10 minutes if no active network device (e.g. computer) is connected to the network interface. In this mode, the devolo Magic adapter cannot be accessed over the electrical wiring. As soon as the network device (e.g. computer) connected to the network interface is switched on again, your devolo Magic adapter can also be accessed over the electrical wiring again.



*Check whether the adapter is connected to the mains supply correctly and whether the pairing operation has been carried out successfully. For more information about this, refer to **3 Electrical installation**.*



Ethernet (Fig. 2)

	Ethernet-LED	Flashing behaviour	Meaning	LED status display (web interface*)
1	White LED	Lights up steady	Connection to the Ethernet network	Cannot be disabled
2	White LED	Flashes	Data transmission	Cannot be disabled
3	White LED	Off	Standby mode	Cannot be disabled

*Information about the web interface can be found in Chapter 5 **Configuration**.

2.3.4 PLC button

devolo Magic adapters that are in factory default condition, i.e. have been purchased or successfully reset, automatically start to attempt to pair with another devolo Magic adapter when reconnected to the mains supply.

Expanding an existing devolo Magic network by adding another devolo Magic adapter

In order to use a new devolo Magic 2 LAN DINrail in your devolo Magic network, first you have to connect it to your existing devolo Magic adapters devices as a network. This is accomplished by using a shared password, which can be assigned in various ways:

- Using **devolo Cockpit** or the **devolo Home Network App** (see Chapter 4.2 **Installation of devolo software**)

- Using the **web interface** (see Chapter 5.2.2 **Powerline**)

- Using the **PLC button** (see Fig. 2)

 Detailed information to install the devolo Magic adapter can be found in chapter 3 **Electrical installation**.

Resetting a devolo Magic adapter or removing it from a devolo Magic network

 All safety and operating instructions in chapter 3.3 **Important safety instructions** should be read and understood before carrying out an electrical uninstall of the device.

To remove a devolo Magic adapter from your devolo Magic network and successfully restore its entire configuration to the factory default settings, press and **hold the PLC button longer than 10 seconds**. The LEDs remain enabled. Wait until the PLC LED flashes white and integrate the device into another network; proceed as described in chapter 4.1 **Expanding an existing network**.

Keep in mind that all settings that have already been made will be lost!

2.3.5 Reset button

Rebooting the devolo Magic adapter

The device is restarted by pressing the reset button (Fig. 2). The LEDs switch off in the meanwhile.

3 Electrical installation

In this chapter we describe the electrical installation of the devolo Magic 2 LAN DINrail on the top-hat rail in the power distribution box.

3.1 Package contents

Please ensure that the delivery is complete before beginning with the installation of your devolo Magic 2 LAN DINrail:

- 1 devolo Magic 2 LAN DINrail
- 1 Network cable
- Hard copy of installation guide
- Hard copy of security flyer
- Hard copy of simplified CE/UKCA declaration

devolo AG reserves the right to change the package contents without prior notice.

3.2 System requirements

- **Operating systems supported by devolo Cockpit:**
 - from Windows 7 (32-bit/64-bit),
 - from Ubuntu 13.10 (32-bit/64-bit),
 - from Mac (OS X 10.9)

- **Gigabit network connection**

- **Network connection**



Please note that your computer or other device must have a network card or network adapter with a network interface.

To set up a devolo network, you need at least two devolo adapters.

3.3 Important safety instructions

All safety and operating instructions should be read and understood before using the device, and should be kept for future reference.



DANGER! Shock hazard

Installations to the house wiring (230V or 400V) (*according to the German Low-Voltage Connection Ordinance—NAV § 13) are only permitted to be carried out by an installation company registered in an installation directory of the network operator.



The work must be performed by a suitably qualified electrician (according to DIN VDE 0105-100). The accepted rules of electrical engineering (pursuant to the German Energy Act § 49 and DIN VDE 0100) must be complied with. It is essential that the mains power supply (main switch/circuit breaker/switch off fuse) is disconnected and secured against being switched back on to avoid an electrical shock from the device. Use a suitable measuring instrument to verify safe isolation from the power supply before work is commenced.



DANGER! Shock hazard

Components powered by the mains supply have to be secured with a circuit breaker.

An easily accessible disconnecter (such as a circuit breaker) must be available for each connected external conductor.

- The device is intended for installation on the top-hat rail in the installation area of overvoltage category 3 or lower.
- Never open the device. There are no user-serviceable parts inside the device.
- Use the device in a dry location only.
- Do not insert any objects into the openings of the device.
- Slots and openings on the case serve as ventilation. Never block or cover them.
- Do not keep the device in direct sunlight.
- Never set up the device near a heater or radiator.
- The device should be located only where sufficient ventilation can be ensured.
- Never use the device with a power supply that does not meet the specifications provided on the rating plate.
- In the event of damage, contact customer service. This applies, for example, if

- liquid has been spilled on the device or objects have fallen into the device.
- the device has been exposed to rain or water.
- the device does not work, even though the operating instructions have been followed properly.
- the device's case is damaged.

3.4 Installation

- 1 Install the devolo Magic 2 LAN DINrail properly on the top-hat rail.

 *Take into account the vertical installation alignment of the device, so that the mains power supply comes from above.*

- 2 Now connect the conductors according to the line connections.

 *When connecting to the sockets, make sure the conductor cross-section is 0.18 mm² to 6 mm².*



DANGER! Risk of fire caused by incorrect conductor cross-section and improper installation of the power supply. Comply with the specified conductor cross-sections and ensure the power supply is correctly installed.

- **Single-phase connection:** Neutral conductors and external conductors are connected to terminals **N** and **L1** (see Fig. 3).
- **Three-phase connection:** Neutral conductors and three external conductors are connected to terminals **N**, **L1**, **L2** and **L3**. The device is **supplied with power** via terminals **N** and **L1** (see Fig. 4).
- **PE connection:** The earth wire must be connected to the PE terminal.

Single-phase connection without residual current circuit breaker

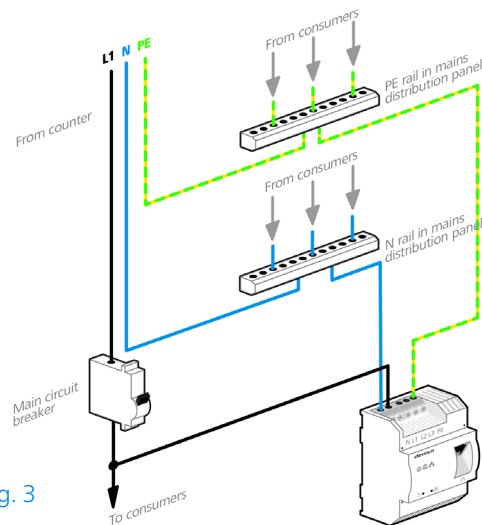

Fig. 3

i In general, connection of the devolo Magic 2 LAN DINrail to one phase and to one neutral conductor is adequate, even for communicating over multiple phases. To optimise the data transmission, however, we recommend a connection with all three-phases and earth wire (PE).

Three-phase connection without residual current circuit breaker

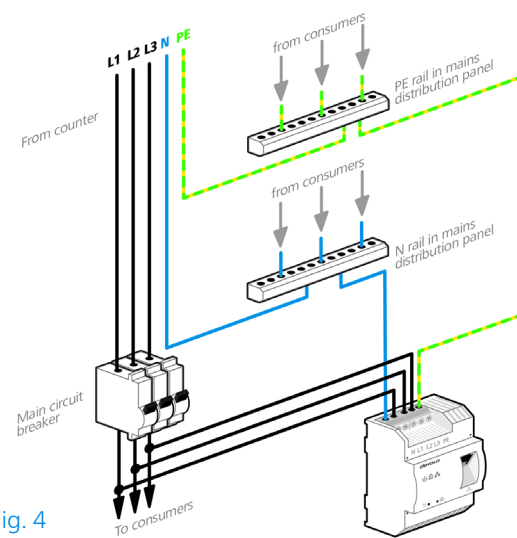

Fig. 4

- After installing the protective cover, the devolo Magic 2 LAN DINrail can be connected via Ethernet to the desired network device (e.g. Internet router).

As soon as at least one other devolo Magic device has been connected and plugged into the mains supply, a PLC network is set up. For information on how to proceed, refer to Chapter 4 **Initial use**.

4 Initial use

This chapter tells you how to integrate the devolo Magic 2 LAN DINrail into an existing devolo Magic network. We briefly describe the devolo software.

For more information, please visit our website www.devolo.global.

4.1 Expanding an existing network

Before you can use the devolo Magic 2 LAN DINrail in your devolo Magic network, first you have to connect it to your existing devolo Magic adapters as a network. This is accomplished by using a shared password.

- ❶ You installed the devolo Magic 2 LAN DINrail properly on the top-hat rail and connected it to the desired network device (e.g. Internet router) as described in Chapter **3 Electrical installation**.
- ❷ Within 3 minutes, press the PLC button on a devolo Magic adapter in your existing devolo Magic network for approximately 1 sec.



The new devolo Magic adapter pairs automatically so no button needs to be pressed. The LED of this adapter now also flashes white.



If the LEDs light up white on both devolo Magic adapters, the new adapter has been successfully integrated into your existing devolo Magic network.



For each pairing operation, only one additional adapter can be added at a time.

4.1.1 Changing the network password

A network password can also be changed in the following ways:

- Using the **web interface** of the devolo Magic adapter (see Chapter **5.2.2 Powerline**)
- Using **devolo Cockpit** or the **devolo Home Network App**. For more information, refer to the following chapter.

4.2 Installation of devolo software

Installing devolo Cockpit software

devolo Cockpit finds all accessible devolo Magic adapters in your devolo Magic network, displays information about these devices and encrypts your devolo Magic network individually. You can use the software to navigate to the integrated web interface.

Operating systems supported by devolo Cockpit (Version 5.0 or later):

- from Windows 7 (32-bit/64-bit) or later,
- from Ubuntu 13.10 (32-bit/64-bit),
- from Mac (OS X 10.9)

 You can find the product manual, software and additional information on devolo Cockpit online at www.devolo.global/devolo-cockpit.

Downloading the devolo Home Network App

The devolo Home Network App is devolo's **free app** also for checking and configuring WiFi, PLC and LAN connections for the devolo Magic adapter (using a smartphone or tablet). The smartphone or

tablet connects to the devolo Magic adapter at home over Wi-Fi.

- 1 Download the devolo Home Network App to your smartphone or tablet computer from the corresponding store.
- 2 The devolo Home Network App is placed in your smartphone's or tablet's app list as usual. Tapping on the devolo Home Network App icon brings you to the start menu.

 You can find more information about the devolo Home Network App online at www.devolo.global/home-network-app.

4.3 Removing the devolo Magic adapter from a network

To remove a devolo Magic adapter from your network and successfully restore its entire configuration to the factory default settings, press the reset **button longer than 10 seconds**. The LEDs remain enabled. Wait until the PLC LED flashes white and integrate the device into another network.

Keep in mind that all settings that have already been made will be lost!

To integrate the mains supply into another network, proceed as described in Chapter **4.1 Expanding an existing network**.



*All safety and operating instructions in chapter **3.3 Important safety instructions** should be read and understood before carrying out an electrical uninstall of the device.*

5 Configuration

The devolo Magic 2 LAN DINrail has a built-in web interface that can be called up using a standard web browser. Here, you can read out device information and configure some settings for operating the devolo Magic adapter.

5.1 Calling up the built-in web interface

You can access the built-in web interface for the devolo Magic 2 LAN DINrail in different ways:

- Using the **devolo Home Network App** on your smartphone or tablet, you can access the device's web interface by tapping on the corresponding adapter symbol for the devolo Magic 2 LAN DINrail.
- Using the **devolo Cockpit software**, you can access the web interface of the devolo Magic adapter by clicking on the tab for the **device's configuration page**.

Then the program determines the current IP address and starts the configuration in the web browser.



You can find more information on devolo software in Chapter **4.2 Installation of devolo software**.

5.2 Menu description

All menu functions are described in the corresponding interface as well as in the associated chapter in the manual. The sequence of the description in the manual follows the structure of the menu.

The central web interface areas are displayed at the edge of the screen. Click a menu to switch directly to that menu.

 Overview

 Powerline

 LAN

 System

Logging in

The web interface is not password protected. Assigning a login password is mandatory when log-

ging in for the first time to prevent unauthorised access by third parties.



You can find more information on the login process in Chapter 5.2.4 System.

Enter your existing password each time you login again and confirm by pressing **Log in**.

Logging out



Log out of the web interface by clicking **Log out**.

Language selection



Select the desired language in the language selection list.

Making changes

Once you make a change, two icons are shown on the corresponding menu page:

- **Disk** icon: Your settings are being saved.

- **X** icon: The operation is being cancelled. Your settings are not being saved.

Required fields

Fields with a red border are required fields. This means entries must be made in these fields to continue with the configuration.

Help text blank fields

Fields that have not been filled in yet contain greyed out help text, which indicates the required content for the field. This help text disappears immediately once content has been entered.

Default settings

Some fields contain default settings which ensure the greatest amount of compatibility and ease of use. Default settings are identified with an * in drop-down menus.

Default settings can of course be replaced with customised information.

Recommended settings

Some fields include recommended settings.

Recommended settings can of course be replaced with customised information.

Invalid entries

Entry errors are either highlighted by a red border or error messages are shown.

Buttons

Click the **Disk** icon to save the settings for the respective web interface area.

Click the **X** icon or use the **Menu path** above the buttons to exit the respective web interface area.

Click the **Recycle bin** icon to delete an entry.

Click the **Arrow** icon to refresh a list.

5.2.1 Overview

In the **Overview** area, you will find information on hardware and software for the devolo Magic adapter and network details.

System		LAN	
Information			
Name:	devolo-002	Ethernet:	
MT number:		LAN port 1:	Not connected
Serial number:	1902011230000002	IPv4	
MAC address:	b8:be:f4:00:00:02	DHCP:	enabled
Firmware version:		Address:	172.25.201.171
System uptime:	12 days, 03:37:16	Netmask:	255.255.0.0
		Default gateway:	172.25.5.1
		Name server:	172.25.1.12
		IPv6	
		Link-local address:	fe80::babe:f4ff:fe00:2/128
		SLAAC address:	2a00:fe0:313:25:babe:f4ff:fe00:2/64
		Name server:	::
Powerline			
Local Device			
Device state:	Connected		
Network			
Connected clients:	3		
Connections			
Device ID	MAC address	Transmit (Mbps)	Receive (Mbps)
1	30:d3:2d:a9:80:c2	478	965
2 (this device)	b8:be:f4:00:00:02	0	0
3	b8:be:f4:03:d5:5b	1234	517
4	b8:be:f4:00:04:b3	1032	1002

System

Name: Device name

MT number: Device type number

Serial number: Device serial number

MAC address: MAC address of the device

Firmware version: Firmware version of the device

System uptime: Operating time since the last restart

LAN – Ethernet

LAN port: network connection; if a connection has been detected, the speed (10/100/1000 Mbps) and the mode (half/full duplex) are specified; otherwise, the status "unconnected" is specified.

LAN – IPv4

DHCP: Display indicating whether DHCP is switched on or switched off

Address: IPv4 address in use

Netmask: IPv4 network mask in use

Default gateway: IPv4 gateway in use

Name server: DNSv4 server in use

LAN – IPv6

Link-local address: Link-local address in use

SLAAC address: SLAAC address in use

Name server: DNSv6 server in use

Powerline

Local device: Status information „connected“ or „not connected“

Network: Number of devices connected to the network

Connections

The table lists all available and connected devolo Magic adapters for your network along with displaying the following details:

Device ID: number of the respective devolo Magic adapter in the devolo Magic network

MAC address: MAC address of the respective devolo Magic adapter

Transmit (Mbps): Data transmission rate

Receive (Mbps): Data reception rate



You can find more detailed information on the displayed network details in Chapter 5.2.3 LAN.

5.2.2 Powerline

In the **Powerline** area, you will find functions and information on the topic of Powerline and adapter pairing.

Powerline Network

To form one Powerline network, all devices need to receive a common encryption password.

This happens automatically if you initiate pairing by pressing the Powerline button on two or more devices in succession. The automatically generated password of the first device will be assigned to all other devices.

Instead of pressing the physical button on the device itself, you can also activate the following button.

Start pairing

When you activate the following button, the current password will be deleted.

Leave Powerline network

Instead of the auto-generated password, you can also assign your own password for encryption. The same password must be entered for all devices which should be part of the same Powerline network.

Powerline password: 

Powerline domain name:

In order to use a new devolo Magic 2 LAN DINrail in your devolo Magic network, first you have to connect it to your existing devolo Magic adapters devices as a network. This is accomplished by using a shared password. This can be assigned in different ways:

- Using **devolo Cockpit** or the **devolo Home Network App** (see Chapter **4.2 Installation of devolo software**),
- Only using the **PLC button** (see Chapter **2.3.4 PLC button** and **4.1 Expanding an existing network**)
- Using the web interface, in the **Powerline** menu; as described below:

Pairing – Using on-screen button

- 1 Click **Start pairing** to start the pairing operation. This may take some time.
- 2 As soon as the new devolo Magic adapter is integrated into your existing network, it appears in a list of available and established connections (see Chapter **Connections**).

Pairing – Using custom password

You can also assign your network a custom PLC password you pick yourself. Enter this password for each devolo Magic adapter in the **Powerline password** field and confirm your entry with **OK**.

Note that the custom password is not assigned to the whole PLC network automatically. Instead, you must assign it separately to each of your devolo Magic adapters.

Powerline domain name

The Powerline domain name determines the name of your PLC network.

Unpairing – Resetting or removing an adapter from a network

- 1 To remove a devolo Magic adapter from your devolo Magic network, click **Leave Powerline network**.
- 2 Wait until the PLC LED flashes white and then disconnect the devolo Magic adapter from the mains supply.

Compatibility mode

Using as VDSL connection may negatively impact the performance of the bandwidth connection by crosstalk of the signal.

Compatibility Mode

In rare cases, VDSL connection problems can be caused by crosstalk with the powerline signal. If automatic compatibility mode is enabled, the device will try to detect this situation and adjust its output signal accordingly, which should provide the best balance between performance and mitigation of crosstalk.

Automatic compatibility mode (recommended) *

If automatic mode is disabled, or cannot reliably detect crosstalk, a static mitigation profile will be used instead. Select the profile which matches the type of your VDSL connection, or select "Full Power" for no mitigation at all.

MIMO SISO

* Changes will have effect after system reboot.

In order to mitigate any potential negative effects the device provides the following options:

Automatic compatibility mode

If the option **Automatic compatibility mode (recommended)** is enabled, the device can automatically adjust the output signal to avoid interference as much as possible. This option is configured by default.

Manual compatibility mode

If an interference has not been eliminated despite activating the automatic setting, please disable it and set the compatibility mode as well as the signal transmission profile manually:

- MIMO
 - Full power
 - VDSL 17a (default)
 - VDSL 35b
- SISO
 - Full power
 - VDSL 17a (default)
 - VDSL 35b



Get in touch with your internet provider to find out which signal transmission profile is the best option for your internet connection.

The MIMO operating mode and the VDSL 17a signal transmission profile are configured by default.

5.2.3 LAN

You make changes to the network settings in the **LAN** area.

IPv4 Configuration

DHCP enabled

IPv6 Configuration

DHCPv6 enabled

Address:

Prefix:

Default gateway:

Name server:

All changes except the name server will have effect after system reboot.

You can access the web interface for the devolo Magic 2 LAN DINrail using its current IP address. This may be an IPv4 and/or IPv6 address, which is either entered manually as a static address or automatically retrieved from a DHCP server.

IPv4 Configuration

In the factory default settings, only the **DHCP enabled** option for **IPv4** is enabled. This means that the IPv4 address is retrieved axiomatically

from a DHCP server. The currently assigned network data is visible (greyed out).

If a DHCP server is already present on the network for giving out IP addresses (e.g. your Internet router), you should enable the **DHCP enabled** option so that the devolo Magic 2 LAN DINrail automatically receives an address from it.

If you want to assign a static IP address, make entries accordingly for the **Address**, **Subnetmask**, **Default gateway** and **Name server** fields.

Confirm your settings by clicking the **Disk** icon.

Then, restart the devolo Magic adapter (see Chapter **Reboot**) to ensure that your changes take effect.

IPv6 Configuration

If you want automatic IP address assignment and there is already a DHCP server present on the network for giving out IP addresses (e.g. your Internet router), enable the **DHCPv6 enabled** option to ensure that the devolo Magic 2 LAN DINrail automatically receives an address from this device.

If you want to assign a static IP address, make entries accordingly for the **Address**, **Prefix**, **Default gateway** and **Name server** fields.

Confirm your settings by clicking the **Disk** icon.

Then, restart the devolo Magic adapter (see Chapter **Reboot**) to ensure that your changes take effect.

5.2.4 System

In the **System** area, you can configure the settings for security and other devolo Magic adapter device functions.

System Information

System information lets you enter an user-defined name in the **Device name (hostname)** field. This information is particularly helpful if multiple

devolo Magic adapters are to be used and identified in the network.

System Information

Device name (hostname):

Password

Set a new password to protect this webinterface.

Enter new password:

Confirm new password:

Identify Device

Activate this button to identify this device. The LED will flash fast in white for two minutes.

Password.

You can set a login password for accessing the web interface.

By default, the built-in web interface of the devolo Magic 2 LAN DINrail is not protected by a password. We recommend assigning a password when the installation of the devolo Magic 2 LAN DINrail is complete to protect it against tampering by third parties.

To do so, enter the desired new password twice. Now the web interface is protected against unauthorised access with your custom password!

Identify Device

The devolo Magic adapter can be located using the **Identify device** function. Click **Identify** to make the white PLC LED for the corresponding adapter flash for 2 minutes to make it easier to identify by sight.

LED

Enable the **LED disabled** option if the LEDs on the devolo Magic adapter are intended to be switched off for normal operation. An error status is indica-

ted by corresponding flashing behaviour regardless of this setting.

LED

You can disable the LED. This applies to normal operation, e.g. when the device is connected to a Powerline network or has entered standby mode. The LED still indicates ongoing pairing or connection problems.

LED disabled

Powersaving

Allow device to enter powersaving mode if reduced ethernet traffic is detected. Warning: Latency might increase when very slow traffic is detected.

Powersaving enabled

Standby

Allow device to enter standby mode if no ethernet link is detected. Warning: This device becomes unreachable via PLC network when ethernet link is off.

Standby enabled

Powersaving

If **Powersave** mode has been enabled, the devolo Magic 2 LAN DINrail switches to Powersave mode automatically whenever reduced data transmission over ethernet is detected.

 *The latency (time for transmitting a data packet) may be negatively affected.*

Powersave mode is disabled in the devolo Magic 2 LAN DINrail factory default settings.

Standby

If **Standby** mode is enabled, the devolo Magic 2 LAN DINrail automatically switches to Standby mode if no ethernet connection has been enabled, i.e. if no network device (e.g. computer) is switched on and connected to the network interface and if Wi-Fi is disabled.

In this mode, the devolo Magic 2 LAN DINrail is not accessible over the Powerline network. As soon as the network device (e.g. computer) connected to the network interface is switched on again, your adapter can also be accessed over the electrical wiring again.

Standby mode is enabled in the devolo Magic 2 LAN DINrail factory default condition.

Firmware update

 *The currently installed firmware of the devolo Magic adapter is displayed on the overview page (see **5.2.1 Overview**).*

The firmware of the devolo Magic 2 LAN DINrail includes the software for operating the device. If necessary, devolo offers new versions on the Internet as a file download. **The firmware update can be initiated automatically or manually.**

Firmware update

Your device can check regularly for firmware updates on the devolo update server. New versions can be installed either manually or completely automatic at night.

- Regularly check for firmware updates
- Automatically install firmware updates

Instead of using the devolo update server, you can also upload a new firmware file from your computer. You can download them from the devolo Website.

Browse for firmware file ...

Regularly check for firmware updates

The devolo Magic 2 LAN DINrail can look for up-to-date firmware automatically. To do this, enable the option **Regularly check for firmware updates**.

The devolo Magic 2 LAN DINrail lets you know when a new firmware version becomes available and asks if firmware should be updated.

Automatically install firmware updates

With the option **Automatically install firmware updates** enabled, the devolo Magic 2 LAN DINrail automatically installs the firmware it has found.

Manually initiate a firmware update

- 1 In order to manually update the firmware, visit the devolo website.
- 1 Download the appropriate file for the devolo Magic 2 LAN DINrail to your computer.
- 2 Next, click on **Browse for firmware file...** and select the downloaded firmware file.
- 3 Confirm your settings by clicking the **diskette** icon. After a successful update, the devolo Magic 2 LAN DINrail restarts automatically.

Ensure that the update procedure is not interrupted.

Reboot

To restart a devolo Magic adapter, click **Reboot**.

Reboot

When you activate this button, the device will be restarted.

Reboot

Factory Settings

When you activate this button, all device settings will be deleted and the configuration will be reset to factory defaults.

Factory reset

Factory Settings

- 1 To remove a devolo Magic adapter from your devolo Magic network and successfully restore its entire configuration to the factory default settings, click **Factory reset**.
- 2 Wait until the PLC LED flashes white and then disconnect the devolo Magic adapter from the mains supply.

 *Keep in mind that all settings that have already been made will be lost!*

6 Appendix

6.1 Technical specifications

Security	128 Bit AES
Device port	3 x phase N, PE 1x Ethernet RJ45
Power consumption	Maximum: 5.2 W Typical (P-on): 4.4 W Stand-by: 0.8 W
Power supply	internal 196-250 V AC 50 Hz
Temperature (Storage/Operating)	-25°C to 70°C/ 0°C to 55°C
Dimensions (in mm)	90x73x66 (HxWxD)
Ambient conditions	10-90% Humidity, non-condensing
Certifications	CE, UKCA

6.2 Disposal of old devices

To be used in the countries of the European Union and other countries with a separate collecting system:



The icon with crossed-out wastebasket on the device means that this product is an electrical or electronic device that falls within the scope of application of the WEEE Directive. These types of devices may no longer be disposed of with household waste. Rather they can be given to a municipal collection point free of charge. Contact your municipal government to find out the address and hours of the nearest collection point.

6.3 Warranty conditions

If your devolo device is found to be defective during initial installation or within the warranty period, please contact the vendor who sold you the product. The vendor will take care of the repair or warranty claim for you. The complete warranty conditions can be found at www.devolo.global/support.

A

Adapter equipment 13

C

CE declaration 9

Changing/assigning the network password 19, 25

Circuit breaker 22

Conductor cross-section 13

D

devolo App 26

devolo Cockpit 26

devolo Magic 10

devolo software 26

DHCP server 35

Disposal of old devices 40

E

Earth wire 13, 23

Expanding an existing devolo Magic network 19

External conductor 23

F

Factory reset 20, 26, 39

I

Installation alignment 23

Intended use 8

IP address 34

IPv4 34

L

LED status display 13, 14

Login password 28

N

Network connection 13

Neutral conductor 13, 23

P

Package contents 25

Pairing 19

PE connection 13, 23

PE terminal 23

PLC 10, 13

Powerline 10

R

Reboot 38

Reset button 13

Resetting a devolo Magic adapter 20

S

Safety instructions 22

Single-phase connection 13, 24

Symbol description 6

T

Terminals 13, 23

Three-phase connection 13, 23

U

UKCA 9

W

Warranty 40