

VICTROLA™

Record Storage Case

Model: VSC-20



Instruction Manual

PLEASE READ THIS INSTRUCTION MANUAL CAREFULLY BEFORE USE
AND KEEP IT FOR FUTURE REFERENCE.

CONTENTS

SAFETY INSTRUCTIONS	2
RECORD STORAGE LAYOUT	2
RECORD STORAGE OPERATION	2
WARRANTY	3

SAFETY INSTRUCTIONS

1. Read these instructions – All the safety and operating instructions should be read before this product is operated.
2. Keep these instructions – The safety and operating instructions should be retained for future reference.
3. Do not use this apparatus near water – The appliance should not be used near water or moisture – for example, in a wet basement, near a swimming pool, or near other wet areas.
4. Clean only with a dry cloth.
5. Only use attachments/accessories specified by the manufacturer.
6. Please keep the unit in a well ventilated environment.
7. Only use attachments/accessories specified or provided by the manufacturer.
8. This product is not intended for commercial use. Household Use Only.

RECORD STORAGE LAYOUT

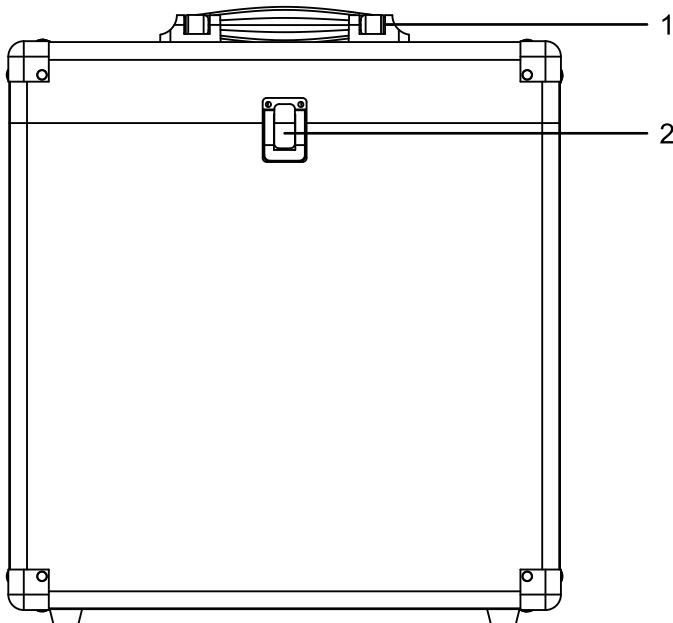

1. HANDLE
2. BUCKLE

RECORD STORAGE OPERATION

BASIC OPERATION

1. Lift the BUCKLE on the front of the turntable and open the lid.
2. Put the Vinyl Record into the Storage Case.
3. Holds about 30 Vinyl Records (depending on the thickness of Vinyl Record Sleeves).

NOTE:

- Storage Case can hold up to 13 lbs (6 kgs).
- Vinyl Records and Vinyl Record Sleeves are NOT included - Storage Case ONLY.

WARRANTY

Victrola is a registered trademark of Innovative Technology Electronics LLC.

Innovative Technology Electronics LLC.

Limited Warranty: 90 Days Labor, One Year Parts

Innovative Technology Electronics LLC. (IT) warrants the product to be free from “Defects” in materials under normal use for a period of “One Year” from the date of the original purchase. The Warranty is “Not” transferable. IT agrees, within the initial “90 Day” period, to repair or replace the product if it is determined to be defective at “No Charge”. It is further agreed that IT will cover the cost to repair or replace damaged “Parts” only for a total period of “One Year” from the date of the original purchase. The warranty does not cover cosmetic damage, antennas, AC cords, cabinets, headbands, ear-pads, or damage due to line power surges, connection to improper voltage supply or settings, misuse, mishandling, accident, acts of God or attempted repair by an unauthorized service agent.

To obtain service, the purchaser MUST present an original sales receipt / proof of purchase. Please contact us at www.victrola.com to request an RMA (Return Material Authorization) number to return products for service or replacement. Returns without an RMA number on the package will be refused and returned to sender. Upon receipt of the returning item and our full inspection (IT) may issue a replacement to customer for the same item or of one that has equivalent value and features. To return an item, supply full name, return address, phone number, item purchased, receipt of purchase and reason for return to obtain RMA number.

All returns must be in the original packaging or reasonable substitute to prevent damage. Customer “Must” include full name, shipping address and telephone number inside of package. No return will be shipped back to a PO Box or APO address.

Please include your check or money order in the amount of:

- **USD \$5.00 for items \$10.00 to \$39.99. (Price Paid Per Unit)**
- **USD \$10.00 for items \$40.00 to \$99.99. (Price Paid Per Unit)**
- **USD \$16.00 for items \$100.00 and up. (Price Paid Per Unit)**
- **Shipping fees are non-refundable**

to be payable to Innovative Technology Electronics LLC. (for handling and return shipping charges) (IT) will not be responsible for delays or unprocessed claims resulting from a purchaser’s failure to provide any / all of the necessary information. Send all inquiries or RMA request via our website **www.victrola.com/pages/technical-support**.

Innovative Technology Electronics LLC.

1 Channel Drive

Port Washington, NY 11050

Toll free: 1-877-483-2497

Website for support: www.victrola.com/pages/technical-support

There are no express warranties except as listed above.

REPAIR OR REPLACEMENT AS PROVIDED UNDER THIS WARRANTY IS THE EXCLUSIVE REMEDY OF THE CUSTOMER, (IT) SHALL NOT BE LIABLE FOR ANY INCIDENTAL OR CONSEQUENTIAL DAMAGES FOR BREACH OF ANY EXPRESS OR IMPLIED WARRANTY ON THIS PRODUCT EXCEPT TO THE EXTENT PROHIBITED BY APPLICABLE LAW. ANY IMPLIED WARRANTY OF MERCHANTABILITY OR FITNESS FOR A PARTICULAR PURPOSE ON THIS PRODUCT IS LIMITED IN DURATION TO THE DURATION OF THIS WARRANTY.

Some states do not allow the exclusion or limitation of incidental or consequential damages, or limitations on how long an implied warranty lasts, so the above exclusions or limitations may not apply to you. This warranty gives you specific legal rights and you may also have other rights, which vary from state to state.

Made In China.