

MOD-FPSKIT100(-B)  
MOD-FPSKIT150(-B)



VESA® Pattern  
600 x 400mm



Max load  
132lb (60kg)  
per display  
264lb (120kg)  
total

# Modular Series Ceiling Kit

FOR UP TO 75" DISPLAYS

The Peerless-AV® Modular Mount Series includes a small and easily manageable number of components to fulfill a vast majority of end-user requirements. Designed around a 2" (50mm) diameter Extension Pole, the line is ideal for new projects as well as for upgrading existing installations. As part of the Peerless-AV Modular Series, the MOD-FPSKIT100/150 includes all components required to ceiling mount your flat panel display. This kit can be expanded with additional Modular accessories to accommodate additional displays or allow you to create alternative configurations to achieve the perfect custom mounting solution.

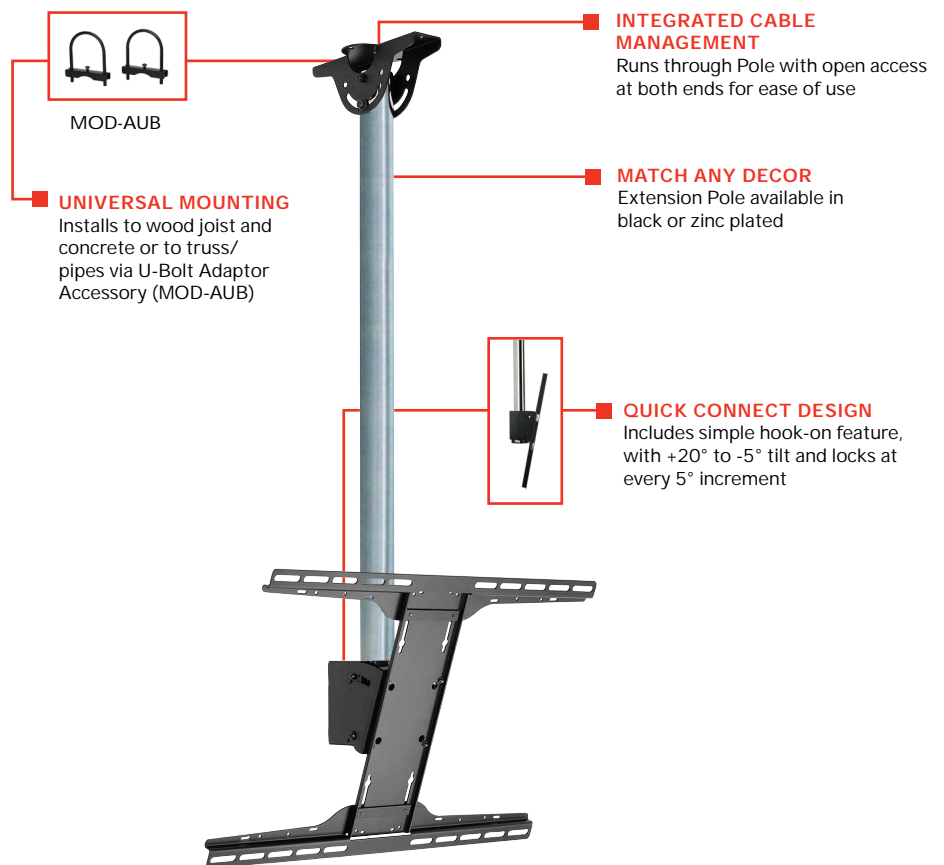

- Kit includes:  
Cathedral Ceiling Plate  
39" (1m) or 59" (1.5m) zinc plated or black Extension Pole  
Single Display Flat Panel Mount  
Large Universal Adaptor
- Cathedral Ceiling Plate can be angled  $\pm 60^\circ$  for use with vaulted or sloping ceilings
- Easy, one person display installation with up to a 39" (1m) or 59" (1.5m) drop
- Universal Display Adaptor for up to 75" displays with VESA® mounting patterns up to 600 x 400mm



Tilt Bracket

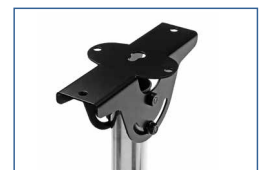

Ceiling Plate Cathedral Accessory, MOD-CPC



## Model Number

**WARRANTY: Limited 5-year**

MOD-FPSKIT100(-B)	Modular Series Ceiling Kit for up to 75" Displays; 39" (1m) height
MOD-FPSKIT150(-B)	Modular Series Ceiling Kit for up to 75" Displays; 59" (1.5m) height

## Product Specifications

	DIMENSIONS (W X H X D)	PRODUCT WEIGHT	LOAD CAPACITY	FINISH	AVAILABLE COLORS
MOD-FPSKIT100(-B)	24.38" x 442.85" x 8.86" (619 x 1088 x 225mm)	13.8lb (6.3kg)	132lb (60kg) per display 264lb (112kg) total	Powder Coat	MOD-FPSKIT100/150: Black/zinc plated
MOD-FPSKIT150(-B)	24.38" x 65.84" x 8.86" (619 x 1672 x 225mm)	16.3lb (7.4kg)			MOD-FPSKIT100-B/150-B: Black

## Package Specifications

	PACKAGE SIZE (W x H x D)	PACKAGE SHIP WEIGHT	PACKAGE UPC CODE	PACKAGE CONTENTS	UNITS IN PACKAGE
MOD-FPSKIT100(-B)	41.13" x 11.50" x 4.44" (1045 x 292 x 112mm)	17lb (7.7kg)	MOD-FPSKIT100: 735029282433 MOD-FPSKIT100-B: 735029290124	- MOD-CPC Cathedral Ceiling Plate - MOD-P100 3' (1.0m) Extension Pole or MOD-P150 5' (1.5m) Extension Pole	1
MOD-FPSKIT150(-B)	62.50" x 12.00" x 5.00" (1588 x 305 x 127mm)	19.5lb (8.8kg)	MOD-FPSKIT150: 735029269816 MOD-FPSKIT150-B: 735029290131	- MOD-FPMS Single Screen Mount - MOD-UNL Large Universal Adaptor	

## Accessories

<b>MOD-ACF(-W):</b> Accessory Cover for MOD-CPF Ceiling Plate	<b>MOD-CPC(-W):</b> Ceiling Plate, Cathedral	<b>MOD-P150(-B):</b> 50mm Extension Pole - 59" (1.5m)
<b>MOD-ADF:</b> Accessory Drill Fixture for 50mm Pole	<b>MOD-CPF:</b> Square Ceiling Plate, Flat (7.4" x 6.8")	<b>MOD-P200(-B):</b> 50mm Extension Pole - 78" (2.0m)
<b>MOD-APC:</b> Accessory Pole Coupler	<b>MOD-CPI:</b> I-Beam Ceiling Plate, Flat	<b>MOD-P300(-B):</b> 50mm Extension Pole - 118" (3.0m)
<b>MOD-ASC:</b> Accessory Screen-Stacking Clamp	<b>MOD-FPMD:</b> Flat Panel Mount, Dual Back-To-Back	<b>MOD-UNL:</b> Universal Screen Adaptor, Large
<b>MOD-ATD-W:</b> Accessory Trim Disc	<b>MOD-FPMS(-W):</b> Flat Panel Mount, Single	<b>MOD-UNM:</b> Universal Screen Adaptor, Medium
<b>MOD-AUB:</b> Accessory U-Bolt Adaptor	<b>MOD-P100(-B):</b> 50mm Extension Pole - 39" (1.0m)	

All dimensions = inch (mm)

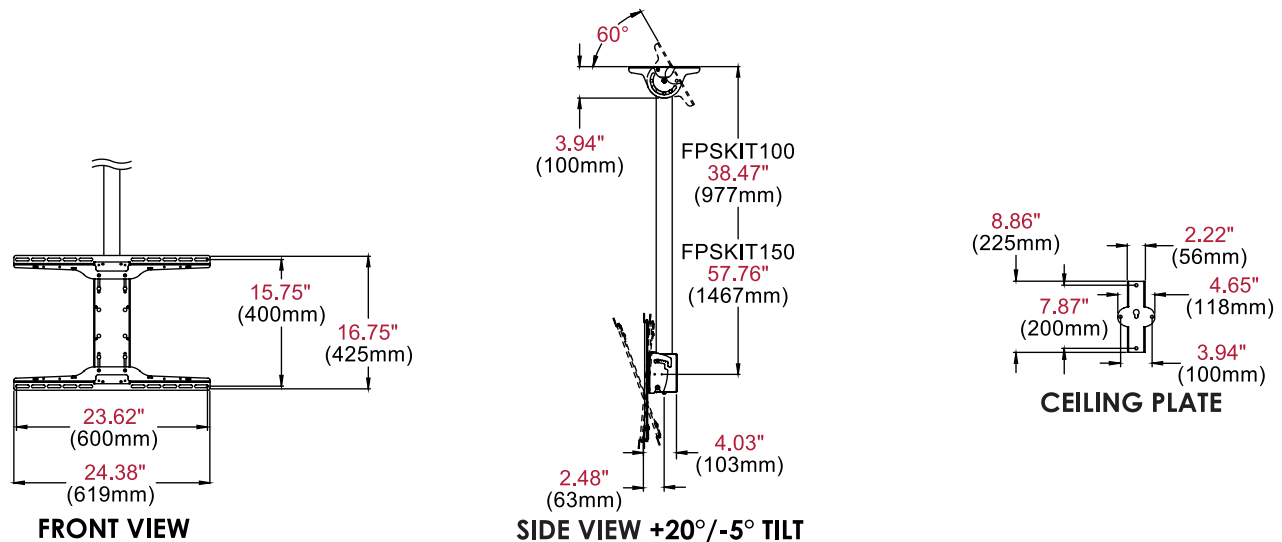

## Architect Specifications

The Modular Series Ceiling Kit shall be a Peerless-AV model MOD-FPSKIT150(-B)/100(-B) and shall be located where indicated on the plans. Assembly and installation shall be done according to instructions provided by the manufacturer.

Visit [peerless-av.com](http://peerless-av.com) to see the complete line of AV solutions from Peerless-AV, including outdoor displays, wireless, kiosks, digital audio, display mounts, projector mounts, carts/stands, and a full assortment of accessories.

**Peerless-AV**  
2300 White Oak Circle  
Aurora, IL 60502 USA  
**(800) 865-2112**  
**(630) 375-5100**  
**Fax: (800) 359-6500**

**Peerless-AV EMEA**  
Unit 3 Watford Interchange  
Colonial Way, Watford  
Herts, WD24 4WP  
United Kingdom  
**+44 (0) 1923 200100**  
**Fax: +44 (0) 1923 200101**

**Peerless-AV Latin America**  
Ave de las Industrias 413  
Parque Industrial Escobedo  
Escobedo, N.L.,  
Mexico 66062  
**+52 (81) 8384-8300**  
**Fax: +52 (81) 8384-8360**

**peerless-AV**<sup>®</sup>  
Driving Technology Through Innovation