

PLCM-UNL  
PLCM-UNL-CP



**Mounting Pattern**  
Up to 600 x 400mm  
(23.62" x 15.75")



**Max load**  
150lb  
(68.2kg)

**SMARTMOUNT.**

# Universal Ceiling Mounts

FOR 32" TO 90" DISPLAYS

The SmartMount® PLCM-UNL(-CP) Universal Ceiling Mounts utilize 1.5" NPT extension pipes for versatility, support, and connection. The 1.5" NPT threaded pipes make it simple to customize each mount to your specific application. The PLCM-UNL kit combines the PLP-UNL Universal I-Shaped Adaptor plate, the PLCM-2 tilt box, and the EXT103 extended length 1.5" NPT column, to deliver a drop of 36" for display mounting patterns of up to 600 x 400mm. When combined with a Peerless-AV® ceiling plate, it provides the perfect combination for flat panel ceiling mounting in sports facilities, airports, lobbies, or retail environments.

- -5° to 20° adjustable tilt and 360° swivel
- Peerless-AV EXT103 Aluminum Extension Column included, providing a 36" drop
- Simple hook-on display installation
- Universal I-Shaped Adaptor fits displays with mounting holes up to 600 x 400mm
- Landscape or portrait orientation
- Integrated cable management protects, contains and conceals cables for a clean, professional installation

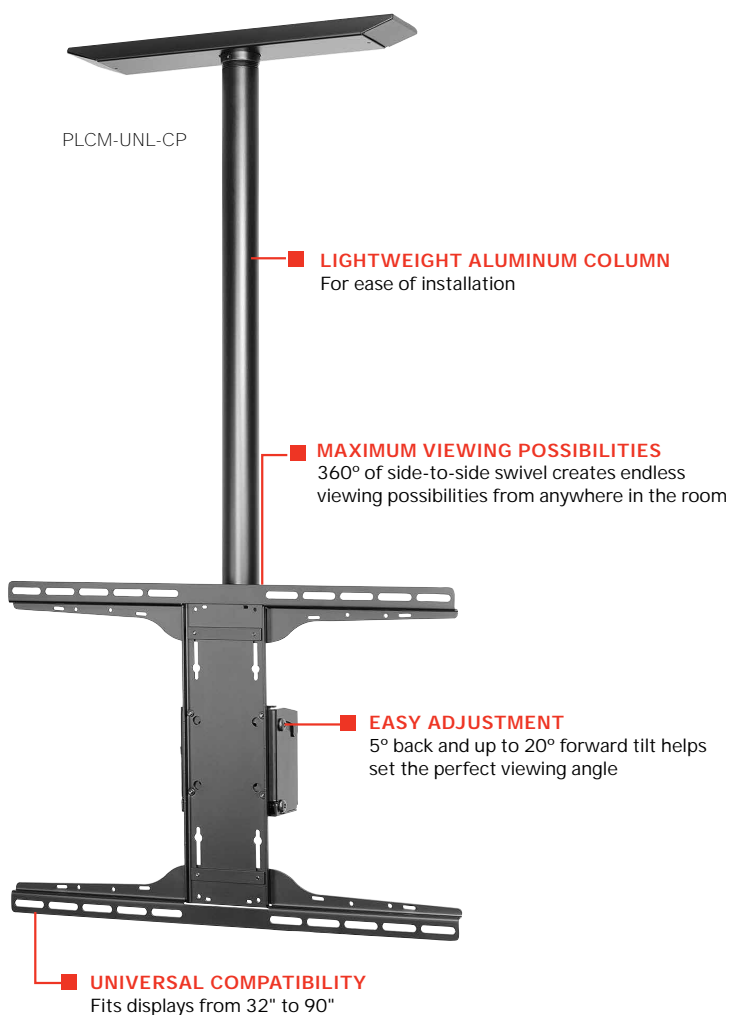

**RoHS**  
2002/95/EC

✉ info@peerless-av.com

🌐 peerless-av.com

**peerless-AV®**  
Driving Technology Through Innovation

PLCM-UNL/PLCM-UNL-CP SmartMount® Universal Ceiling Mount for 32" to 90" Displays

**Product Specifications**

	DIMENSIONS (W x H x D)	PRODUCT WEIGHT	LOAD CAPACITY	FINISH	AVAILABLE COLORS
PLCM-UNL	24.38" x 43.23" x 4.03" (619 x 1098 x 103mm)	22.8lb (10.3kg)	150lb (68.2kg)	Powder Coat	Black
PLCM-UNL-CP	24.38" x 44.23" x 4.03" (619 x 1123 x 103mm)	25.6lb (11.6kg)			

**Package Specifications**

	PACKAGE SIZE (W x H x D)	PACKAGE SHIP WEIGHT	PACKAGE UPC CODE	PACKAGE CONTENTS	UNITS IN PACKAGE
PLCM-UNL	46.25" x 7.75" x 3.63" (1175 x 197 x 92mm)	29.6lb (13.4kg)	735029241713	EXT103 Extension column, PLCM-2 tilt box, PLP-UNL Universal I-Shaped Adaptor, mounting hardware & instructions	1
PLCM-UNL-CP	46.25" x 7.75" x 3.63" (1175 x 197 x 92mm)	31.7lb (14.4kg)	735029241720	CMJ470 Ceiling plate, EXT103 extension column, PLCM-2 tilt box, PLP-UNL Universal I-Shaped Adaptor, mounting hardware & instructions	

**Accessories**

ACC, CMJ, DCS, DCT Models: Ceiling Plates

**PLCM-UNL-CP**

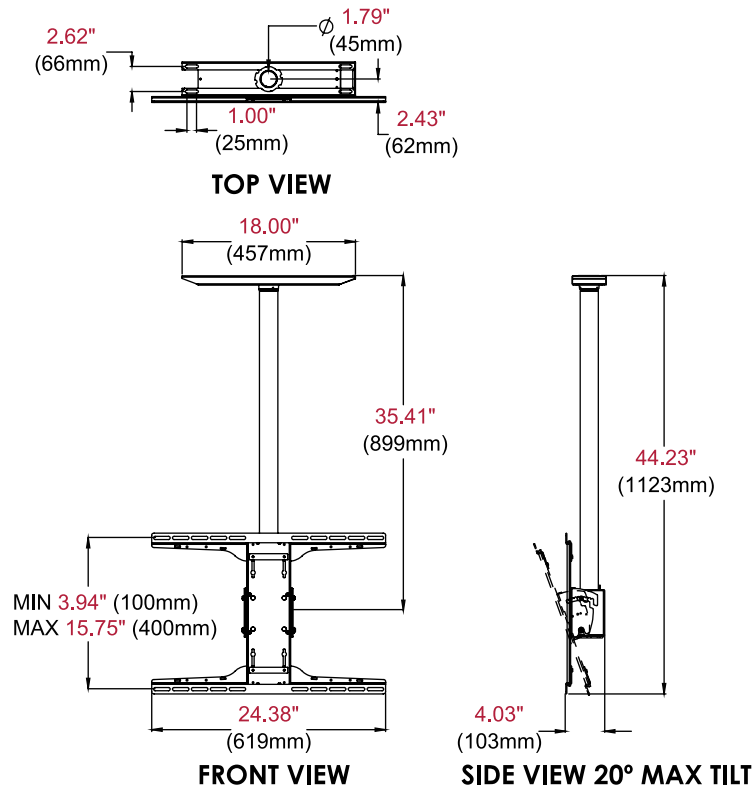

**PLCM-UNL**

All dimensions = inch (mm)

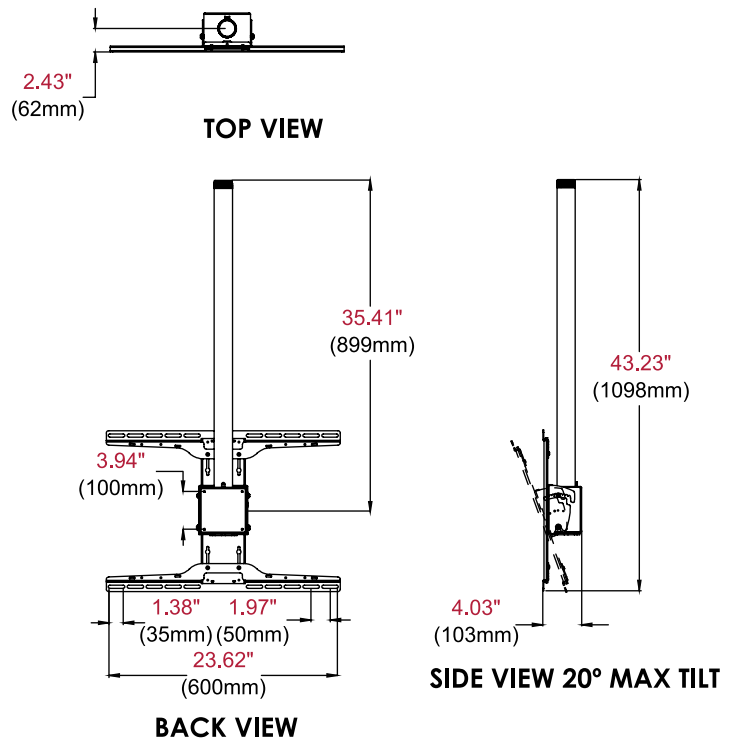

**Architect Specifications**

The Smartmount® Universal Ceiling Mount shall be a Peerless-AV model PLCM-UNL or PLCM-UNL-CP and shall be located where indicated on the plans. Assembly and installation shall be done according to instructions provided by the manufacturer.

Visit [peerless-av.com](http://peerless-av.com) to see the complete line of AV solutions from Peerless-AV, including outdoor displays, wireless, kiosks, digital audio, display mounts, projector mounts, carts/stands, and a full assortment of accessories.

**Peerless-AV**  
2300 White Oak Circle  
Aurora, IL 60502 USA  
  
(800) 865-2112  
(630) 375-5100  
Fax: (800) 359-6500

**Peerless-AV EMEA**  
Unit 3 Watford Interchange  
Colonial Way, Watford  
Herts, WD24 4WP  
United Kingdom  
+44 (0) 1923 200100  
Fax: +44 (0) 1923 200101

**Peerless-AV Latin America**  
Ave de las Industrias 413  
Parque Industrial Escobedo  
Escobedo, N.L.,  
Mexico 66062  
+52 (81) 8384-8300  
Fax: +52 (81) 8384-8360

