

DESONO™ CM60DTD

TWO-WAY 6.5-INCH
CEILING LOUDSPEAKER



FEATURES

- Zoom Certified
- Requires only 6.2" (157 mm) mounting depth
- High speech intelligibility coupled with full-range music reproduction
- Thin-edge, magnetically attached grille
- Tap switch allows for 70V/100V or 16Ω low impedance operation
- Tuned bass reflex port for optimized low frequency performance
- Loudspeaker overload protection for 24/7 failsafe operation
- ETL listed to conform with UL Std 1480A and UL 2043; Certified to CSA C22.2#62368-1

APPLICATIONS

Conference Rooms · Hallways ·
Training Rooms · Multipurpose Rooms ·
Lunch Rooms · Manufacturing Areas ·
Offices · Waiting Rooms

DESCRIPTION

The Desono CM60DTD two-way 6.5" ceiling loudspeaker delivers crystal clear audio for all your public address and background music needs. Its 6.5" coated paper woofer and 1" tweeter results in a high SPL and extremely low distortion, ensuring exceptional clarity over the entire frequency spectrum.

The CM60DTD utilizes a 5-position switchable transformer ranging from 3.75W to 60W with low-impedance bypass for constant-voltage operation, making it an excellent choice for large areas of BGM.

Designed with the installer in mind, they can be blind-mounted from below the ceiling, and feature a magnetic grille for easy toolless installation and removal that can also be painted to match the room decor. Additionally, the tap switch is located on the face of the loudspeaker, so adjustments can be made without requiring ceiling access.

Desono CM60DTD loudspeakers are an ideal choice for a multitude of environments that demand superior speech intelligibility and full range music reproduction.

TECHNICAL SPECIFICATIONS

Operating Mode	Passive	
Operating Environment	Indoor	
Operating Range (-10dB)	75 Hz to 22 kHz	
Nominal Beamwidth (H x V)	150° conical	
Transducers	LF 1 x 6.5" (165 mm) coated paper cone HF 1 x 1" (25 mm) soft dome	
Continuous Power Handling @ Nominal Impedance	31V	60W @ 16Ω (240W peak)
Nominal Sensitivity @ 1m	@ 1W	@ 2.83V
	86 dB	83 dB
Nominal Maximum SPL @ 1m	Peak	Continuous
	110 dB	104 dB
Transformer	70V: 60W, 30W, 15W, 7.5W, 3.75W 100V: 60W, 30W, 15W, 7.5W	
Protection	3-step self-resetting protection	
Recommended Amplifiers	60W - 120W @ 16Ω (31V - 44V)	

PHYSICAL

Input Connection	(1) 4-way Euroblock connector with permanent pass-through
Mounting Provisions	2 mounting clamps with grip range of 0.2" - 2.6" (3 - 65 mm); Cover plate with 0.75" (22 mm) NPT knockout for conduit connectors
Safety Features	2 hang points
Compliance	ETL listed to comply with UL 1480A and UL 2043; Certified to CSA C22.2#62368-1; Suitable for use in air handling spaces per NFPA 70, NFPA 90 Conforms with City of Chicago Codes
Dimensions H x Dia.	6.2" x 10.2" (157 mm x 258 mm)
Cutout Diameter	9.1" (232 mm)
Weight	8.8 lbs (4.0 kg)
Finish	Refer to the Technical Drawings (page 3)
Accessories (included)	Tile rails; tile rail spacers; cutout template

OPTIONS

Accessories	SQGR square grille
-------------	--------------------

Biamp strives to improve its products on a continual basis. Specifications are therefore subject to change without notice. Data presented on this spec sheet represents the basic performance specifications for the model. For a detailed analysis of this loudspeaker's performance, please download the GLL file from our website: [biamp.com](http://www.biamp.com)

DESONO CM60DTD

TWO-WAY 6.5-INCH
CEILING LOUDSPEAKER

FREQUENCY RESPONSE (dB SPL)

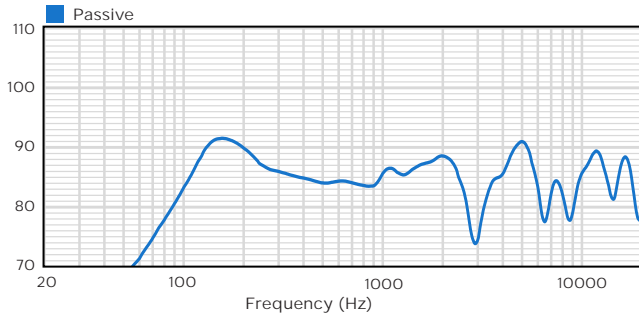

VERTICAL OFF-AXIS DOWN RESPONSE (dB)

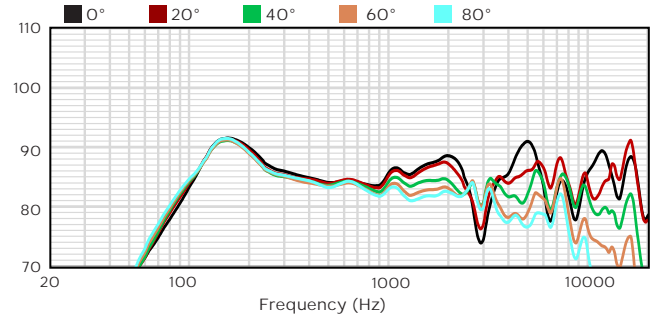

IMPEDANCE (Ohms)

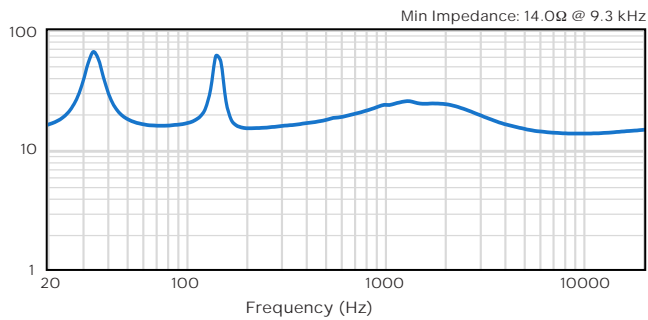

BEAMWIDTH (Degrees)

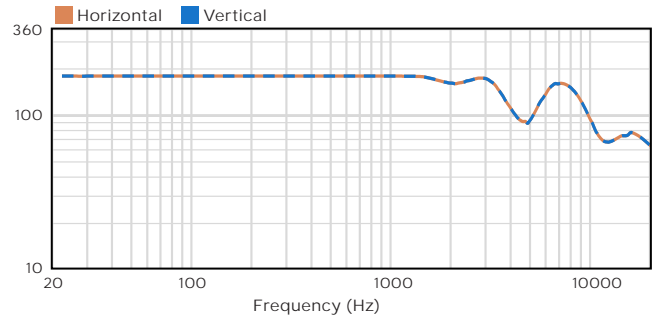

DESONO CM60DTD

TWO-WAY 6.5-INCH
CEILING LOUDSPEAKER

TECHNICAL DRAWING / DIMENSIONS / FINISH

H x W (diameter)
6.2" x 10.2"
(157 mm x 258 mm)

Unit Weight
8.8 lbs (4.0 kg)

Shipping Weight
11.6 lbs (5.3 kg)

Grille:
Steel, White (RAL 9010) finish

Enclosure / Finish
Steel, matte finish

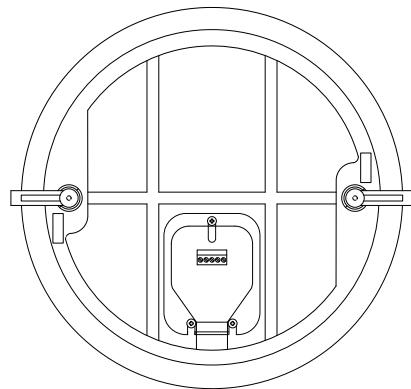
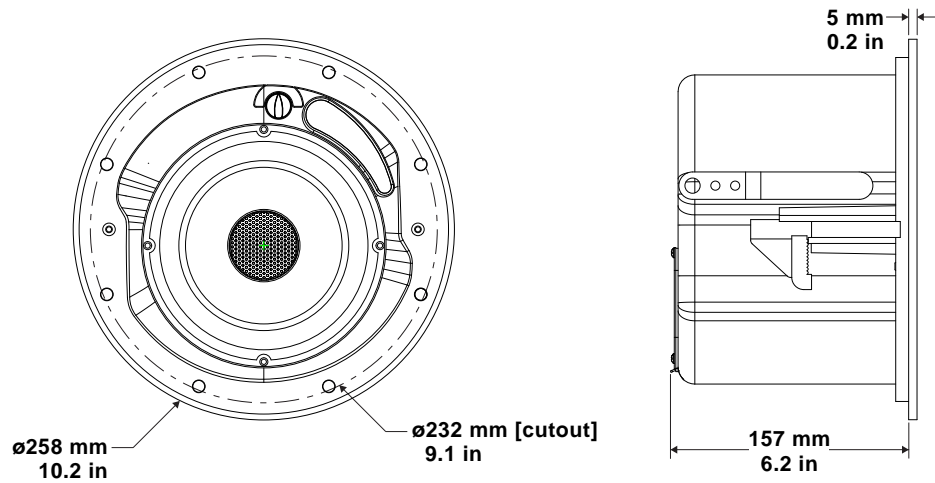

TILE BRIDGE AND RAILS

