

# DATA SHEET

## DESONO E Series

# ENT206

## TWO-WAY, COMPACT COLUMN POINT SOURCE LOUDSPEAKER

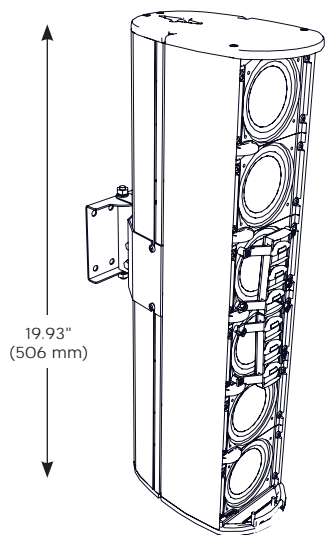

Shown with grille *o*

### APPLICATIONS

Houses of worship · Bars and restaurants · Conference rooms · Court rooms · Auditoria · Theaters · Museums · Airports · Train stations · Stadium concourses · Multipurpose outdoor and indoor venues · Delay fill in larger venues

### DESCRIPTION

Available in four sizes, the Desono™ ENT200 models have been expertly engineered to serve the wide range of applications routinely encountered by professional sound contractors. Possessing advanced features, highly-focused dispersion patterns, weather-resistant construction, and most importantly sonic excellence, ENT200 columns make installations not only fast and simple, but as functionally effective as possible.

Double the height of the smaller ENT203, the ENT206 provides directional control at significantly lower frequencies than the ENT203, along with enough power to effectively cover much larger areas while still remaining unobtrusive. The ENT206 employs six high-power LF cone drivers and two CRE (Compact Ribbon Emulator) HF tweeter arrays in a two-way, single-amped configuration.

Ideally suited to applications such as music and speech reinforcement for reverberant houses of worship, hotel lobbies, assembly rooms, transit stations, indoor/outdoor swimming pools, outdoor smoking areas, bowling alleys, and much more, the ENT206 is a solid performer that belies its small size. Like the ENT203, the ENT206 also can be utilized to support larger systems for delay and area fill.

### FEATURES

- Zoom Certified
- Advanced passive crossover technology and dynamic protection circuitry
- Compact Ribbon Emulator high frequency technology for narrow, well-behaved directivity control
- All-weather construction for indoor/outdoor use
- Simple installation using the included pan-tilt mounting bracket
- Selectable low impedance or 70V/100V operation



### TECHNICAL SPECIFICATIONS<sup>1</sup>

Operating Mode	Passive		
Operating Environment	Indoor or outdoor		
Operating Range <sup>2</sup>	120 Hz to 22 kHz		
Nominal Beamwidth (H x V)	140° x 20°		
Transducers	LF 6 x 80 mm long excursion mylar driver HF 2 x 3-element Compact Ribbon Emulator		
Continuous Power Handling <sup>3</sup> @ Nominal Impedance	Passive	35 V	150 W @ 8 Ω (600 W peak)
	Autoformer	70 V 60 W 30 W 15 W 7.5 W 3.75 W	100 V 60 W 30 W 15 W 7.5 W
Nominal Sensitivity <sup>4</sup>	Passive	@ 1 W 94 dB	@ 2.83 V 94 dB
Nominal Maximum SPL <sup>5</sup> (Whole Space)	Passive	Peak 122 dB	Continuous 116 dB
Equalized Sensitivity <sup>6</sup>	System	@ 1 W 93 dB	@ 2.83 V 93 dB
Equalized Maximum SPL <sup>7</sup>	System	Peak 121 dB	Continuous 115 dB
Required Accessories	External High Pass Filter - 120 Hz, 24 dB /octave Digital Signal Processor		
Recommended Amplifiers	Passive	150 W - 300 W @ 8 Ω (35 V - 49 V)	

### PHYSICAL

Input Connection	NL4-type connector for low impedance operation, and 8-position terminal strip for low impedance or constant voltage operation
Mounting Points	Small pan-tilt mounting bracket included (14° down-tilt, ± 55° panning)
Environmental	IP54 per IEC 60529, designed in accordance with MIL-STD-810G Included ABS plastic rain cover with integrated cable inlet and 1" (25.4mm) knockout for conduit ingress
Dimensions H x W x D	19.93" x 4.63" x 7.48" (506 mm x 118 mm x 190 mm)
Weight	15 lbs (6.8 kg)
Finish	Refer to the Technical Drawing (page 3)

### OPTIONS

Accessories	E200-UMK universal mounting kit E200-SAK stand adapter kit
-------------	---

# DESONO E Series

## ENT206 TWO-WAY, COMPACT COLUMN POINT SOURCE LOUDSPEAKER

### AXIAL PROCESSED RESPONSE (dB)<sup>8</sup>

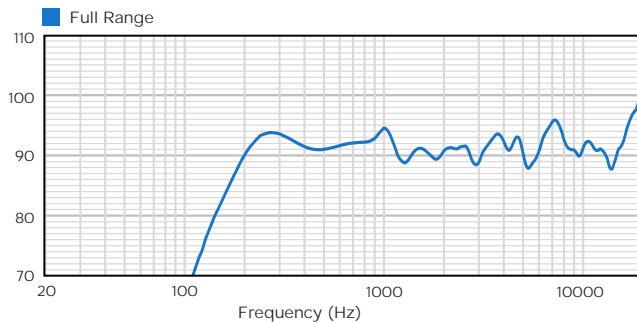

### BEAMWIDTH (Degrees)<sup>11</sup>

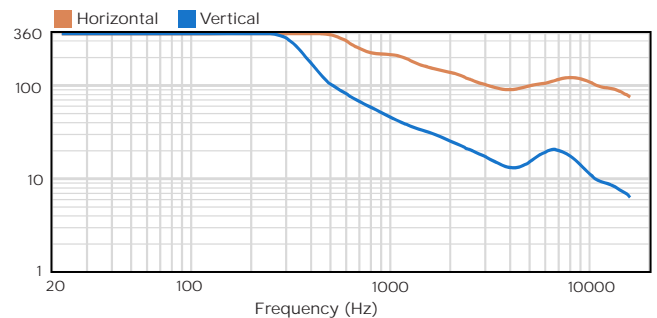

### AXIAL SENSITIVITY (dB SPL)<sup>9</sup>

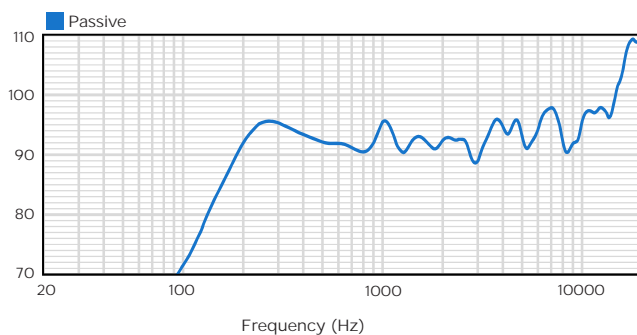

### DIRECTIVITY INDEX (dB)<sup>10</sup>

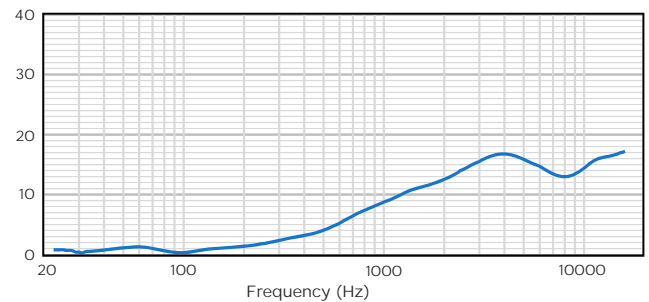

### IMPEDANCE (Ohms)

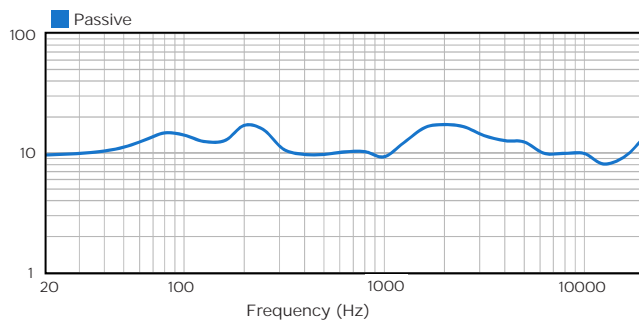

Minimum Impedance: 8.1  $\Omega$  @ 12500 Hz

### ARCHITECTURAL SPECIFICATIONS

The loudspeaker system shall be a two-way, full-range column array system with six 80mm long excursion mylar low frequency transducers and two three-element Compact Ribbon Emulator direct-radiating high frequency transducers. The drivers shall be connected to an integral crossover with an HF crossover frequency of 5000 Hz, and dynamic driver protection circuitry. There shall be one eight-terminal barrier strip, and an NL4-type connector on a recessed input panel. The system shall be equipped with a 60W high performance autoformer for use in 70.7V or 100V distributed audio systems, with 60W, 30W, 15W, 7.5W and 3.75W taps available in 70.7V distributed systems (60W, 30W, 15W and 7.5W taps available in 100V distributed systems). The paintable enclosure shall be constructed of high-gloss PVC. The front of the enclosure shall be fitted with a powder-coated perforated marine-grade aluminum grille backed with foam or fabric. A pan-tilt mounting bracket is included that will allow the system to have a down-tilt of up to 22.5° and a panning angle of +/- 55°. The system shall have an operating range of 120 Hz to 22 kHz (-10 dB) and a low impedance (8 $\Omega$ ) input capability of 35V RMS. The sensitivity on-axis at one meter with a power input of 1 watt shall be 94 dB. The nominal dispersion shall be 140° H x 20° V. Dimensions shall be 19.93 inches (506 mm) high, 4.63 inches (118 mm) wide and 7.48 inches (190 mm) deep, with a loudspeaker weight of 15 lbs (6.8 kg). The loudspeaker system shall be a Desono ENT206.

# DESONO E Series

## ENT206 TWO-WAY, COMPACT COLUMN POINT SOURCE LOUDSPEAKER

### TECHNICAL DRAWING / DIMENSIONS / FINISH

**H x W x D**  
19.93" x 4.63" x 7.48"  
(506 mm x 118 mm x 190 mm)

**Unit Weight**  
15 lbs (6.8 kg) loudspeaker and mount

**Shipping Weight**  
18 lbs (8.2 kg)

**Grille:**  
Powder-coated perforated marine-grade aluminum backed with color-matched foam or fabric backing. Black (RAL#9004) or White (RAL#9003)

**Enclosure / Finish**  
Black or White high gloss extruded paintable PVC

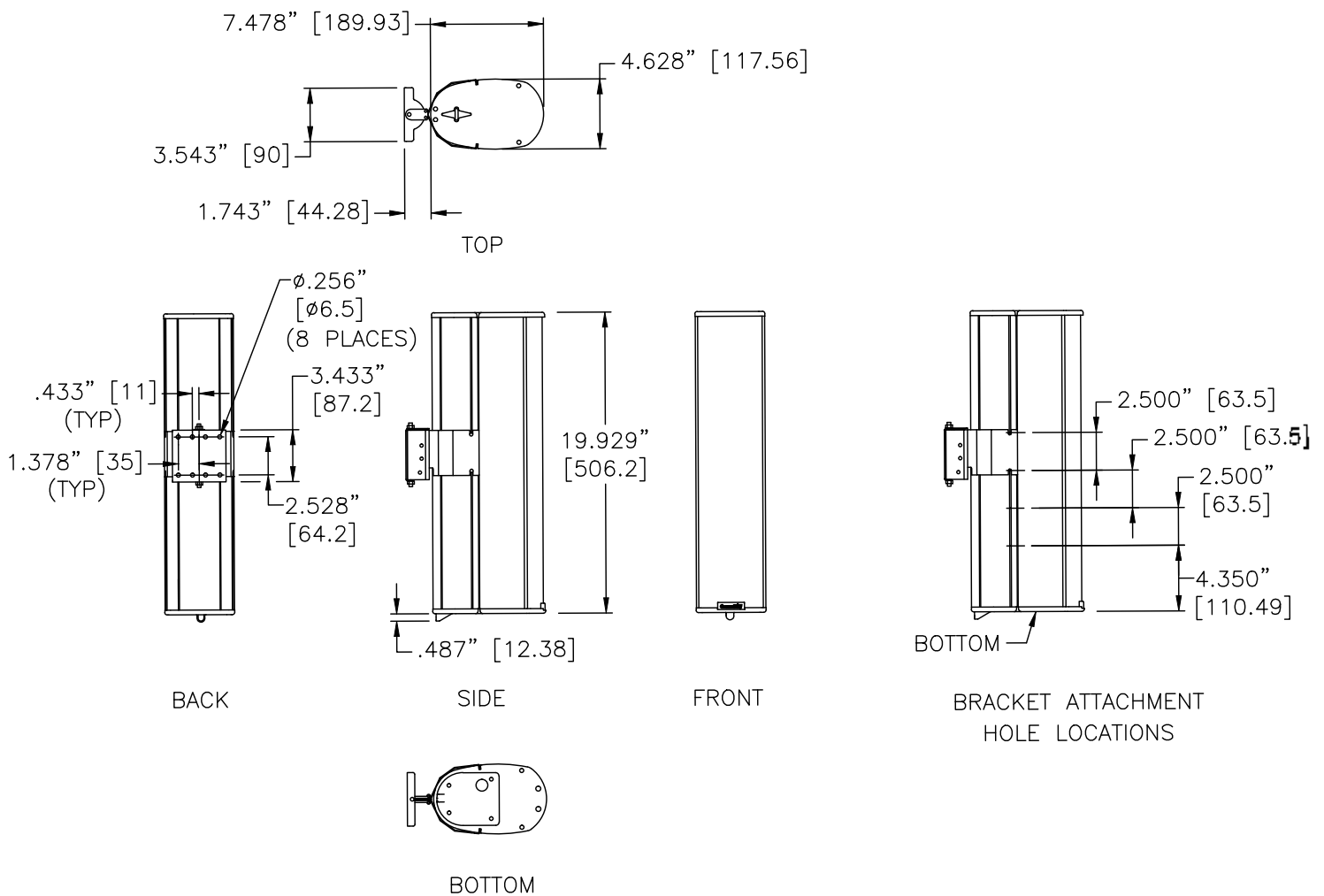

# DESONO E Series

# ENT206

TWO-WAY, COMPACT  
COLUMN POINT SOURCE LOUDSPEAKER

## CONNECTION DIAGRAMS

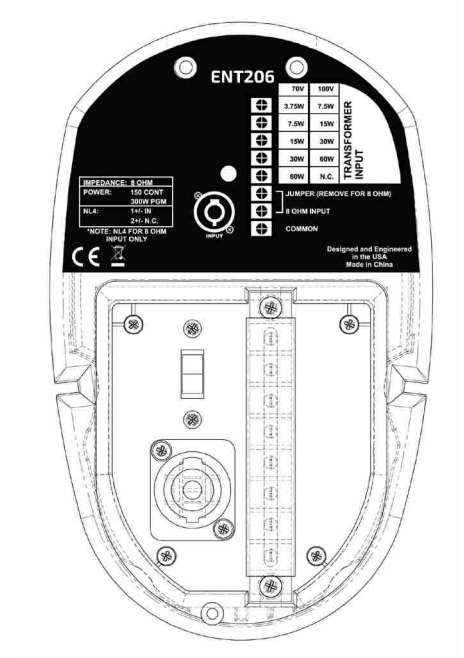
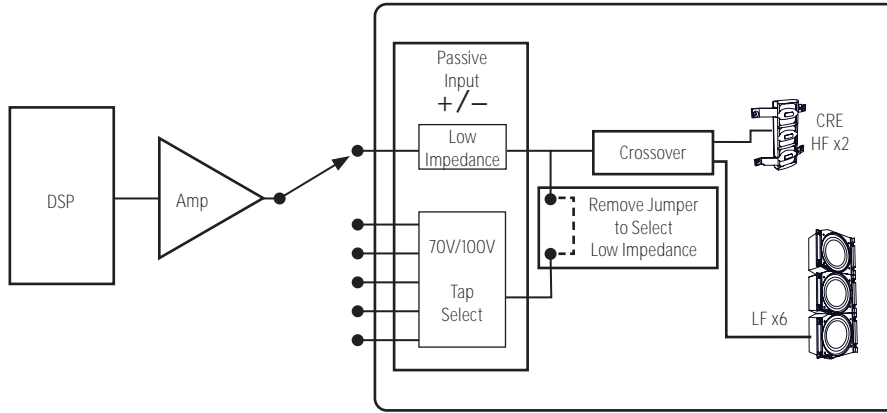

Input panel

## NOTES

- PERFORMANCE SPECIFICATIONS** All measurements are taken indoors using a time-windowed and processed signal to eliminate room effects, approximating an anechoic environment, a distance of 6.0 m. All acoustic specifications are rounded to the nearest whole number. An external DSP using settings provided by Biamp is required to achieve the specified performance; further performance gains can be realized using the FIR loudspeaker optimization presets available in Biamp's Community Amplified Loudspeaker Controllers (ALC SERIES).
- OPERATING RANGE** The frequency range in which the on-axis processed response remains within 10dB of the average SPL.
- CONTINUOUS POWER HANDLING** Maximum continuous input voltage (and the equivalent power rating, in watts, at the stated nominal impedance) that the system can withstand, without damage, for a period of 2 hours using an EIA-426-B defined spectrum; with recommended signal processing and protection filters.
- NOMINAL SENSITIVITY** Averaged SPL over the operating range with an input voltage that would produce 1 watt at the nominal impedance and the averaged SPL over the operating range with a fixed input voltage of 2.83V, respectively; swept sine wave axial measurements with no external processing applied in whole space, except where indicated.
- NOMINAL MAXIMUM SPL** Calculated based on nominal / peak power handling, respectively, and nominal sensitivity; exclusive of power compression.
- EQUALIZED SENSITIVITY** The respective SPL levels produced when an EIA-426-B signal is applied to the equalized loudspeaker system at a level which produces a total power of 1 watt, in sum, to the loudspeaker subsections and also at a level which produces a total voltage, in sum, of 2.83V to the loudspeaker subsections, respectively; each referenced to a distance of 1 meter.
- EQUALIZED MAXIMUM SPL** The SPL produced when an EIA-426-B signal is applied to the equalized loudspeaker system, at a level which drives at least one subsection to its rated continuous input voltage limit, referenced to a distance of 1 meter. The peak SPL represents the 2:1 (6dB) crest factor of the EIA-426-B test signal.
- AXIAL PROCESSED RESPONSE** The on-axis variation in acoustic output level with frequency of the complete loudspeaker system with recommended signal processing applied. 1/6 octave Gaussian smoothing applied.
- AXIAL SENSITIVITY** The on-axis variation in acoustic output level with frequency for a 1 watt swept sine wave, referenced to 1 meter with no signal processing. 1/6 octave Gaussian smoothing applied.
- DIRECTIVITY INDEX** The ratio of the on-axis SPL squared to the mean squared SPL at the same distance for all points within the measurement sphere for each given frequency; expressed in dB. 1/6 octave Gaussian smoothing applied.
- BEAMWIDTH** The angle between the -6dB points in the polar response of the loudspeaker when driven in the operating mode which utilizes the largest number of individually amplified pass bands. 1/6 octave Gaussian smoothing applied.

Data presented on this spec sheet represents a selection of the basic performance specifications for the model. These specifications are intended to allow the user to perform a fair, straightforward evaluation and comparison with other loudspeaker spec sheets. For a detailed analysis of this loudspeaker's performance, please download the GLL file and/or the CLF file from our website: [biamp.com](http://biamp.com)

**CAUTION:** Installation of loudspeakers should only be performed by trained and qualified personnel. It is strongly recommended that a licensed and certified professional structural engineer approve the mounting design.