

## 5-Port Gigabit Ethernet Industrial Unmanaged Switch - DIN Rail Mountable

### Product ID

I51G-ETHERNET-SWITCH

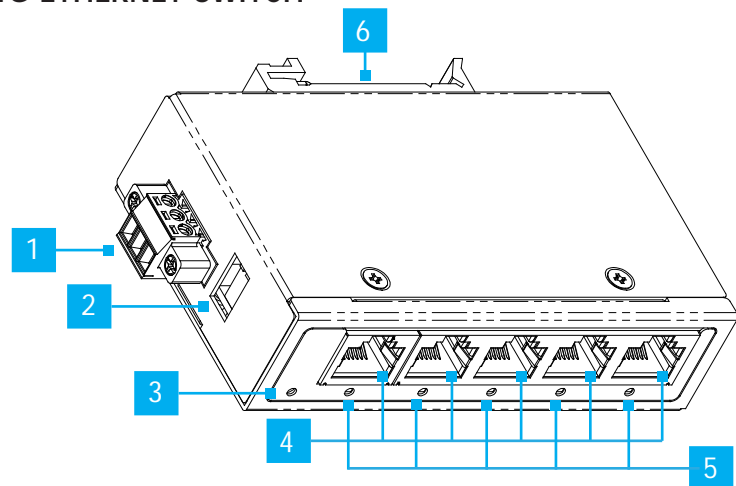

\*Product may vary from image

	Feature	Function
1	Terminal Block Connector	<ul style="list-style-type: none"> <li>Connect the <b>Gigabit Ethernet Industrial Unmanaged Switch</b> to a <b>DC Power Source</b></li> <li>Requires an input voltage of 9-60V DC</li> <li>A <b>Grounding Point</b> is available</li> </ul>
2	DIP Switches	<ul style="list-style-type: none"> <li><b>Enable</b> or <b>Disable</b> the <b>Broadcast Storm Protection (BSP)</b> and <b>Quality of Service (QoS)</b> features</li> </ul>
3	Power LED	<ul style="list-style-type: none"> <li>Indicates if the unit is receiving power</li> <li><b>Solid Green:</b> Power</li> <li><b>O :</b> No Power</li> </ul>
4	RJ45 Ethernet Ports	<ul style="list-style-type: none"> <li>Connects the unit and <b>Network Devices</b> to the <b>Local Network</b> via <b>Ethernet Cables</b></li> <li>Supports 10/100/1000Mbps</li> </ul>
5	Link/Activity LED Indicators	<ul style="list-style-type: none"> <li><b>Solid Green:</b> Active link</li> <li><b>Flashing Green:</b> Activity</li> </ul>
6	Mounting Holes (Not Shown)	<ul style="list-style-type: none"> <li>Located at the back of the unit</li> <li>Use to attach the <b>Mounting Ear Kit</b> or the <b>DIN Rail Bracket</b></li> </ul>

### Package Contents

- Gigabit Switch x 1
- 3-Pin Terminal Block x 1
- DIN Rail Mounting Kit x 1
- Mounting Ear Kit x 1
- Quick-Start Guide x 1

### Requirements

For the latest manuals, product information, technical specifications, and declarations of conformance, please visit: [www.StarTech.com/I51G-ETHERNET-SWITCH](http://www.StarTech.com/I51G-ETHERNET-SWITCH)

- Phillips head screwdriver
- Terminal block DC power supply: 9-60V DC

### Installation

#### DIP Switches

DIP Switch	ON	OFF
1 - BSP	<ul style="list-style-type: none"> <li>Broadcast Storm Protection (BSP) limits the rate of broadcast traffic after a 2,000 packet per second threshold is exceeded, additional packets outside of this threshold are dropped</li> </ul>	Disables <b>BSP</b> (Default)
2 - QoS	<ul style="list-style-type: none"> <li>Quality of Service (QoS) prioritizes tagged traffic (IEEE 802.1Q) to ensure that important data is transmitted efficiently with minimal delay, even during periods of high network congestion</li> </ul>	Disables <b>QoS</b> (Default)

1. Adjust the **DIP Switches** according to the needs of the setup.

**Note:** A power cycle is required after changing the DIP Switch settings for the changes to take effect.

2. Connect a **DC Power Source** to the **Terminal Block Connector**. Recommended power 9-60V DC.

**Warning!**

Verify the correct polarity before supplying power to prevent equipment damage. Ensure that the unit is properly grounded to ensure safe operation.

3. Plug in an **Ethernet Cable** between **Port 5** (Uplink) and the **Local Network**.
4. Connect **Network Devices** as needed to the remaining **RJ45 Ethernet ports** using **Ethernet Cables**.

## DIN Rail Mounting (Optional)

1. Mount the **Gigabit Ethernet Industrial Unmanaged Switch** by inserting the **DIN Rail Bracket** onto the **DIN Rail** at an angle, starting from the top then push against the **DIN Rail** (Figure 1).

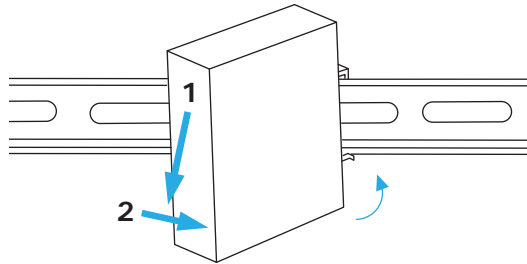

Figure 1

## Regulatory Compliance

### FCC Compliance Statement

This equipment has been tested and found to comply with the limits for a Class A digital device, pursuant to part 15 of the FCC Rules. These limits are designed to provide reasonable protection against harmful interference when the equipment is operated in a commercial environment. This equipment generates, uses, and can radiate radio frequency energy and, if not installed and used in accordance with the instruction manual, may cause harmful interference to radio communications. Operation of this equipment in a residential area is likely to cause harmful interference in which case the user will be required to correct the interference at his own expense.

Any changes or modifications not expressly approved by the party responsible for compliance could void the user's authority to operate the device. If shielded interface cables are included with the product, or if additional components or accessories are designated for use with the installation, they must be used to ensure compliance with FCC regulations.

### ISED Statement / Déclaration d'ISED

CAN ICES-003(A) / NMB-003(A)

This Class A digital apparatus complies with Canadian ICES-003.

This device complies with ISED Canada licence-exempt RSS standard(s). Operation is subject to the following two conditions: (1) this device may not cause interference, and (2) this device must accept any interference, including interference that may cause undesired operation of the device.

Cet appareil numérique de la classe A est conforme à la norme NMB-003 du Canada.

Le présent appareil est conforme aux CNR d'ISED Canada applicables aux appareils radio exempts de licence. L'exploitation est autorisée aux deux conditions suivantes : (1) l'appareil ne doit pas produire de brouillage, et (2) l'appareil doit accepter tout brouillage radioélectrique subi, même si le brouillage est susceptible d'en compromettre le fonctionnement.

### EU WEEE Directive

StarTech.com products must not be disposed of with household waste. StarTech.com products must be disposed of at an authorized electrical and electronic equipment recycling facility. By collecting and recycling waste, you help save natural resources and ensure that the product is disposed of in an environmentally friendly and healthy way.

### CE EMC/EMI

StarTech.com hereby declares that this device complies with the Electromagnetic Compatibility Directive (EMC).

A copy of the EU Declaration of Conformity is available at [www.startech.com](http://www.startech.com) under the Product Support tab.

[www.startech.com/I51G-ETHERNET-SWITCH](http://www.startech.com/I51G-ETHERNET-SWITCH)

## Surface Mounting (Optional)

1. Use a **Phillips Head Screwdriver** to **Remove the Screws** (x 2) that secure the **DIN Rail Bracket** to the back of the unit.
2. Align one of the **Mounting Ears** with the **Mounting Holes** at the back of the unit.
3. Insert the **Screws** (x 2) through the **Mounting Ear** and into the **Mounting Hole**. Use a **Phillips Head Screwdriver** to tighten the **Screws** (x 2).
4. Repeat **Steps 2 to 3** with the remaining **Mounting Ear**.
5. Use the **Mounting Ears Keyholes** as a mounting template to mark the location on the **Mounting Surface**.
6. Use **Screws** (x 2) (not supplied) to secure the unit onto the **Mounting Surface**.

### Safety Measures

**EN:** Do not touch the product under power if the product has an exposed printed circuit board or electrical wire.

**NL:** Raak het product niet aan als het onder stroom staat en er een blootliggende printplaat of elektrische draad zichtbaar is.

**FR:** Ne touchez pas le produit lorsqu'il est sous tension et qu'il dispose d'un circuit imprimé ou d'un électrique apparent.

**DE:** Berühren Sie das Produkt nicht unter Spannung, wenn es eine freiliegende Leiterplatte oder einen freiliegenden elektrischen Draht hat.

**IT:** Non toccare il prodotto quando è sotto tensione se il prodotto ha una scheda di circuito stampato o un lo elettrico esposto.

**ES:** No toque el producto cuando se encuentre bajo tensión si este tiene una placa de circuito impreso o un cable eléctrico expuesto.

**JP:** プリント基板や電線が露出している製品は、電源が入っている状態で直接触れないでください。

### Use of Trademarks, Registered Trademarks, and other Protected Names and Symbols

This manual may make reference to trademarks, registered trademarks, and other protected names and/or symbols of third-party companies not related in any way to StarTech.com. Where they occur these references are for illustrative purposes only and do not represent an endorsement of a product or service by StarTech.com, or an endorsement of the product(s) to which this manual applies by the third-party company in question. StarTech.com hereby acknowledges that all trademarks, registered trademarks, service marks, and other protected names and/or symbols contained in this manual and related documents are the property of their respective holders.

### Warranty Information

This product is backed by a two-year warranty.

For further information on product warranty terms and conditions, please refer to [www.startech.com/warranty](http://www.startech.com/warranty).

### Limitation of Liability

In no event shall the liability of StarTech.com Ltd. and StarTech.com USA LLP (or their officers, directors, employees or agents) for any damages (whether direct or indirect, special, punitive, incidental, consequential, or otherwise), loss of profits, loss of business, or any pecuniary loss, arising out of or related to the use of the product exceed the actual price paid for the product. Some states do not allow the exclusion or limitation of incidental or consequential damages. If such laws apply, the limitations or exclusions contained in this statement may not apply to you.

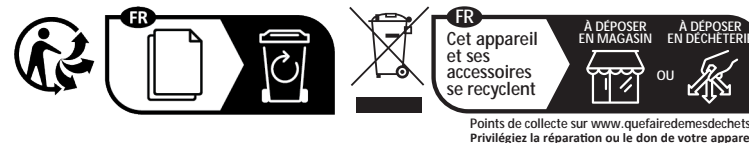

### StarTech.com Ltd.

45 Artisans Crescent  
London, Ontario  
N5V 5E9  
Canada

### StarTech.com LLP

4490 South Hamilton  
Road  
Groveport, Ohio  
43125  
U.S.A.

### StarTech.com Ltd.

Unit B, Pinnacle 15  
Gowerton Road  
Brackmills,  
Northampton  
NN4 7BW  
United Kingdom

### StarTech.com Ltd.

Siriusdreef 17-27  
2132 WT Hoofddorp  
The Netherlands

FR: [startech.com/fr](http://startech.com/fr)

DE: [startech.com/de](http://startech.com/de)

ES: [startech.com/es](http://startech.com/es)

NL: [startech.com/nl](http://startech.com/nl)

IT: [startech.com/it](http://startech.com/it)

JP: [startech.com/jp](http://startech.com/jp)