

EPT650



	<b>Mounting Pattern</b> Up to 732 x 405mm (28.84" x 15.94")	 <b>Max Load</b> 175lb (79kg)
--	---	--

# Outdoor Universal Tilt Wall Mount

FOR 32" TO 75" DISPLAYS

Peerless-AV's Outdoor Universal Tilt Wall Mount provides a sure way to mount flat panel displays outdoors with its corrosion resistant E-Coat finish and stainless steel hardware. In addition to simple installation with its Hook-and-Hang™ design, this mount offers tilt functionality while keeping the display a mere 2.64" (67mm) from the wall. Tamper-resistant hardware deters theft, offering peace-of-mind with every installation and for additional security, the mount has accommodations for optional padlocks.

- Made of corrosion resistant materials for weather resistance
- Universal mount fits displays with mounting patterns up to 732 x 405mm (28.84"W x 15.94"H) and up to 600 x 400mm VESA® compliant
- One-Touch™ tilt allows adjustment of +15°/-5° with optional tilt lock in 5° increments
- Horizontal display adjustment up to 8" (203mm) for better display placement
- 2.64" (67mm) from the wall
- Double stud mounting with 16", 20" & 24" stud placements
- Tamper-resistant hardware is standard and also has accommodations for optional padlocks
- Wood, concrete or cinder block mounting hardware included

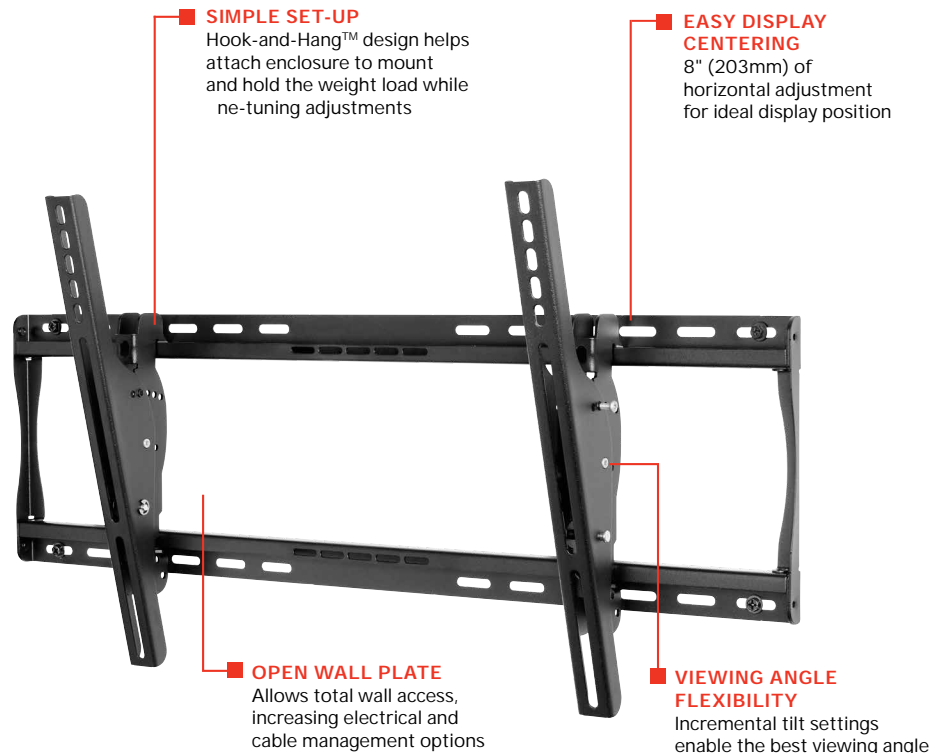

One-Touch™ tilt adjustment of +15°/-5°



Please visit [peerless-av.com/en-us/patents](http://peerless-av.com/en-us/patents) for patent information.

EPT650	Outdoor Universal Tilt Wall Mount for 32" to 75" Displays				
--------	---	--	--	--	--

Product Specifications

	DIMENSIONS (W x H x D)	PRODUCT WEIGHT	LOAD CAPACITY	FINISH	AVAILABLE COLORS
EPT650	30.87" x 16.89" x 2.64"-5.51" (784 x 429 x 67-140mm)	8.5lb (4kg)	175lb (79kg)	E-Coat Covered with Outdoor Powder Paint	Black

Package Specifications

	PACKAGE SIZE (W x H x D)	PACKAGE SHIP WEIGHT	PACKAGE UPC CODE	PACKAGE CONTENTS	UNITS IN PACKAGE
EPT650	32.00" x 3.63" x 10.25" (813 x 92 x 260mm)	10.5lb (5kg)	735029275640	Mount and Mounting Hardware	1

Accessories

HDS-OWRE-300: Wireless Outdoor Module

Compatible with

- UV492: 49" UltraView™ UHD Outdoor TV
- UV552: 55" UltraView™ UHD Outdoor TV
- UV652: 65" UltraView™ UHD Outdoor TV
- XHB432: 43" Xtreme™ High Bright Outdoor Display
- XHB492: 49" Xtreme™ High Bright Outdoor Display
- XHB552: 55" Xtreme™ High Bright Outdoor Display

All dimensions = inch (mm)

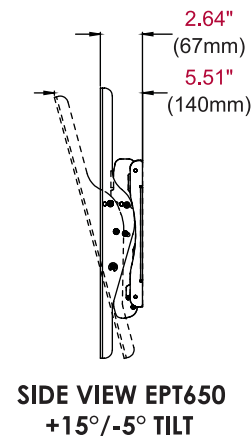
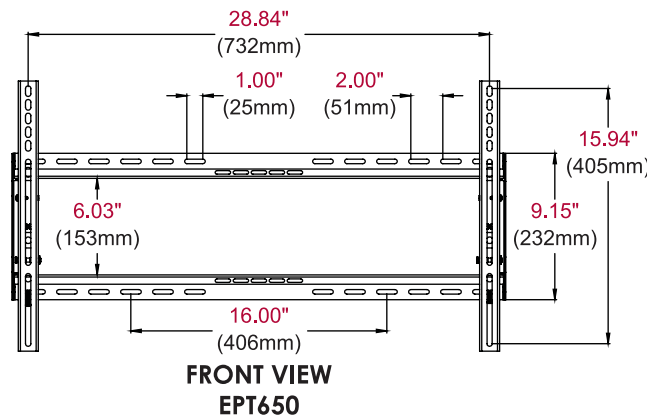
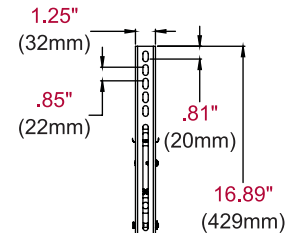
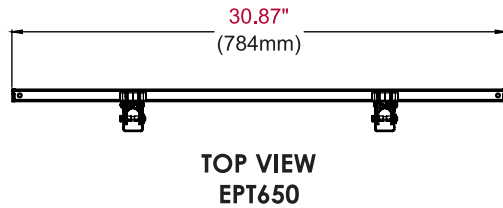

Architect Specifications

The Outdoor Universal Tilt Wall Mount shall be a Peerless-AV model EPT650 and shall be located where indicated on the plans. Assembly and installation shall be done according to instructions provided by the manufacturer.

Visit [peerless-av.com](http://peerless-av.com) to see the complete line of AV solutions from Peerless-AV, including outdoor displays, kiosks, digital audio, display mounts, projector mounts, carts/stands, and a full assortment of accessories.

**Peerless-AV**  
2300 White Oak Circle  
Aurora, IL 60502 USA  
  
**(800) 865-2112**  
**(630) 375-5100**  
**Fax: (800) 359-6500**

**Peerless-AV EMEA**  
Unit 3 Watford Interchange  
Colonial Way, Watford  
Herts, WD24 4WP  
United Kingdom  
**+44 (0) 1923 200100**  
**Fax: +44 (0) 1923 200101**

**Peerless-AV Latin America**  
Av. de las Industrias 413  
Parque Industrial Escobedo  
General Escobedo, N.L.,  
México, 66062  
**+52 (81) 8384-8300**  
**Fax: +52 (81) 8384-8360**

