

## SR560-FLIP2



Mounting Pattern  
400 x 400mm



Max Load  
90lb (41kg)

# Mobile Cart with Rotational Interface

FOR THE 55" (WM55H, WM55R) AND 65" (WM65R) **SAMSUNG FLIP 2**

Peerless-AV's Mobile Cart with Rotational Interface has been designed to support the features and functionality of the 55" and 65" Samsung Flip 2 displays. Mobility, appealing design, display height adjustment and a pre-assembled base ensure quick assembly, while providing a rigid, but attractive structure to match the display's aesthetics. The 4" casters make it easy to move from room-to-room and optional bumper accessories ensure nothing is damaged along the way. The mount's rotational interface allows the user to easily rotate the display 90° from landscape to portrait, and holds the display at a 0° or -4.5° to further promote ergonomics with a more natural angled writing surface. The unique cable management system allows cables to be routed through the interface, which keeps the cabling safe and abrasion free when rotating the display. With a robust feature set featured on safety and durability, the Mobile Cart with Rotational Interface is ideal for collaboration spaces in corporate or education settings.

- Display can be located anywhere along the column for perfect viewing height (up to 60" at center)
- Rotational interface holds the display at a 0° or -4.5° to further promote ergonomics and a more natural writing surface
- Pre-assembled base provides rigidity, stability and quick assembly
- Gloss white, powder coat finish closely matches the Samsung Flip finish
- 400 x 400 VESA® and custom length M8 hardware provide the proper mounting solution for the Samsung Flip
- Cart includes (4) plastic base pads for instances when casters are not needed



### ■ PORTRAIT/LANDSCAPE

Rotational interface allows the display to be easily rotated from landscape to portrait orientation without any tools

### ■ CABLE MANAGEMENT ACCESS

Provides routing options on both sides of the mount for power and data

### ■ SAFE AND EASY MANEUVERABILITY

4" (102mm) swivel casters (two locking) meet UL/CUL requirements

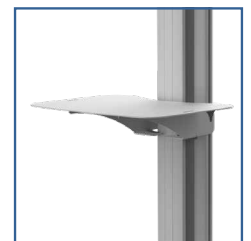

Shown with Rear Metal Shelf (ACC-MSF-W)



RoHS

SR560-FLIP2	Mobile Cart with Rotational Interface for the 55" (WM55H, WM55R) and 65" (WM65R) Samsung Flip 2
-------------	---

Product Specifications

	DIMENSIONS (W X H X D)	PRODUCT WEIGHT	LOAD CAPACITY	FINISH	AVAILABLE COLORS
SR560-FLIP2	35.01" x 67.73" x 29.00" (889 x 1720 x 737mm)	80.0lb (36.3kg)	90lb (41kg)	Powder Coat	Gloss White

Package Specifications

	PACKAGE SIZE (W x H x D)	PACKAGE SHIP WEIGHT	PACKAGE UPC CODE	PACKAGE CONTENTS	UNITS IN PACKAGE
SR560-FLIP2	48.00" x 38.00" x 7.00" (1219 x 965 x 178mm)	88. lb (40.1kg)	735029338086	Assembled Base, Aluminum Column, Universal Display Adaptor, (2) Swivel Casters, (2) Locking Swivel Casters, (4) Plastic Base Pads, Hardware & Instructions	1

Accessories

ACC310:	Leveling Feet Accessory	ACC-LA:	Laptop Arm
ACC316:	Safety Belt	ACC-MS:	Metal Shelf
ACC320:	Electrical Outlet Strip with Cord Wrap	ACC-MSF-W:	Rear Metal Shelf (White)
ACC-BPR:	Bumper Accessory for Legs		

All dimensions = inch (mm)

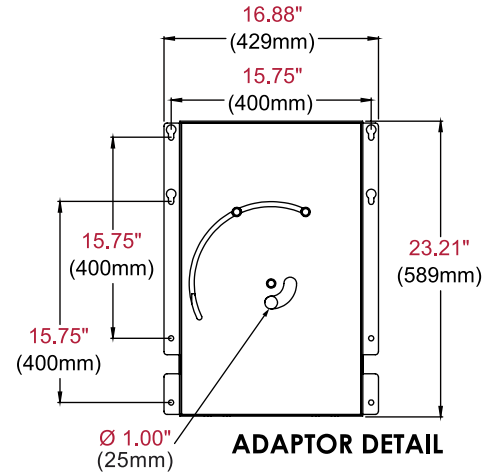
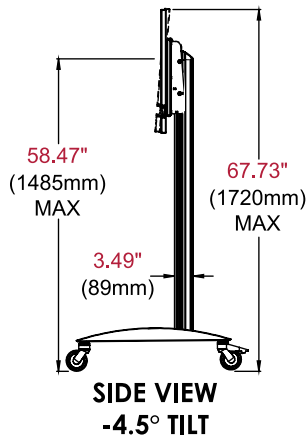
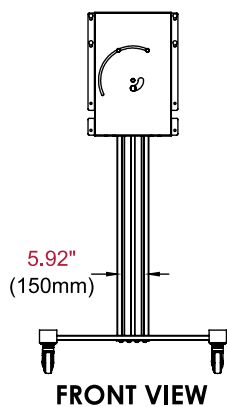
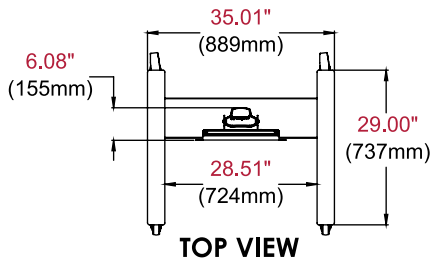

Architect Specifications

The Mobile Cart with Rotational Interface shall be a Peerless-AV model SR560-FLIP2 and shall be located where indicated on the plans. Assembly and installation shall be done according to instructions provided by the manufacturer.

Visit [peerless-av.com](http://peerless-av.com) to see the complete line of AV solutions from Peerless-AV, including outdoor displays, kiosks, digital audio, display mounts, projector mounts, carts/stands, and a full assortment of accessories.

**Peerless-AV**  
2300 White Oak Circle  
Aurora, IL 60502 USA  
  
**(800) 865-2112**  
**(630) 375-5100**  
**Fax: (800) 359-6500**

**Peerless-AV EMEA**  
Unit 3 Watford Interchange  
Colonial Way, Watford  
Herts, WD24 4WP  
United Kingdom  
**+44 (0) 1923 200100**  
**Fax: +44 (0) 1923 200101**

**Peerless-AV Latin America**  
Av. de las Industrias 413  
Parque Industrial Escobedo  
General Escobedo, N.L.,  
México, 66062  
**+52 (81) 8384-8300**  
**Fax: +52 (81) 8384-8360**

