

NOTES:

- 1. MATERIAL:ABS,COLOR:RAL9003
- 2. BURR:0.05mm MAX

LItemref	Quantity	Title/Name,designation,material,dimension etc	Article No./Reference		
Designed by	Checked by	Approved by - date Sep.07.2017	File name Double Back Box	Date Sep.07.2017	Scale FREE
ANGLE 			Double gang 42mm back box		
UNIT:MM			20-1100-7	Edition 1	Sheet 1/1

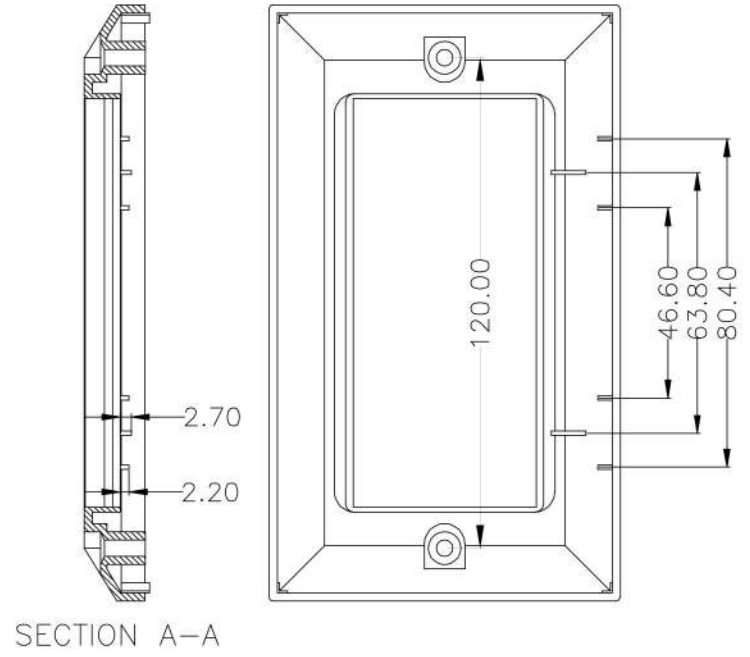
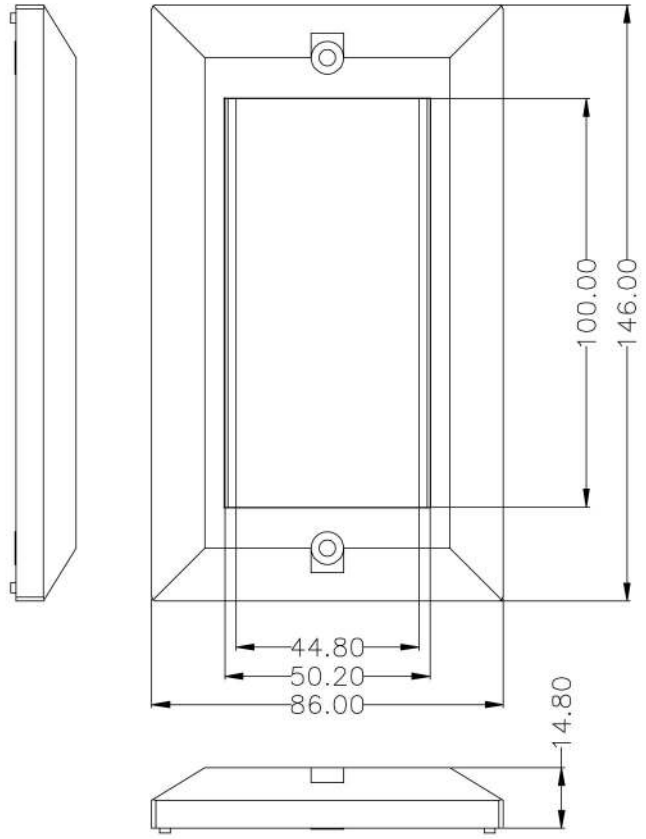

NOTE:
 1.MATERIAL:,COLOR:RAL9003
 2.BURR:0.05mm MAX

Itemref	Quantity	Title/Name,designation,material,dimension etc	Article No./Reference
Designed by:	Checked by:	Approved by - date Sep.07.2017	File name Double Face Plate Date Sep.07.2017 Scale FREE
ANGLE		Double gang face plate	
UNIT:MM		20-1100-6	Edition 1 Sheet 1/1

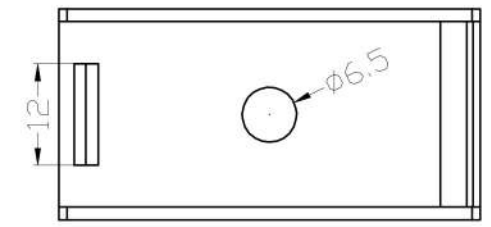
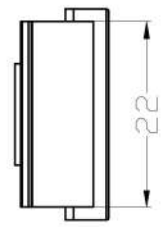
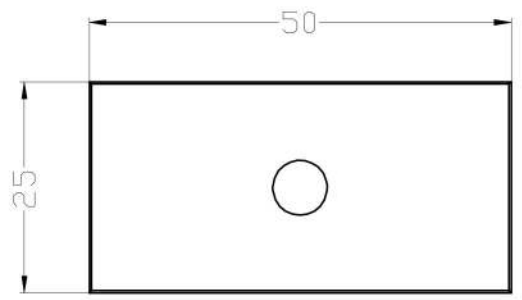
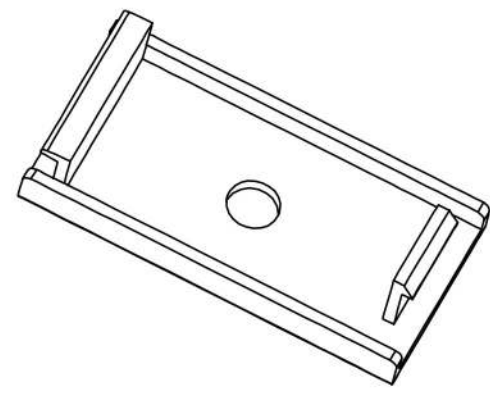
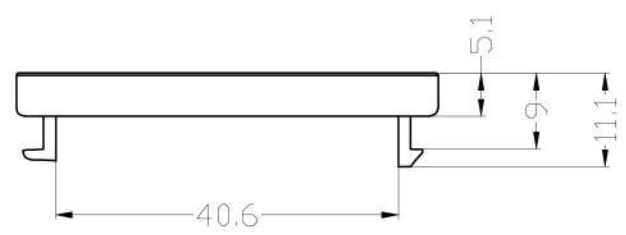

NOTE:
 1.MATERIAL:,COLOR:RAL9003
 2.BURR:0.05mm MAX

Itemref	Quantity	Title/Name,designation,material,dimension etc	Article No./Reference		
Designed by	Checked by	Approved by - date Sep.07.2017	File name 3.5MM face Plate	Date Sep.07.2017	Scale FREE
ANGLE:		3.5MM face plate			
UNIT MM			20-1100-10-1	Edition 1	Sheet 1/1

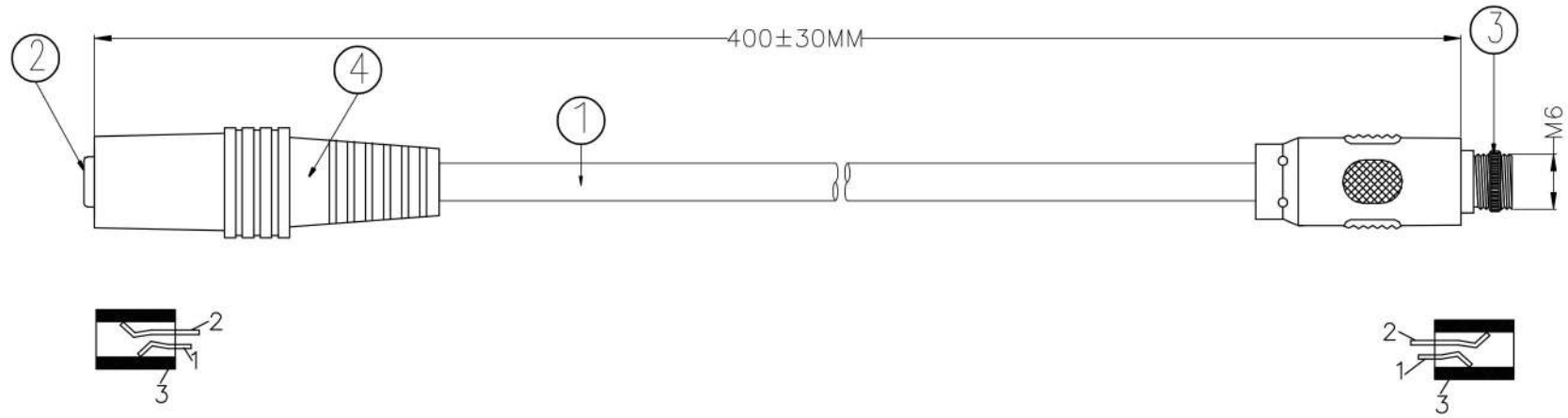

NOTES:

- 1:100% short,open and miss wire test.
- 2:Cable no marking
- 3:RoHS & REACH Compliant

PIN OUT

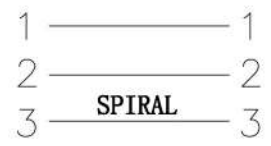

NO.	MATERIAL	DESCRIPTION	QTY.	UNIT
④	OUTER MOULDED	BLACK 45P PVC	0.021	KG
③	CONNECTOR	3.5 STEREO FEMALE:SOLDER TYPE,NICKEL PLATED CONTACT,BAND SCREW(PJ-392)	1	PCS
②	CONNECTOR	3.5 STEREO FEMALE:SOLDER TYPE,NICKEL PLATED CONTACT	1	PCS
①	CABLE	2C*7/0.12BC+SPIRAL28*0.1BC,JACKET:BLACK PVC,OD:4.0±0.2MM	400	MM

Ltemref	Quantity	Title/Name,designation,material,dimension etc	Article No./Reference		
Designed by	Checked by	Approved by - date Sep.07.2017	File name 3.5MM-F-0.4M	Date Sep.07.2017	Scale FREE
ANGLE:	ADAPTOR LEAD, 3.5MM 3PIN,F/F,0.4M				
UNIT:MM	20-1100-10-2			Edition 1	Sheet 1/1

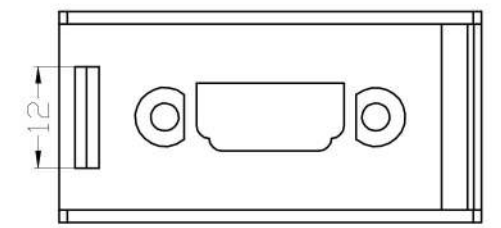
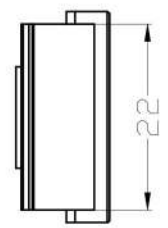
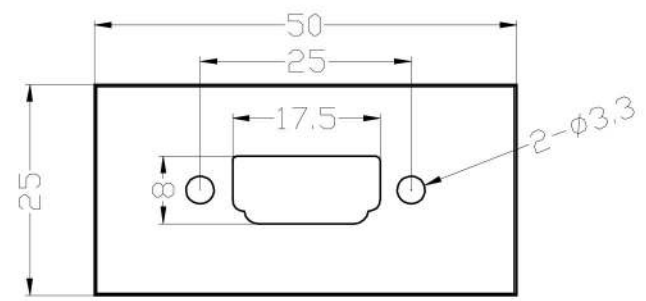
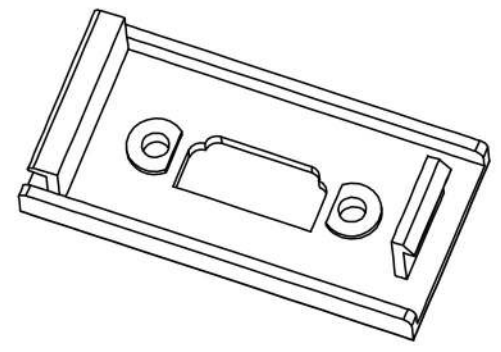
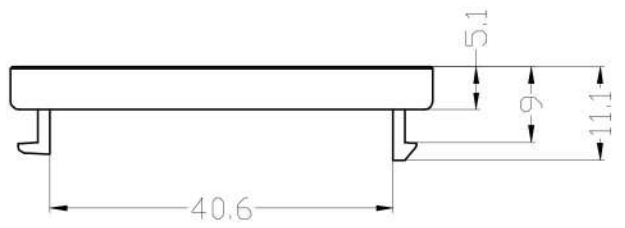

NOTE:
 1.MATERIAL:,COLOR:RAL9003
 2.BURR:0.05mm MAX

Ltremref	Quantity	Title/Name,designation,material ,dimension etc	Article No./Reference		
Designed by	Checked by	Approved by - date Sep.07.2017	File name HDMI face Plate	Date Sep.07.2017	Scale FREE
ANGLE		HDMI face plate 50*25MM			
UNIT:MM		20-1100-8-1	Edition 1	Sheet 1/1	

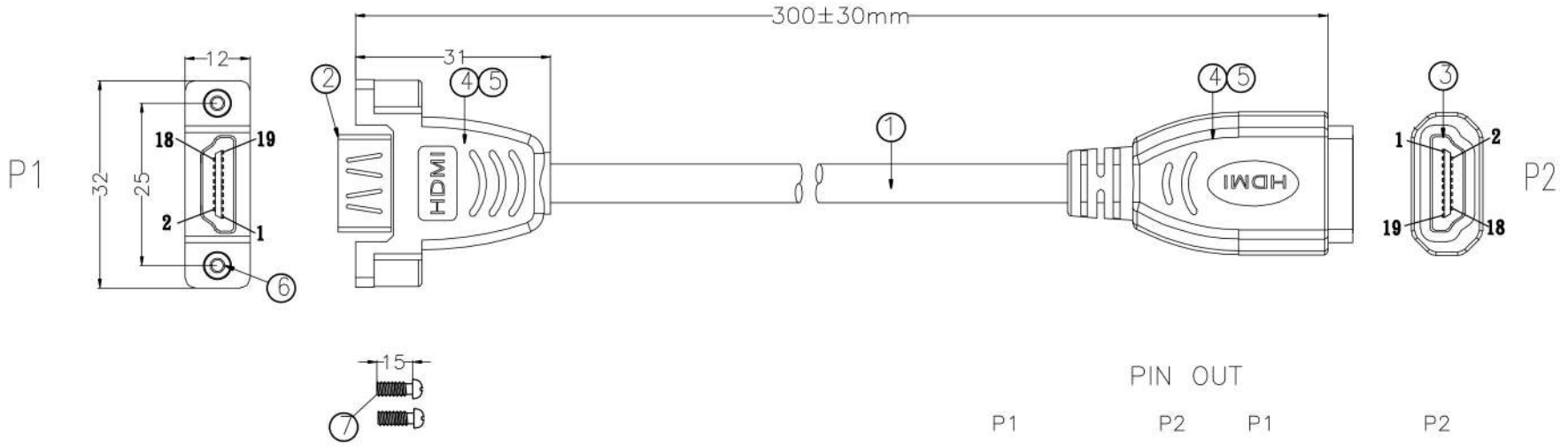

NOTES:

- 1:100% short,open and miss wire test.
- 2:HDTV:1080P,60HZ
- 3:RoHS & REACH Compliant

PIN OUT

P1		P2	
1	10	1	10
3	12	3	12
5	8	5	8
4	13	4	13
6	15	6	15
2	16	2	16
7	18	7	18
9	14	9	14
11	19	11	19
SHELL	17	SHELL	17

⑦	SCREW	THUMB SCREW #4-40*15	2	PCS
⑥	NUT	NUT-NICKEL PLATED #4-40	2	PCS
⑤	OUTER MOULDED	BLACK 45P PVC	0.025	KG
④	INNER MOULDED	LDPE	0.012	KG
③	CONNECTOR	HDMI A/F WITH BLACK CAOVER:SOLDER TYPE,GOLD PLATED PIN AND SHELL.	1	PCS
②	CONNECTOR	HDMI A TYPE FEMALE:SOLDER TYPE,GOLD PLATED PIN AND SHELL.	1	PCS
①	CABLE	(28AWG*1P+D+FAM)*5+28AWG*4C+ADB,JACKET:BLACK PVC,OD:7.3±0.2mm	300	MM
NO.	MATERIAL	DESCRIPTION	QTY.	UNIT

Ltemref	Quantity	Title/Name,designation,material,dimension etc			Article No./Reference	
Designed by	Checked by	Approved by - date Sep.07.2017	File name HDMI,F,0.3M	Date Sep.07.2017	Scale FREE	
ANGLE:		ADAPTOR LEAD, HDMI, F/F, 0.3M				
UNIT:MM		20-1100-8-2		Edition 1	Sheet 1/1	

RevNo	Revision note	Date	Signature	Checked
6				
7				
8				

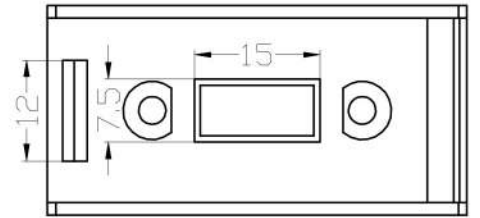
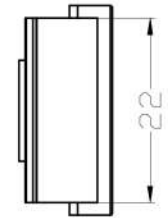
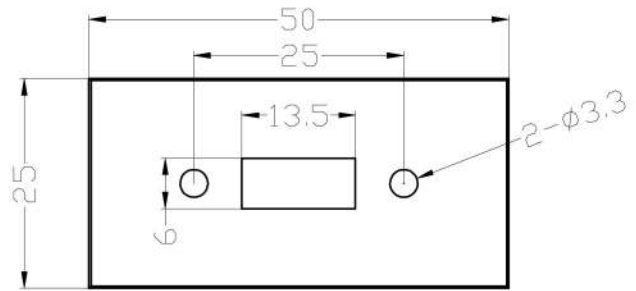
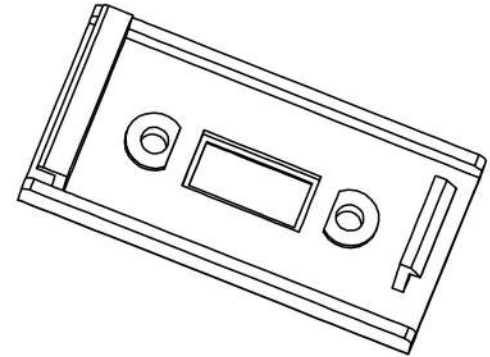
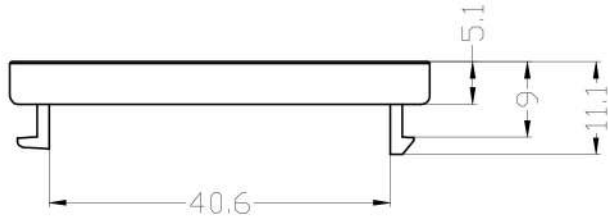

NOTE:
 1.MATERIAL:,COLOR:RAL9003
 2.BURR:0.05mm MAX

Itemref	Quantity	Title/Name,designation,material,dimension etc	Article No./Reference
Designed by	Checked by	Approved by - date Sep.07.2017	Date Sep.07.2017
ANGLE:		USB face plate 50*25MM	
UNIT:MM		20-1100-9-1	Edition 1 Sheet 1/1

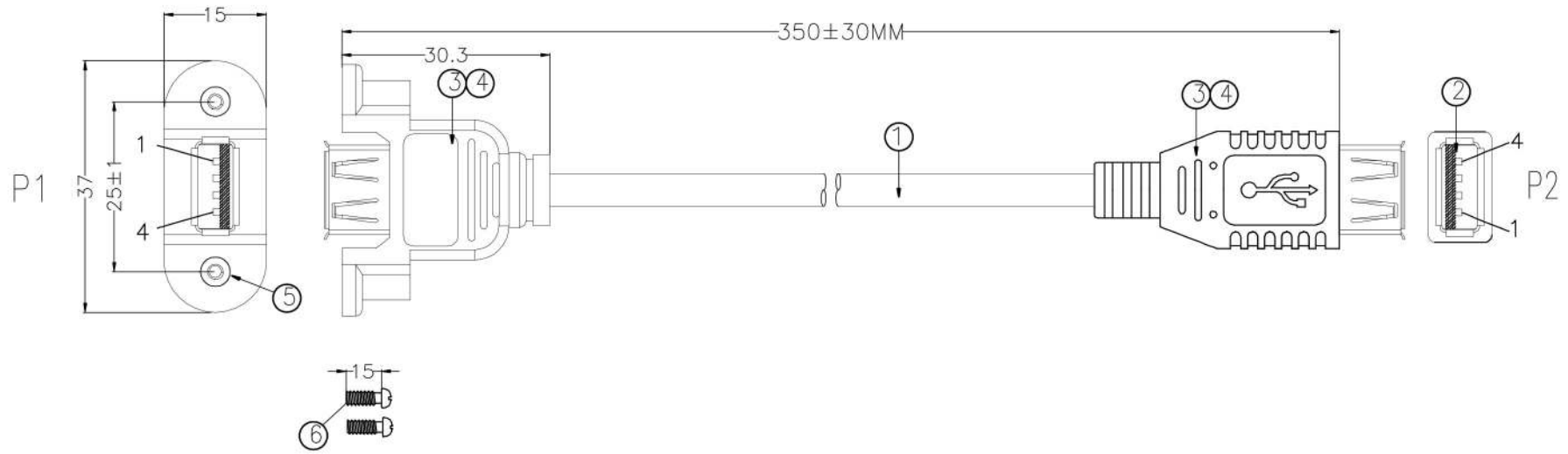

NOTES:

- 1:100% short,open and miss wire test.
- 2:RoHS & REACH Compliant

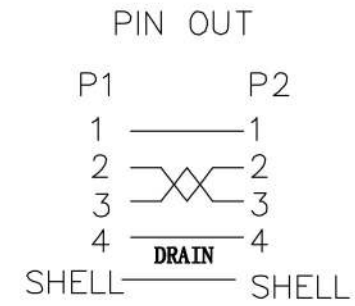

⑥	SCREW	THUMB SCREW #4-40*15	2	PCS
⑤	NUT	NUT-NICKEL PLATED #4-40	2	PCS
④	OUTER MOULDED	BLACK 45P PVC	0.025	KG
③	INNER MOULDED	LDPE	0.012	KG
②	CONNECTOR	USB A TYPE FEMALE,GOLD PLATED PIN,NICKEL PLATED SHELL,WHITE INSULATION	2	PCS
①	CABLE	UL2725 28AWG*1P+24AWG*2C+ADB,JACKET:BLACK PVC,OD:4.8±0.2mm	350	MM
NO.	MATERIAL	DESCRIPTION	QTY.	UNIT

Ltemref	Quantity	Title/Name,designation,material,dimension etc			Article No./Reference
Designed by	Checked by	Approved by - date Sep.07.2017	File name USB_AF-AF_0.35M	Date Sep.07.2017	Scale FREE
ANGLE:	ADAPTOR LEAD, USB2.0, AF/AF, 0.35M				
UNIT:MM	20-1100-9-2			Edition 1	Sheet 1/1

RevNo	Revision note	6	7	8
Date	Signature	Checked		

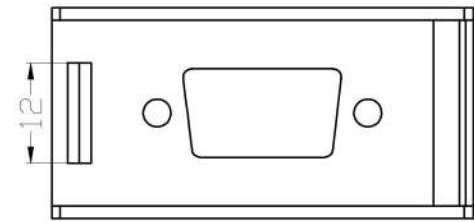
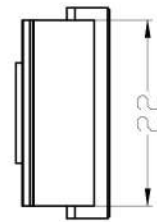
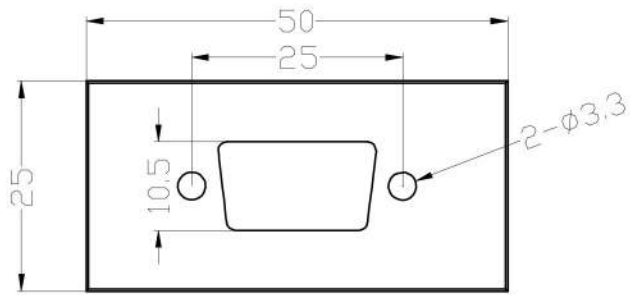
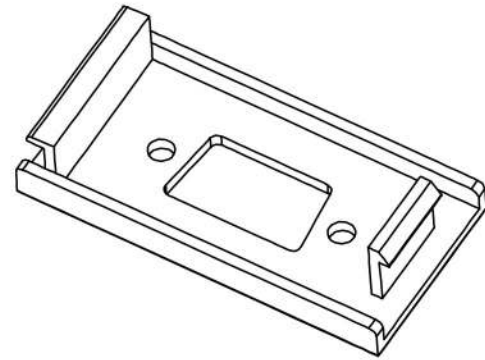
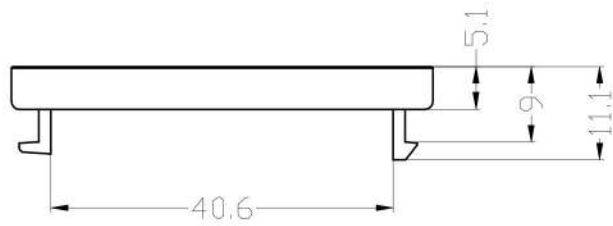

NOTE:

- 1.MATERIAL:,COLOR:RAL9003
- 2.BURR:0.05mm MAX

LItemref	Quantity	Title/Name,designation,material,dimension etc	Article No /Reference		
Designed by	Checked by	Approved by - date Sep.07.2017	File name VGA face Plate	Date Sep.07.2017	Scale FREE
ANGLE		VGA face plate 50*25MM			
UNIT:MM		20-1100-11-1	Edition 1	Sheet 1/1	

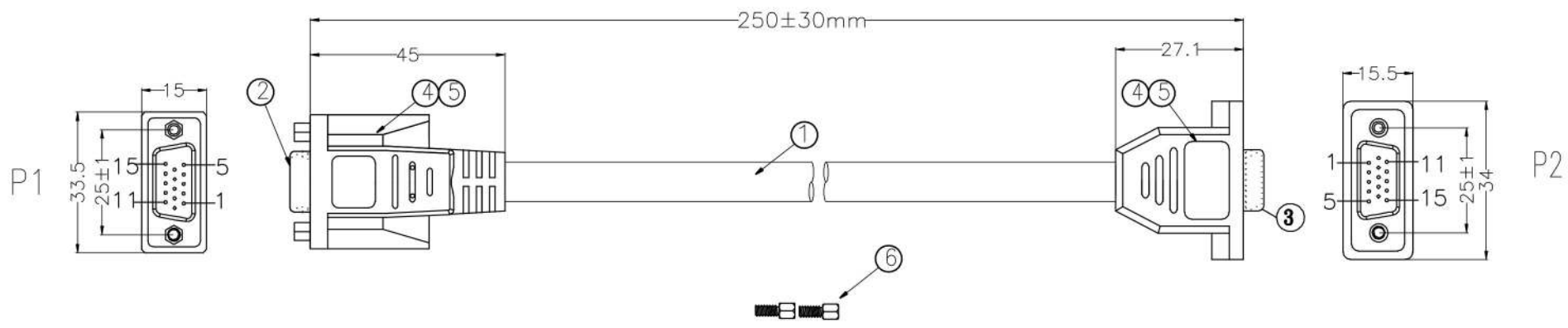

NOTES:

- 1:100% short,open and miss wire test.
- 2:RoHS & REACH Compliant

PIN OUT

P1	P2	P1	P2
1 Red coax conductor	1	9	9
2 Green coax conductor	2	10	10
3 Blue coax conductor	3	11	11
4	4	12	12
5	5	13	13
6 Red coax drain	6	14	14
7 Green coax drain	7	15	15
8 Blue coax drain	8	shell	Drain shell

NO.	MATERIAL	DESCRIPTION	QTY.	UNIT
⑥	SCREW	THUMB SCREW #4-40*12	2	PCS
⑤	OUTER MOULDED	BLACK 45P PVC	0.025	KG
④	INNER MOULDED	LDPE	0.012	KG
③	CONNECTOR	HDB15/F+AFTR RIVET NUT,GOLD FLASH PIN,NICKEL PLATED SHELL,BLUE INSULATION	2	PCS
②	CONNECTOR	HDB15/F+FRONT RIVET NUT,GOLD FLASH PIN,NICKEL PLATED SHELL,BLUE INSULATION	2	PCS
①	CABLE	(1C*28AWG+FPE+D+AL+PVC)X3+28AWGX9C+ADB,JACKET:BLACK PVC,OD:8.0±0.2MM	250	MM

Itemref	Quantity	Title/Name,designation,material,dimension etc			Article No./Reference	
Designed by	Checked by	Approved by - date	File name	Date	Scale	
		Sep.07.2017	VGA F-F,0.25M	Sep.07.2017	FREE	
ADAPTOR LEAD, VGA, F/F, 0.25M						
20-1100-11-2				Edition	Sheet	
				1	1/1	

UNIT:MM

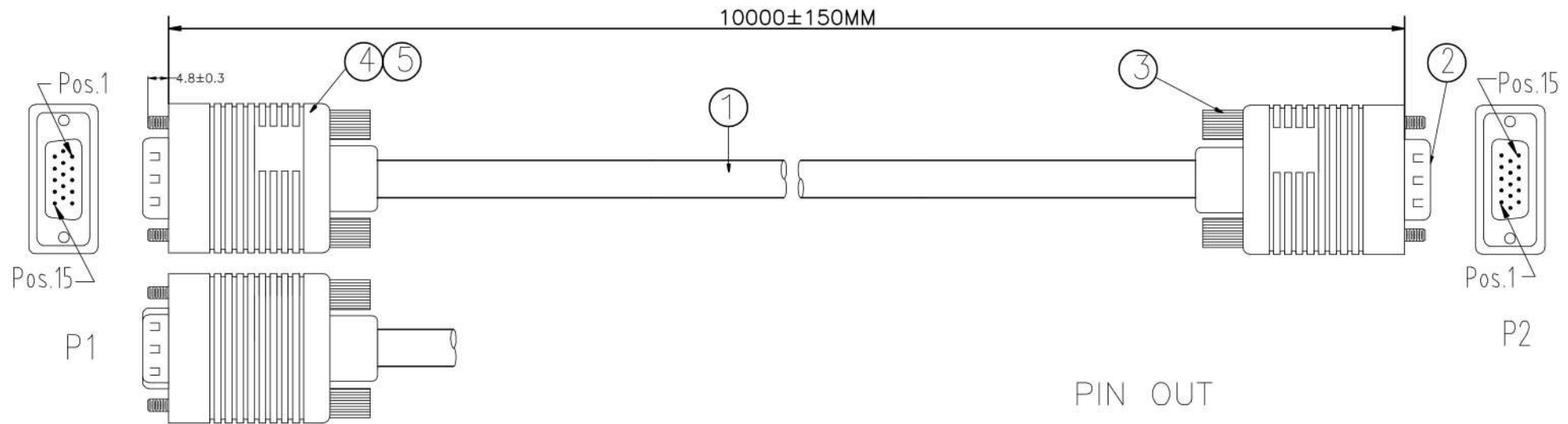

PIN OUT

P1	P2	P1	P2
1	Red coax conductor	9	9
2	Green coax conductor	10	10
3	Blue coax conductor	11	11
4		12	12
5		13	13
6	Red coax drain	14	14
7	Green coax drain	15	15
8	Blue coax drain	shell	Drain shell

NOTES:

- 1:100% short,open and miss wire test.
- 2:Cable marking:CONNEkT GEAR AWM STYLE 2919 80℃ 30V LOW VOLTAGE Computer Cable RoHS & REACH Compliant

NO.	MATERIAL	DESCRIPTION	QTY.	UNIT
⑤	OUTER MOULDED	BLACK 45P PVC	0.048	KG
④	INNER MOULDED	LDPE	0.021	KG
③	SCREW	#4-40UNC 2.3*45.5MM, BLACK PVC	4	PCS
②	CONNECTOR	HDB 15PIN/MALE,BLUE INSULATOR,NICKEL PLATED SHELL,GOLD PLATED PIN,	2	PCS
①	CABLE	(1C*30AWG 7/0.1BC+FPE+D+PVC)*3C+9C*30AWG 7/0.10BC+AL+D+B, JACKET:BLACK PVC,OD:8.0±0.2MM	10000	MM

Ltemref	Quantity	Title/Name,designation,material,dimension etc			Article No./Reference
Designed by	Checked by	Approved by - date Sep.07.2017	File name VGAB-9,10M	Date Sep.07.2017	Scale FREE
ANGLE:		VGA(3+9),HDB15M-HDB15M,30AWG,BLACK,10M			
UNIT:MM				20-1100-1	Edition 1
				Sheet 1/1	

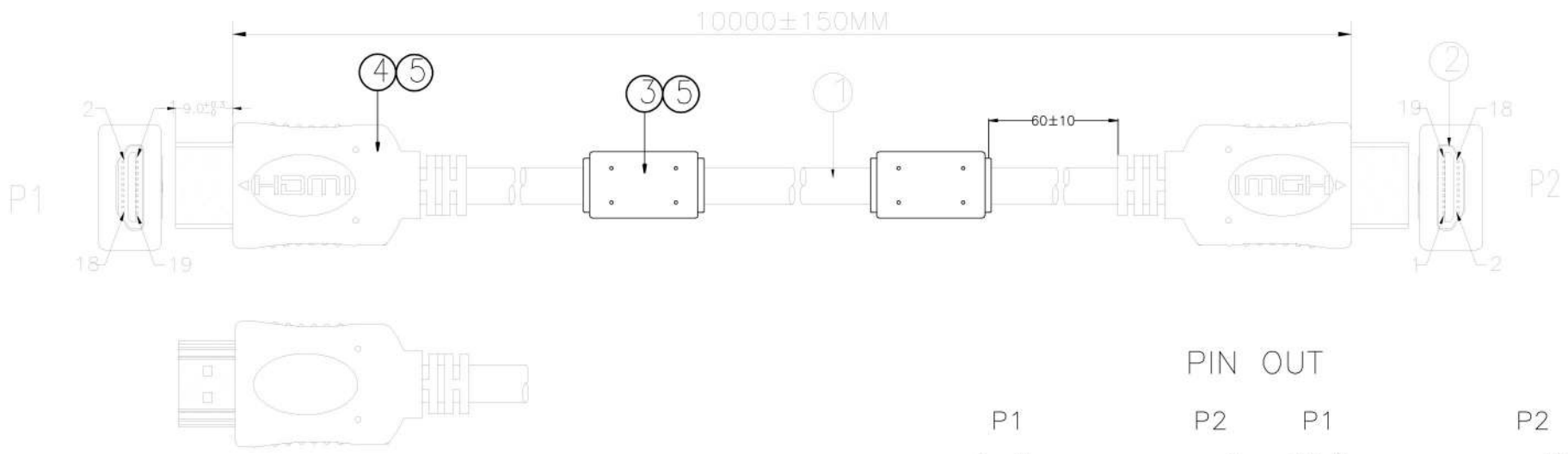

PIN OUT

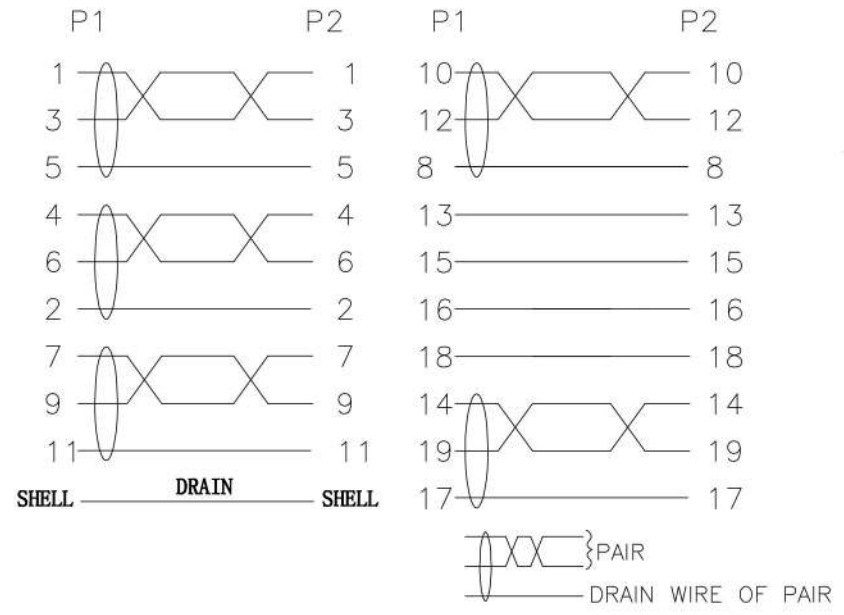

NOTES:

- 1:100% short,open and miss wire test.
- 2: Test Pass: 4K X 2K @ 60Hz
- 3: RoSH and REACH compliance

⑤	OUTER MOULDED	BLACK 45P PVC	0.078	KG
④	INNER MOULDED	LDPE	0.021	KG
③	FERRITE CORE	F5B:RH12.0*20*8.0	2	PCS
②	CONNECTOR	HDMI A TYPE MALE, BLACK INSULATOR, GOLD PLATED SHELL, GOLD PLATED PIN	2	PCS
①	CABLE	24AWG(1PX1/0.50BC+D 1/0.32BC+FAM)X5C+1/0.32BCX4C+AL+D 1/0.32BC+B(128/0.12ALM) ,OD:9.5	10000	MM
NO.	MATERIAL	DESCRIPTION	QTY.	UNIT

Item ref	Quantity	Title/Name, designation, material, dimension etc	Article No./Reference		
Designed by	Checked by	Approved by - date Sep.07.2017	File name HM20A/A	Date Sep.07.2017	Scale FREE
ANGLE	HDMI 2.0 M-M ,BLACK,10M				
UNIT:MM	20-1100-2			Edition 1	Sheet 1/1

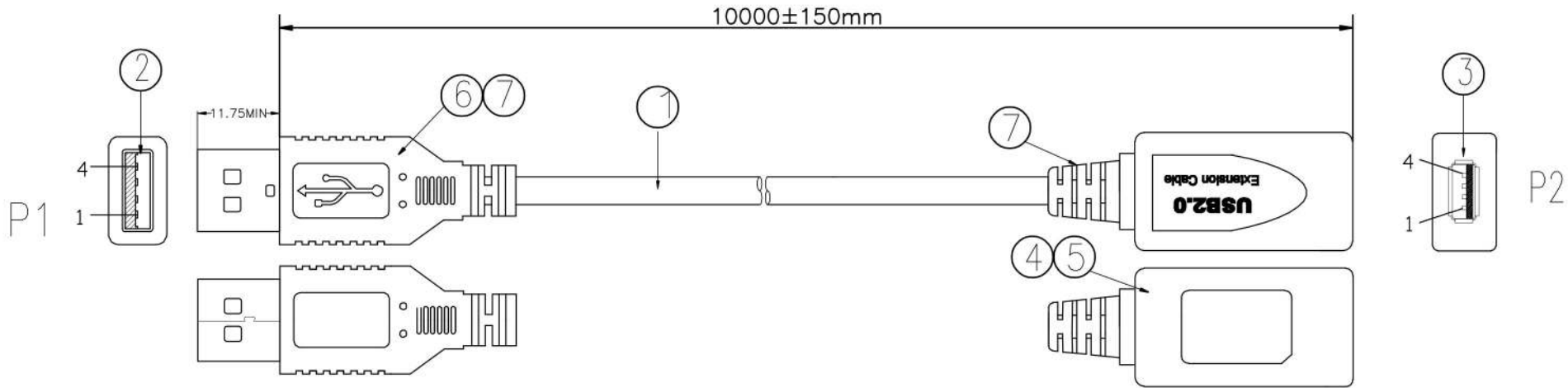

NOTES:

- 1:100% short,open and miss wire test.
- 2:Marking:CONNEkT GEAR AWM STYLE 2725 80°C 30V VW-1
USB2.0 High Speed Cable RoHS & REACH Compliant.
- 3:RoHS & REACH Compliant.

PIN OUT

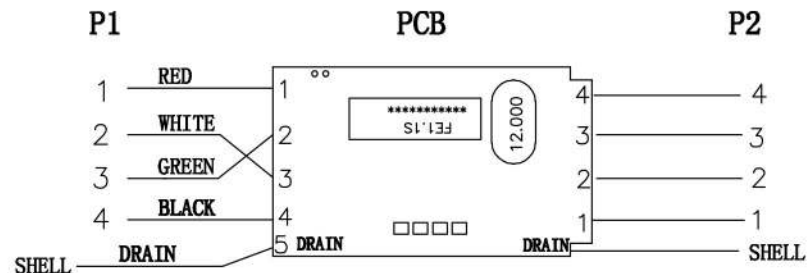

⑦	OUTER MOULDED	BLACK 45P PVC	0.032	KG
⑥	INNER MOULDED	LDPE	0.032	KG
⑤	PLASTIC SHELL	PLASTIC SHELL FOR AF,BLACK ABS,WITH GREY(SR7C) PRINTING.	1	PCS
④	PCB BOARD	PCB-FE1.1S	1	PCS
③	CONNECTOR	USB A TYPE FEMALE,WHITE INSULATOR,NICKEL PLATED SHELL,GOLD PLATED PIN	1	PCS
②	CONNECTOR	USB A TYPE MALE,WHITE INSULATOR,NICKEL PLATED SHELL,GOLD PLATED PIN	1	PCS
①	CABLE	1P*28AWG+2C*24AWG+ALF+D+B(64/0.1CCS),JACKET:BLACK PVC,OD:4.8±0.2MM	10000	MM
NO.	MATERIAL	DESCRIPTION	QTY.	UNIT

LItemref	Quantity	Title/Name,designation,material,dimension etc			Article No./Reference	
Designed by	Checked by	Approved by - date	File name	Date	Scale	
		Sep.07.2017	USB2.0 Extension Cable	Sep.07.2017	FREE	
ANGLE:	USB2.0 Extension Cable,AM-AF,10M					
UNIT:MM	20-1100-3		Edition	Sheet		
			1	1/1		

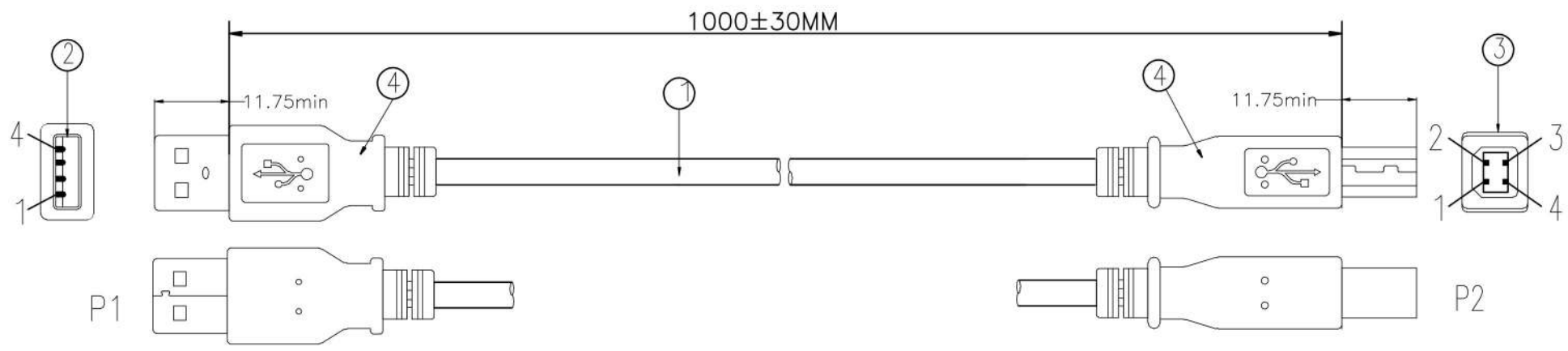

NOTES:

- 1:100% short,open and miss wire test.
- 2:Cable marking:CONNEKT GEAR AWM STYLE 2725 80°C 30V VW-1 USB2.0 High Speed Cable RoHS & REACH Compliant

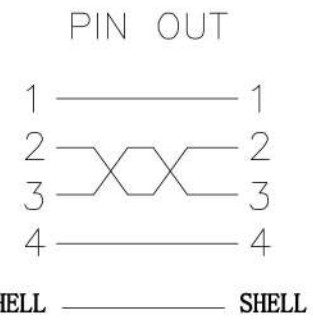

NO.	MATERIAL	DESCRIPTION	QTY.	UNIT
④	OUTER MOULDED	BLACK 45P PVC	0.021	KG
③	CONNECTOR	USB2.0 B TYPE/MALE,WHITE INSULATOR,NICKEL PLATED SHELL,GOLD PLATED PIN,	1	PCS
②	CONNECTOR	USB2.0 A TYPE/MALE,WHITE INSULATOR,NICKEL PLATED SHELL,GOLD PLATED PIN,	1	PCS
①	CABLE	1P*28AWG 7/0.12BC+2C*28AWG 7/0.12BC+AL+B,JACKET:BLACK PVC,OD:3.8±0.1MM	1000	MM

Ltemref	Quantity	Title/Name,designafion,material,dimension etc	Article No./Reference		
Designed by	Checked by	Approved by - date Sep.07.2017	File name USB2.# AM-BM	Date Sep.07.2017	Scale FREE
ANGLE:	USB 2.0 CONNECTION CABLE,AM-BM,BLACK,1M				
UNIT:MM					
			20-1100-4	Edition 1	Sheet 1/1

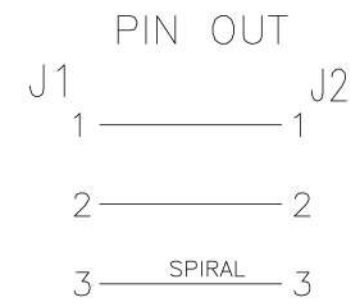
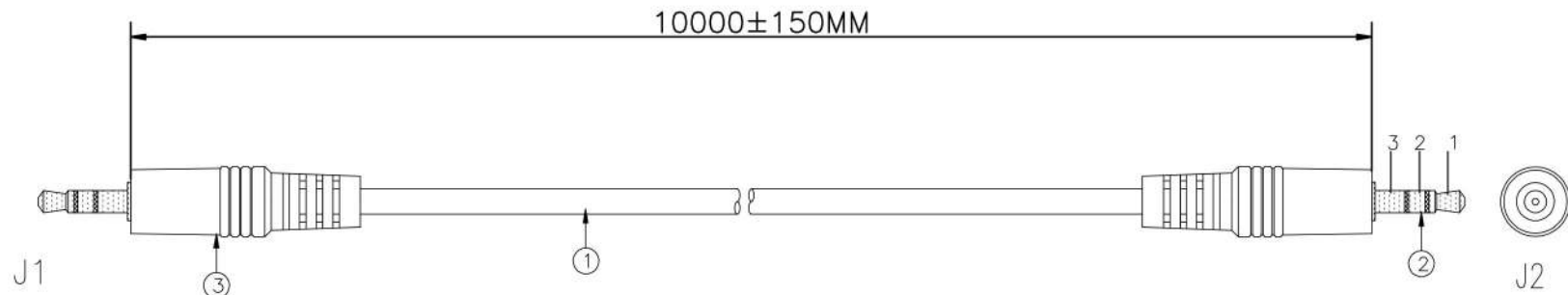

NOTES:

1:100% short,open and miss wire test.

NO.	MATERIAL	DESCRIPTION	QTY.	UNIT
③	OUTER MUOLDED	BLACK 45P PVC	0.020	KG
②	CONNECTOR	3.5/M STEREO PLUG SOLDER TYPE,BLACK INSULATOR,GOLD PLATED.	2	PCS
①	CABLE	28AWG 10/0.1CCS*2C+S/28*0.1CCS,JACKET:BLACK PVC,OD:3.0±0.15MM	10000	MM

Ltemref	Quantity	Title/Name,designation,material,dimension etc			Article No./Reference	
Designed by	Checked by	Approved by - date	File name	Date	Scale	
		Sep.07.2017	ST3.5M-ST3.5M	Sep.07.2017	FREE	
ANGLE:		AUDIO CABLE,ST3.5M-ST3.5M,BLACK,10M				
UNIT:MM		20-1100-5	Edition 1	Sheet 1/1		