

Tilt & Swivel Adjustment

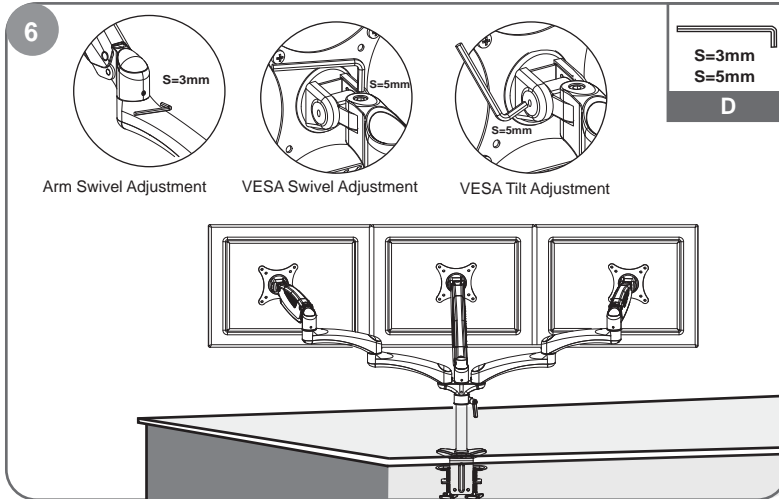

Tighten the bolt with the Allen Key to make the tilt and swivel adjustment.

Cable Management Installation

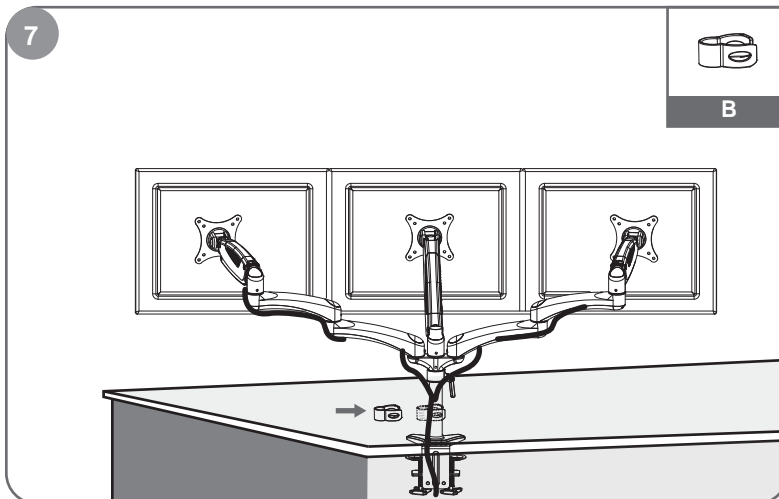

Organize cables with cable management clips along the pole.

Gas Spring Aluminum LCD Monitor Desk Mount



See more • Do more • Be more

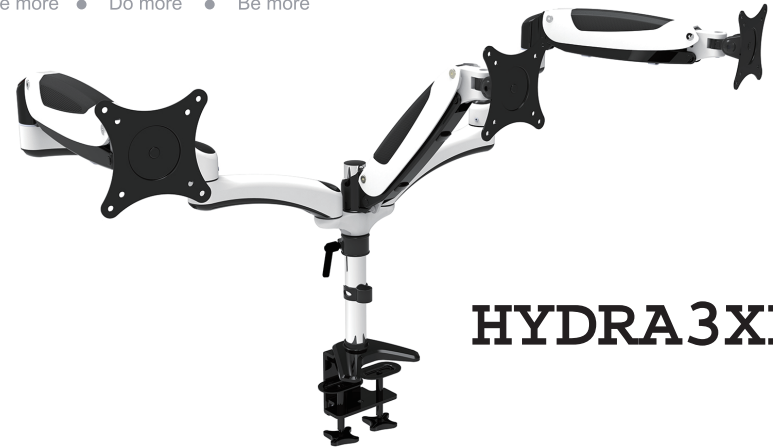

HYDRA 3XL

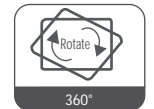
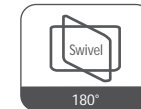
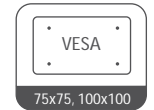
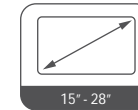

Amer Mounts
1-800-262-9703
Fax: 1-800-314-6805
Email: sales@amer.com





Technical support
1-888-998-9189
Email: support@amer.com

Installation

INSTRUCTIONS

WARNING STATEMENTS

Warning

-  Prior to the installation of this product, the installation instruction must be read and completely understood. Failure to do so may result in personal injury, property damage or voiding of factory warranty.
-  Do not install on a structure that is prone to vibration, movement or chance of impact. Reinforce the structure as required before installation. Don't use the product on particle board.
-  The desk clamp can support a maximum thickness of 9 cm. Confirm the desk edge before installation.
-  Pay attention to the weight capacity of the mount. Exceeding the limitation can result in function unworkable or even serious personal injury and property damage.
-  Never operate the mount if parts are missing or damaged. Contact your local service center for warranty service.

PRODUCT LINE GRAPH

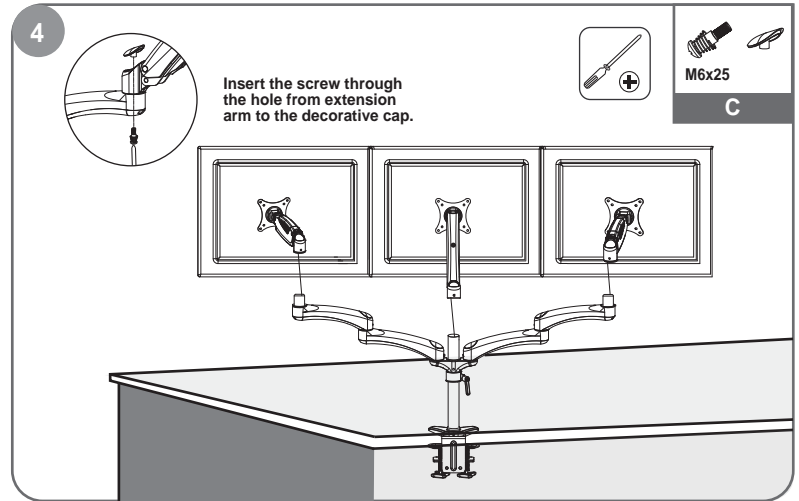
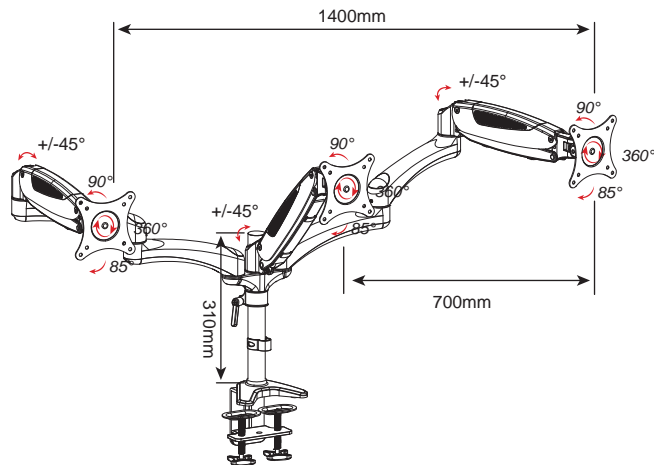

Lift the spring arm along with the monitor and put it on the supporting part.

Gas Spring Tension Adjustment

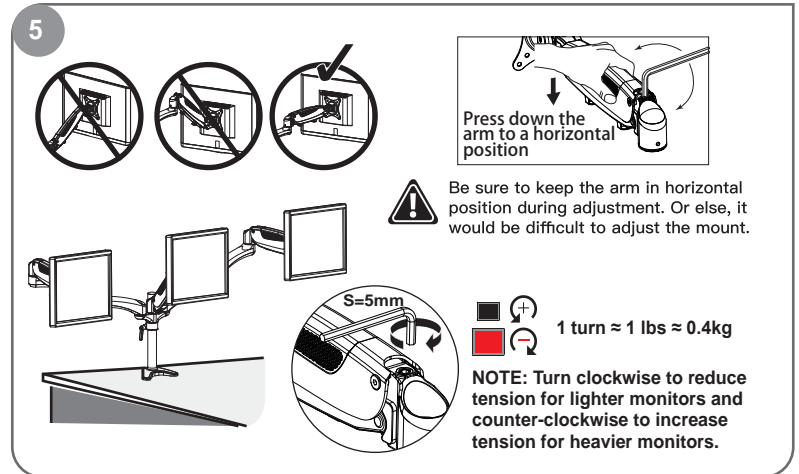

Use a hex wrench to adjust the height tension of the gas spring arm, to keep different weight of monitors still at any position.

Arm Installation

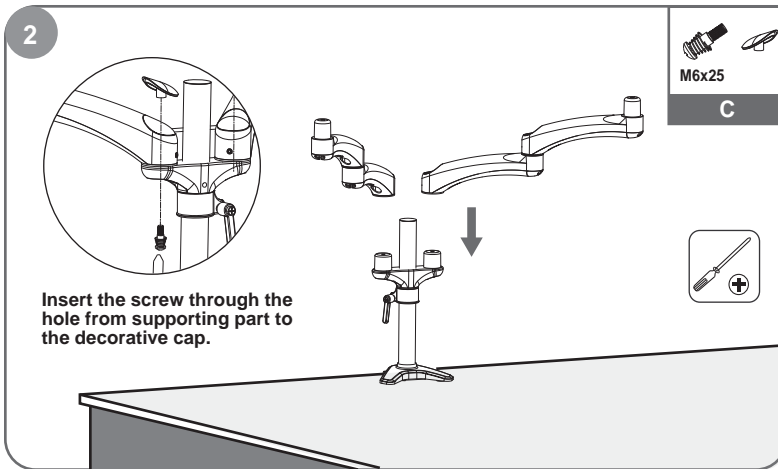

Insert extension arms to the supporting part.

Monitor Installation

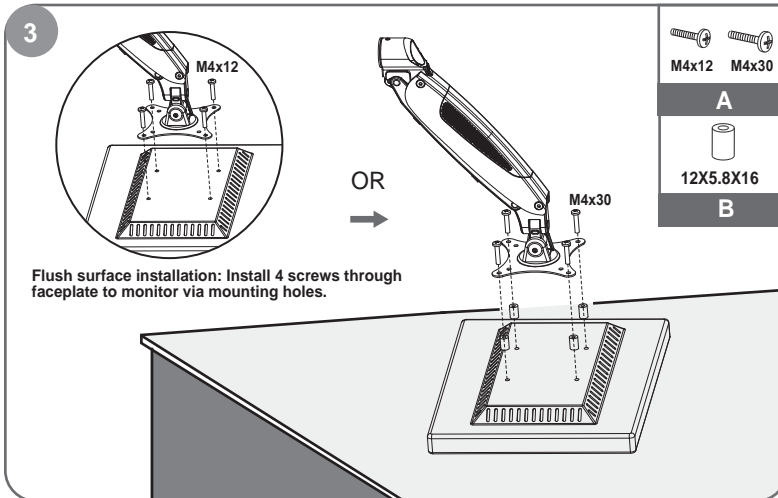

Recessed surface installation: Put 4 spacers between faceplate and monitor. Install 4 screws through faceplate, spacers to monitor via mounting holes.

TOOLS REQUIRED NOT INCLUDED



PARTS INCLUDED

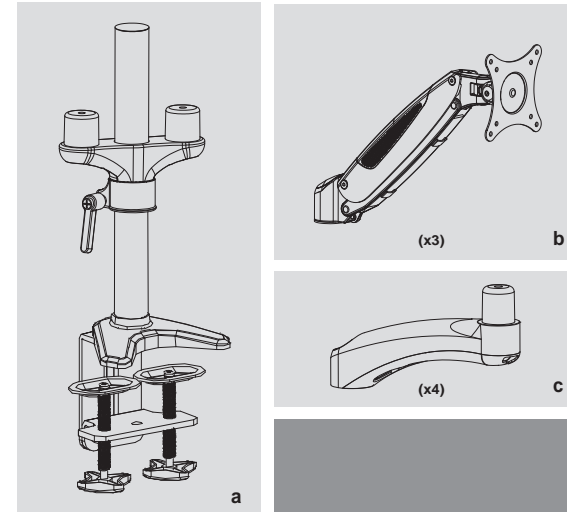

A	M4x12 (x12)	M4x30 (x12)
B	12X5.8X16 (x12)	(x1)

C	M6x25 (x6)	(x6)
---	------------	------

D	S=3mm (x1)	S=4mm (x1)	S=5mm (x1)
---	------------	------------	------------

E	(x1)
---	------

Clamp Installation Steps

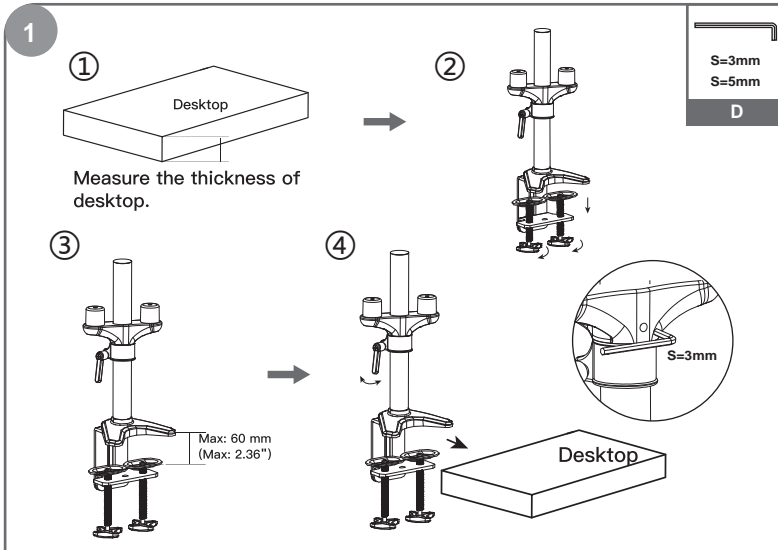

For desk thickness more than 2.36"(60mm) but within 3.35"(85mm), remove clamp screw and attachment entirely and reattach clamp screw with bottom plate upside-down.

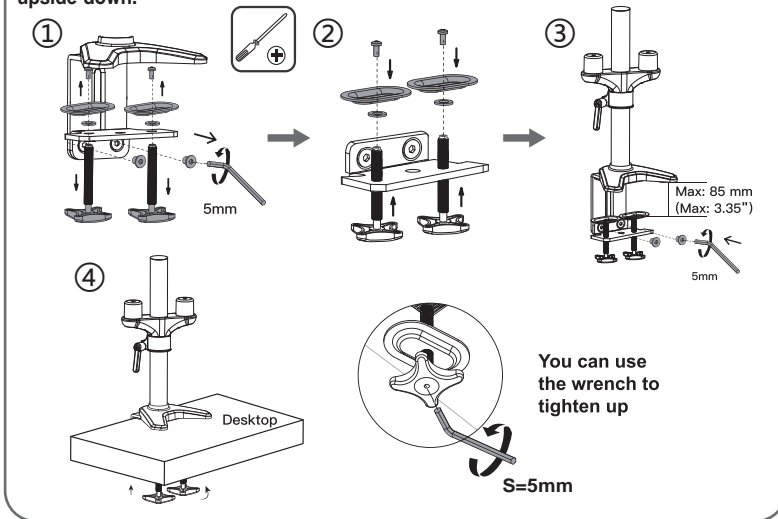

Grommet Installation Steps

