

## Replace pre-separation pad Replace separation roller

### Pre-separation Pad

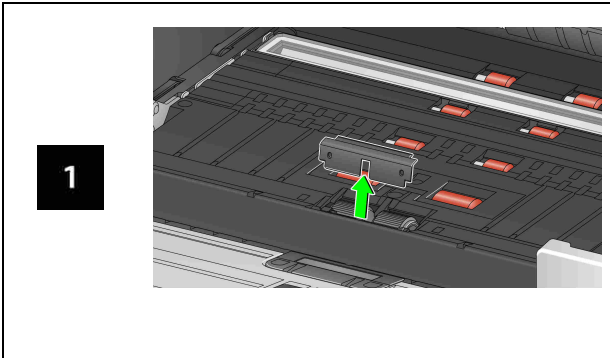

### Separation Roller

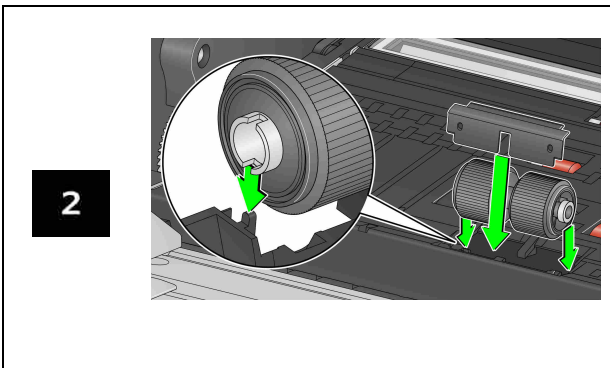
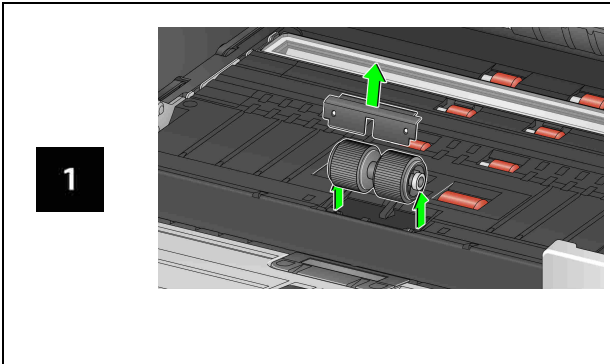

See the User's Guide for feed module and front transport roller replacement procedures.

## Supplies and Accessories

[www.alarisworld.com/go/S2000fsupport](http://www.alarisworld.com/go/S2000fsupport)

[www.alarisworld.com/go/S3000support](http://www.alarisworld.com/go/S3000support)

**Kodak**  
S2000f/S3000 Series Scanners

### Reference Guide

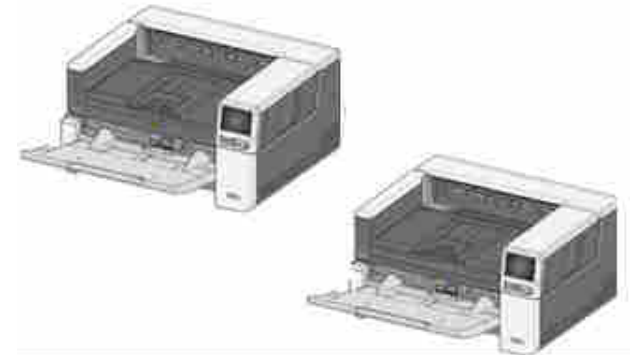

## Support Information

[www.kodakalaris.com/go/IMsupport](http://www.kodakalaris.com/go/IMsupport)

A-61929 / Part #5K8858 May 2020

All trademarks and trade names used are the property of their respective holders.

The Kodak trademark and trade dress are used under license from Eastman Kodak Company

© 2020 Kodak Alaris Inc.



When contacting support, have the following available:

- A description of your problem
- Scanner model and serial number
- Computer configuration
- Software application you are using

## Installation

The following is a list of steps you will need to perform in order to get your scanner set up and connected to your computer.

1. Unbox your scanner.
2. Setup your scanner for the first time.
3. Install driver software.
4. Verify the scanner's firmware.
5. Optionally update the scanner's firmware.
6. Optionally install available Kodak scanning software.

For more details refer to Section 2 of the User Guide which can be found in the manuals listed on the website:

[www.alarisworld.com/go/S2000support](http://www.alarisworld.com/go/S2000support)  
[www.alarisworld.com/go/S3000support](http://www.alarisworld.com/go/S3000support)

### OCP TIPS



1. Document count
2. Paper Present Indicator (if no paper is detected, this icon is displayed).
3. Scanner is connected to a computer via USB.
4. Scanner is connected to the Wired Network.

When the **tire icon** appears at the top of the scanner touch screen, it's time to clean the scanner or replace consumables (rollers, tires, etc).

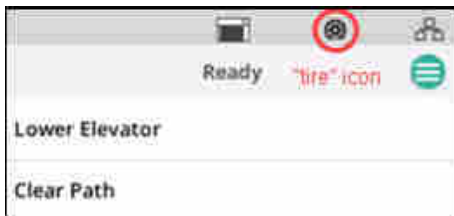

See "Maintenance" on page 29 of the User Guide.

The icon only appears if one of the maintenance meters has expired.

## Clean the transport, rollers and background strips

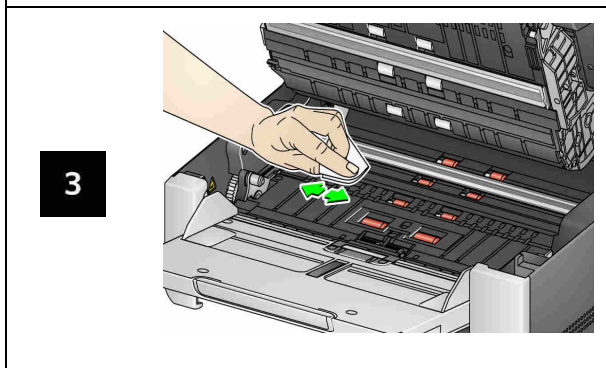
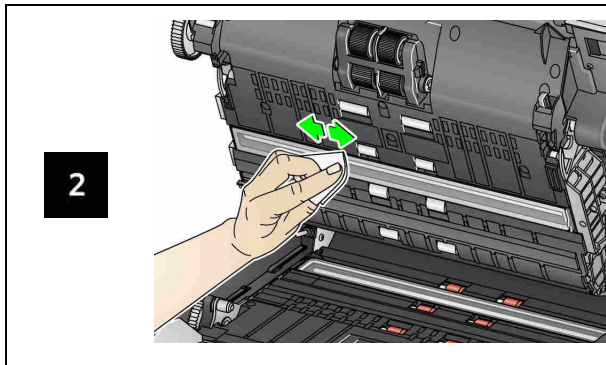
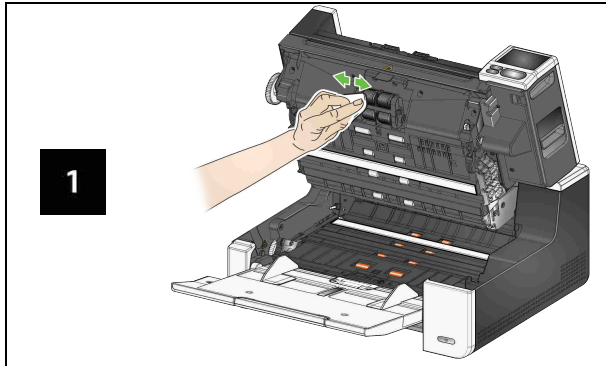

## Running a transport cleaning sheet and cleaning the imaging guides

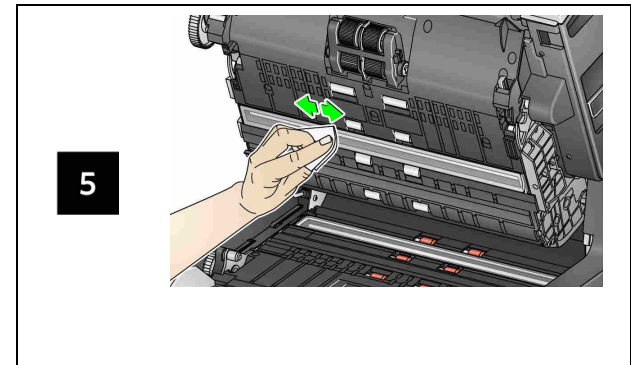
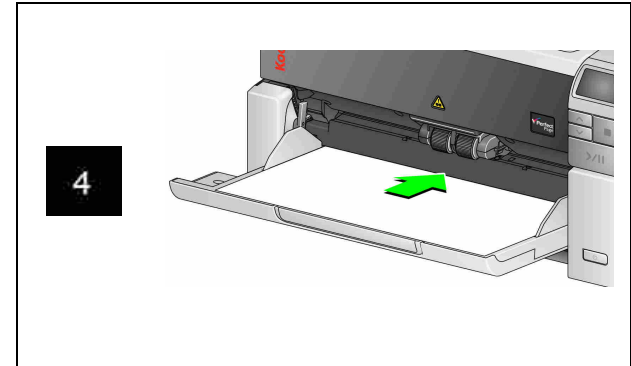

## Cleaning the flatbed glass (for the S2085f/S3060f/S3100f Scanners only)

