



## B) M.2 SSD: How to Install the M.2 2280 SSD

M.2 SSD: Wie Sie die M.2 SSD installieren / SSD M.2: Comment l'installer / M.2 SSD: Cómo instalar SSD M.2 / SSD M.2: Como instalar o SSD M.2 / M.2 SSD: Come installare un'unità M.2 SSD  
 Накопитель M.2 SSD: Порядок установки накопителя M.2 SSD / M.2 SSD: Jak zainstalować M.2 SSD / M.2 SSD: M.2 SSD nasıl kurulum yapılır / 如何安裝 M.2 SSD / 如何安裝 M.2 SSD  
 M.2 SSD : M.2 SSD の取り付け方法 / M.2 SSD : M.2 방식 SSD 을 설치하는 방법



## C) Memory Installation: SO-DIMM DDR4

Arbeitsspeicher Installation DDR4 / Installation de la mémoire DDR4 / Instalación de la Memoria DDR4 / Instalação da memória DDR4 / Installazione Memoria DDR4 / Установка модулей ОЗУ DDR4  
 Instalacja pamięci DDR4 / Bellek Yerleştirilmesi DDR4 / 安裝記憶體 / 安裝內存 / メモリの増設方法 DDR4 / 메모리 설치 DDR4

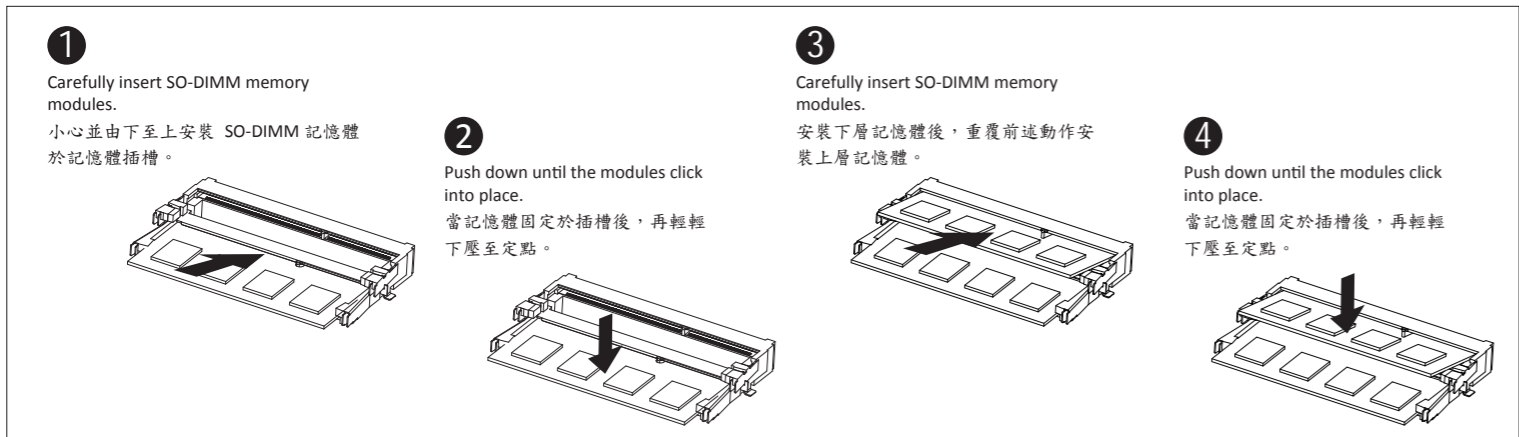

## D) BRIX s Support Additional SATA 6Gbps HDD: How to Install 2.5" HDD

BRIX s Unterstützt Zusätzliche SATA 6Gbps HDD: So installieren Sie die 2,5 "Festplatte / Le BRIX s supporte un disque dur SATA 6Gbps additionel: Comment l'installer  
 Soporte adicional HDD 6Gbps SATA para BRIXs: Cómo instalar HDD 2.5" / BRIX s Suporte adicional para HDD SATA 6Gbps: Como instalar HDD 2.5"  
 BRIX Supporta un' ulteriore porta SATA 6Gbps per HardDisk: Come installare un HDD da 2,5" / BRIX допускает установку дополнительного жесткого SATA-диска (6 Гбит/с): Порядок установки 2,5-дюйм жесткого диска  
 BRIX wspiera dodatkowy dysk SATA 6Gbps HDD: Jak zainstalować 2.5" HDD / BRIX, extra 6Gbps HDD destekler: 2.5" HDD nasıl kurulum yapılır / BRIX s 支援額外的 SATA 6Gbps 硬碟: 如何安裝 2.5" HDD  
 BRIX s 支援額外的 SATA 6Gbps 硬盘: 如何安裝 2.5" HDD / BRIXs SATA 6Gbp 하드디스크(HDD) 증設: 2.5 인치 HDD 의取り付け方法 / BRIX s 는 추가 SATA 6Gbps 을 지원합니다. HDD : 2.5" HDD 를 설치하는 방법

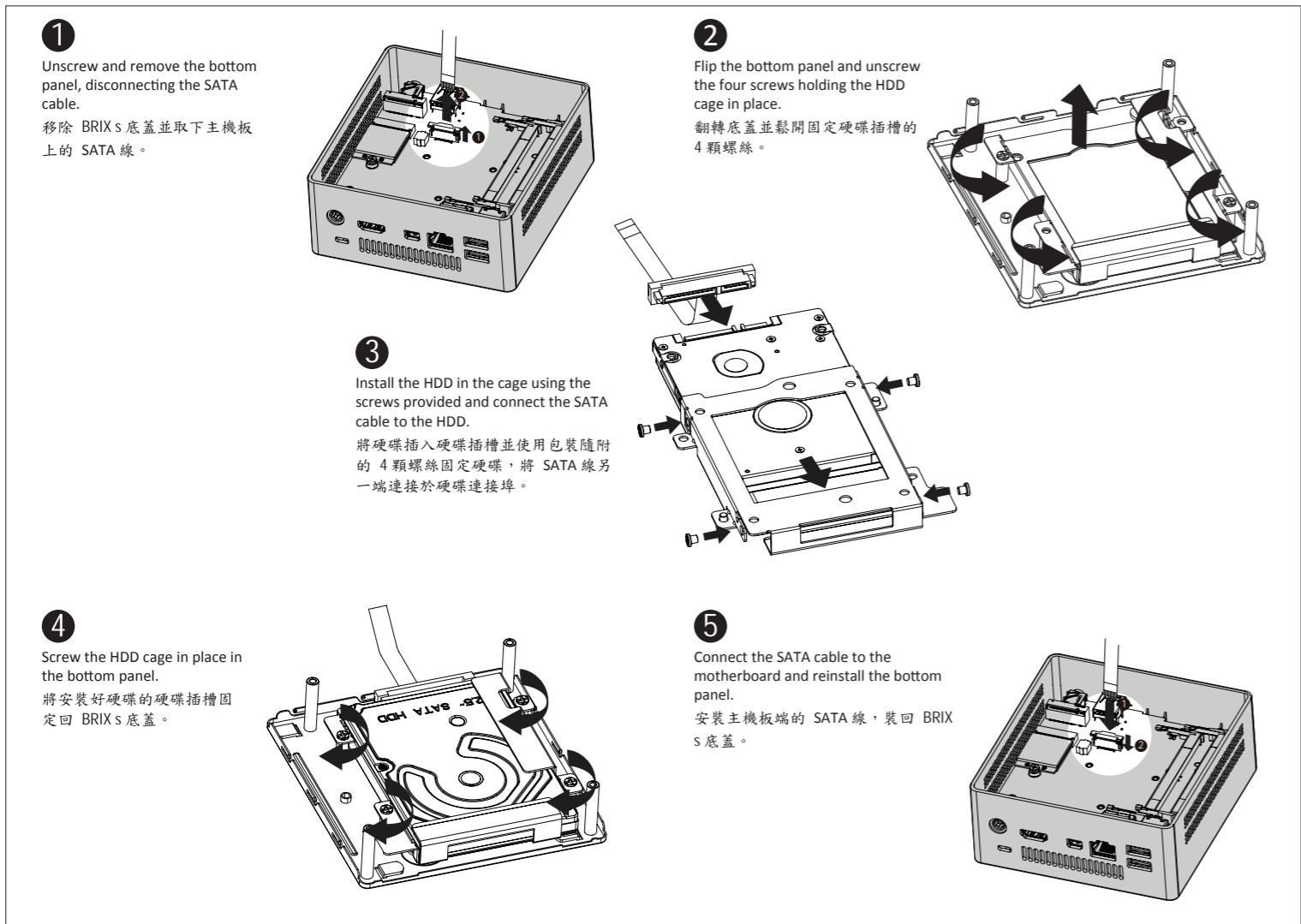

## VESA Bracket

VESA-Halterung / Support VESA / soporte VESA / Suporte VESA / Staffa VESA / Крепление VESA / Uchwył VESA / VESA Desteği / VESA 支架 / VESA 支架 / VESA 対応ブラケット / VESA Bracket

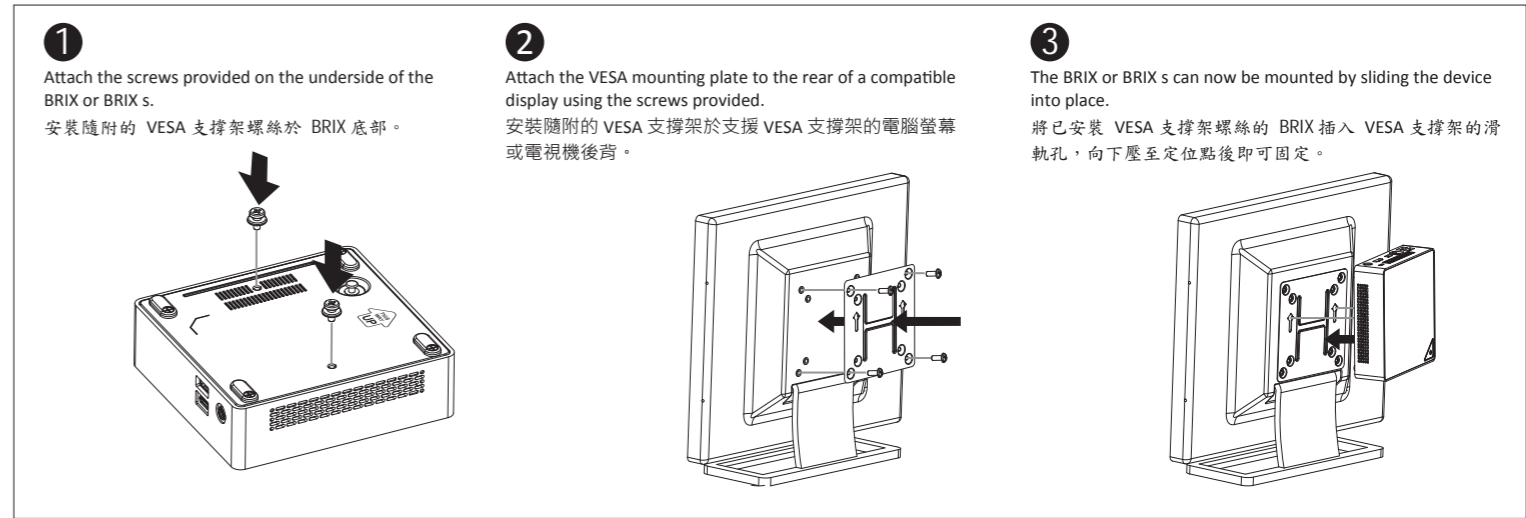

## USB Power On Function: Allows Device Power-on Via USB. Useful When Mounted Behind a Display or TV

USB Power On Funktion / Fonction Démarrage par USB / Función USB Power On  
 Função USB Power On / Funzione USB Power On / Функция USB Power On  
 Orçja USB Power On / USB Güç Açık Fonksiyonu / USB 埠啟動功能  
 USB 接口启动功能 / USB 機器からの電源 ON 機能 / USB 포트를 이용한 전원 켜기

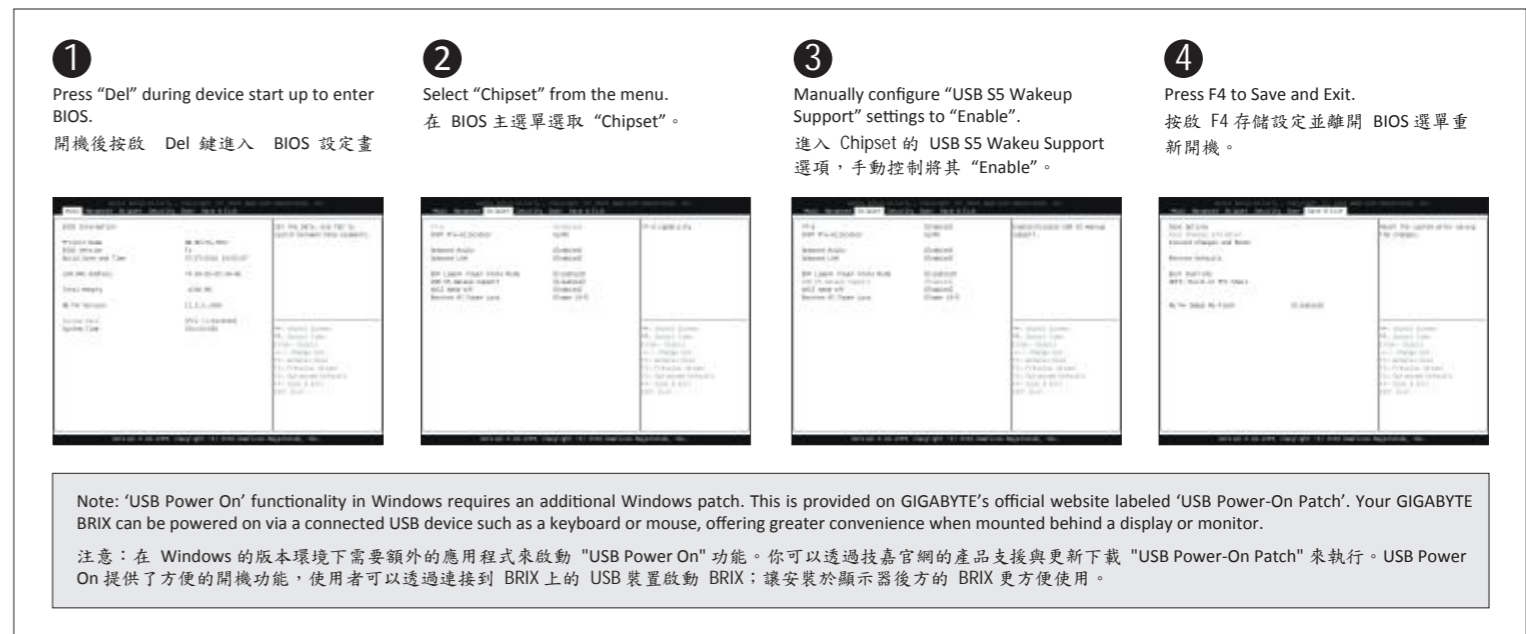

Note: 'USB Power On' functionality in Windows requires an additional Windows patch. This is provided on GIGABYTE's official website labeled 'USB Power-On Patch'. Your GIGABYTE BRIX can be powered on via a connected USB device such as a keyboard or mouse, offering greater convenience when mounted behind a display or monitor.  
 注意: 在 Windows 的版本環境下需要額外的應用程式來啟動 "USB Power On" 功能。你可以透過技嘉官網的產品支援與更新下載 "USB Power-On Patch" 來執行。USB Power On 提供了方便的開機功能，使用者可以透過連接到 BRIX 上的 USB 裝置啟動 BRIX；讓安裝於顯示器後方的 BRIX 更方便使用。

單元 Unit	鉛Lead (Pb)	汞Mercury (Hg)	鎘Cadmium (Cd)	六價鉻 Hexavalent chromium (Cr <sup>+6</sup> )	多溴聯苯 Polybrominated biphenyls (PBB)	多溴二苯醚 Polybrominated diphenyl ethers (PBDE)
電路板總成	—	○	○	○	○	○
外殼	○	○	○	○	○	○
電源供應器	—	○	○	○	○	○
線材	○	○	○	○	○	○
無線網路卡	—	○	○	○	○	○

備考1. “超出0.1 wt %” 及 “超出0.01 wt %” 係指限用物質之百分比含量超出百分比含量基準值。  
 Note 1: “Exceeding 0.1 wt %” and “exceeding 0.01 wt %” indicate that the percentage content of the restricted substance exceeds the reference percentage value of presence condition.

備考2. “○” 係指該項限用物質之百分比含量未超出百分比含量基準值。  
 Note 2: “○” indicates that the percentage content of the restricted substance does not exceed the percentage of reference value of presence.

備考3. “-” 係指該項限用物質為排除項目。  
 Note 3: The “-” indicates that the restricted substance corresponds to the exemption.