



# FreeSpace® 3 Business Music System

## APPLICATION NOTE

### How to Set Jumpers for Direct Stereo Operation

This application note illustrates how to use the FreeSpace® 3 system for direct (4 ohm) stereo operation.

Remove all jumper wires connected to the Acoustimass® module and connect your source as shown to the right:

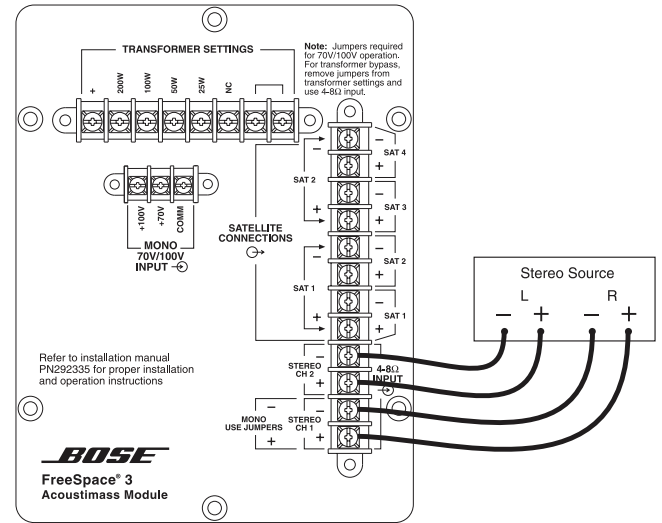

**Please note:** In setting up this operation, the following situation may occur: During system testing, while the source drives one channel only (shown right), a reduced output from the other channel is audible.

The FreeSpace system features a dual voice coil woofer. When a single channel receives a signal, the voice coil to the second channel becomes magnetically excited, resulting in a reduced output level from this channel. When the product operates in normal stereo mode, with both channels functioning, this signal is undetectable.

