

DS-VW765-LAND



Mounting Pattern  
200 x 200 up to  
700 x 400mm



Max Load  
125lb  
(56.8kg)



- Modular mount for unlimited video wall display configurations
- Displays and mounts sit flush against the wall for a clean side appearance
- Integrated cable management tie-backs make display-to-display cabling simple
- Included security hardware prevents the mount from extending out from the wall
- Adjustable VESA® mounting hole patterns in 100mm increments, starting at 200 x 200mm up to 700 x 400mm, additional patterns supported with adaptor plates

**SMARTMOUNT.**

# Full-Service Video Wall Mount - Landscape

FOR 40" TO 65" DISPLAYS

Peerless-AV's Full-Service Video Wall Mount is easy to configure, quick to install and a snap to maintain. Create any configuration imaginable, but leave the tedious calculations to the custom wall plate spacers. The mount's innovative design is loaded with time-saving features like no-tool-required micro-adjustments and easy-access to any display for quick serviceability.

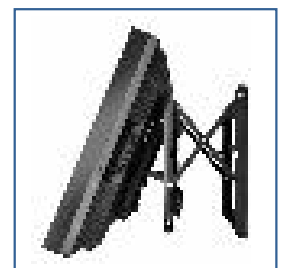
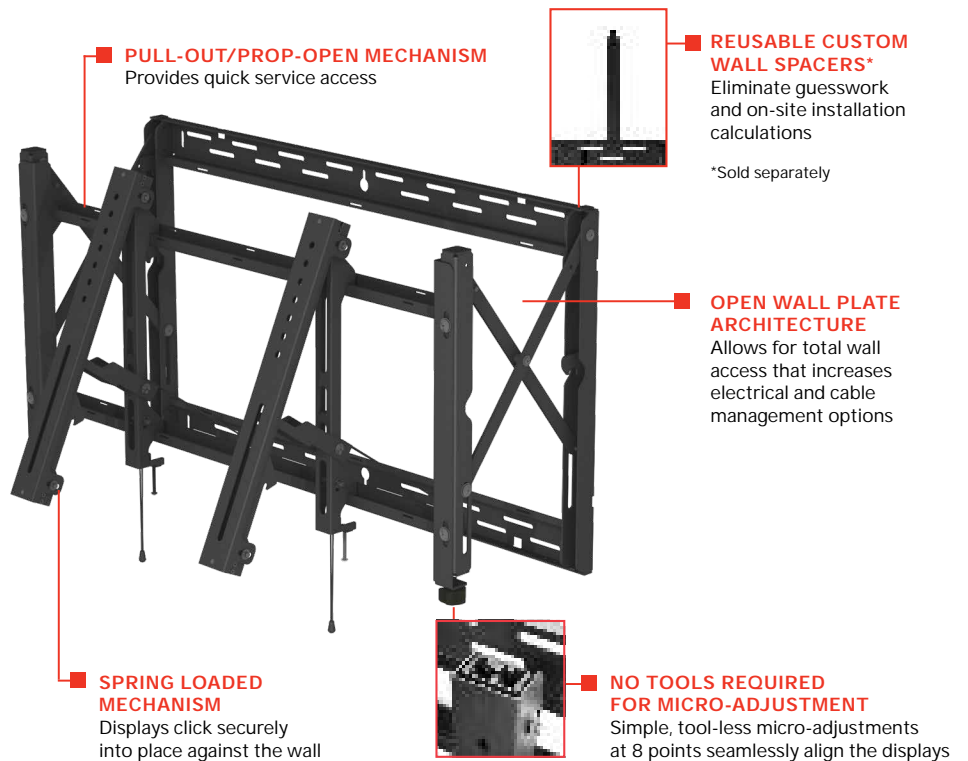

Full-Service Access



Please visit [peerless-av.com/en-us/patents](http://peerless-av.com/en-us/patents) for patent information.

✉ [info@peerless-av.com](mailto:info@peerless-av.com)  
🌐 [peerless-av.com](http://peerless-av.com)

**peerless-AV®**  
Driving Technology Through Innovation

# Model Number

**WARRANTY: Limited 5-year**

DS-VW765-LAND SmartMount® Full-Service Video Wall Mount for 40"-65" Displays - Landscape

## Product Specifications

	DIMENSIONS (W X H X D)	PRODUCT WEIGHT	LOAD CAPACITY	FINISH	AVAILABLE COLORS
DS-VW765-LAND	35.00" x 20.00" x 3.08"-3.83" (890 x 508 x 78-97mm)	33.0lb (15kg)	125lb (56.8kg)	Scratch Resistant Fused Epoxy	Black

## Package Specifications

	PACKAGE SIZE (W x H x D)	PACKAGE SHIP WEIGHT	PACKAGE UPC CODE	PACKAGE CONTENTS	UNITS IN PACKAGE
DS-VW765-LAND	37.13" x 22.25" x 4.25" (943 x 565 x 108mm)	37.95lb (17.25kg)	735029278771	Wall Mount Assembly, Mounting Attachment Rails & Fasteners	1

## Accessories

- DS-VWS###: Wall Plate Alignment Spacers
- DS-ACC765: Cable Release Kit
- DS-ACC770: Media Player Mounting Bracket
- PLP-V models: PLP Adaptor Plates

All dimensions = inch (mm)

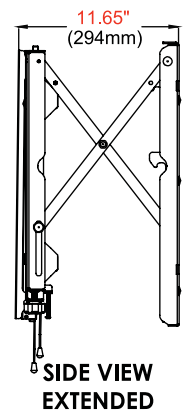
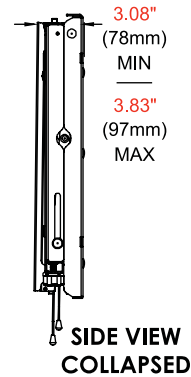
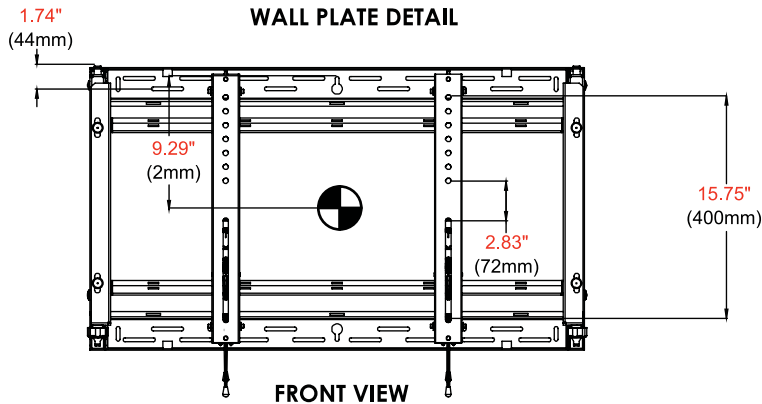
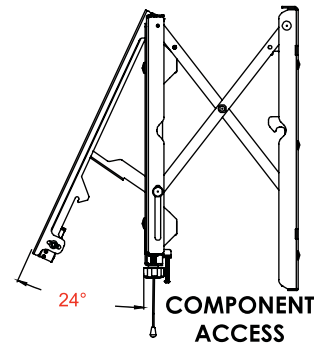
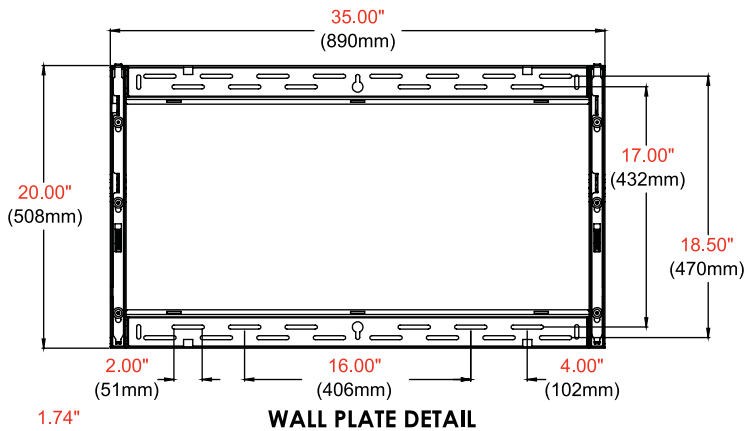

## Architect Specifications

The SmartMount® Full-Service Video Wall Mount - Landscape shall be Peerless-AV model DS-VW765-LAND and shall be located where indicated on the plans. It shall be constructed of heavy gauge steel. The finish shall be scratch resistant black fused epoxy. Assembly and installation shall be done according to instructions provided by the manufacturer.

Visit [peerless-av.com](http://peerless-av.com) to see the complete line of AV solutions from Peerless-AV, including outdoor displays, kiosks, digital audio, display mounts, projector mounts, carts/stands, and a full assortment of accessories.

**Peerless-AV**  
2300 White Oak Circle  
Aurora, IL 60502 USA  
**(800) 865-2112**  
**(630) 375-5100**  
**Fax: (800) 359-6500**

**Peerless-AV EMEA**  
Unit 3 Watford Interchange  
Colonial Way, Watford  
Herts, WD24 4WP  
United Kingdom  
**+44 (0) 1923 200100**  
**Fax: +44 (0) 1923 200101**

**Peerless-AV Latin America**  
Av. de las Industrias 413  
Parque Industrial Escobedo  
General Escobedo, N.L.,  
México, 66062  
**+52 (81) 8384-8300**  
**Fax: +52 (81) 8384-8360**

