

WITH STAND

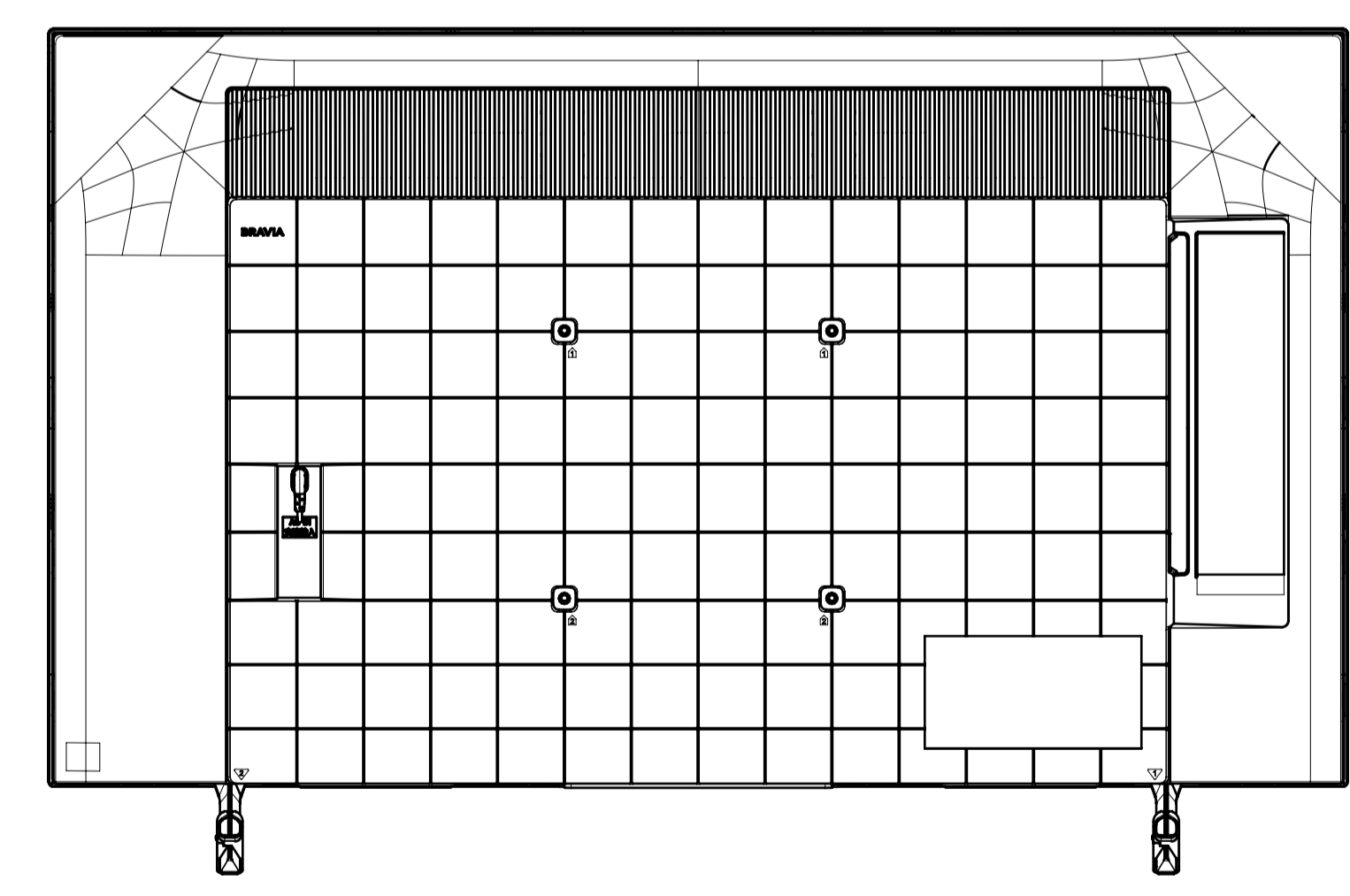
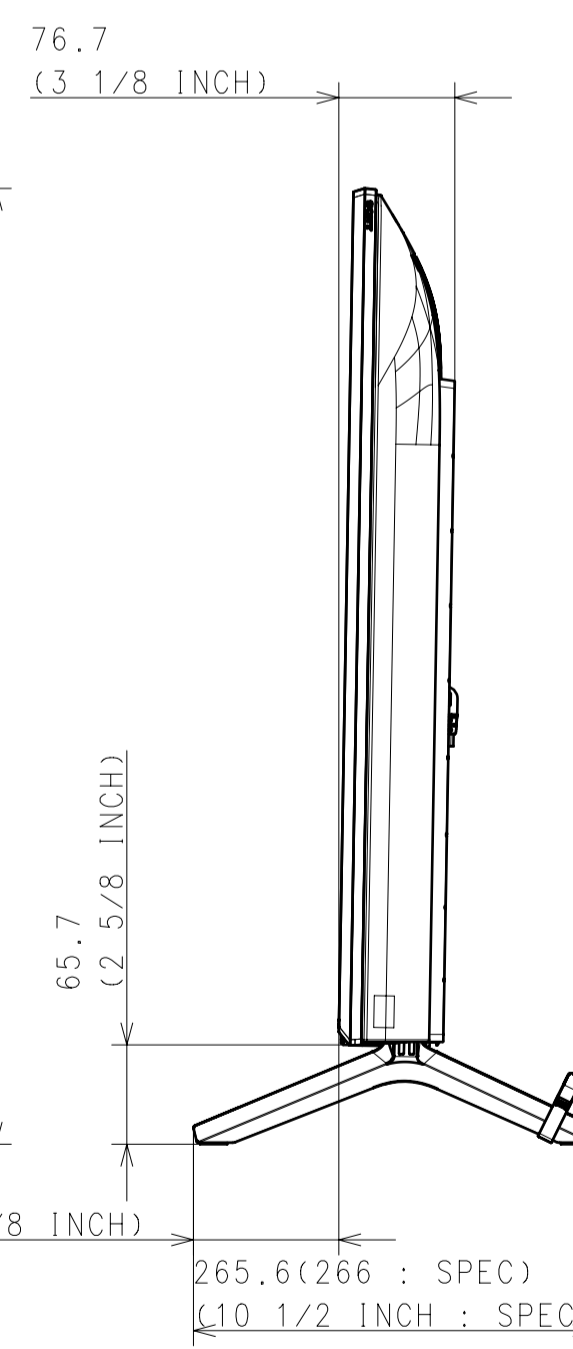
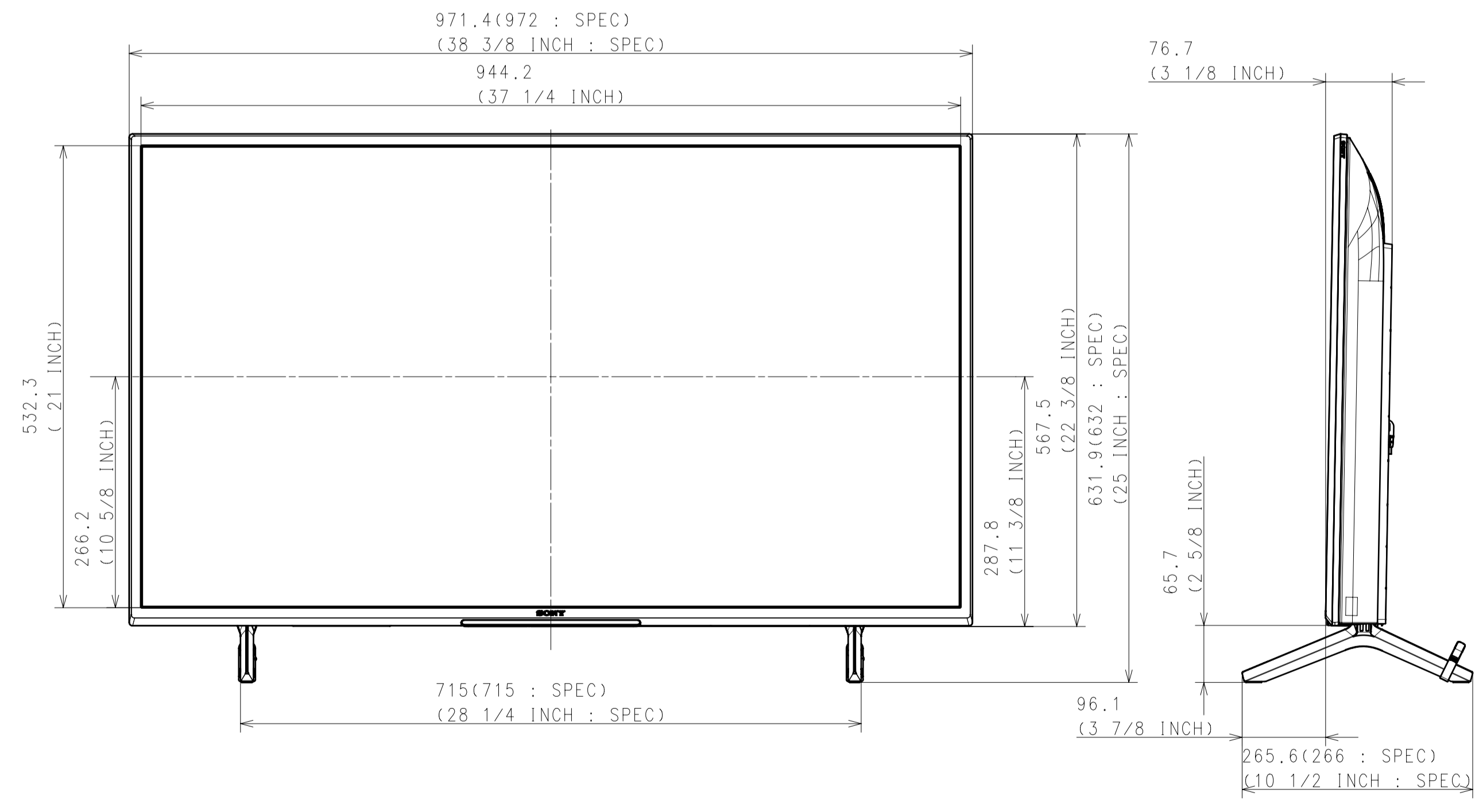
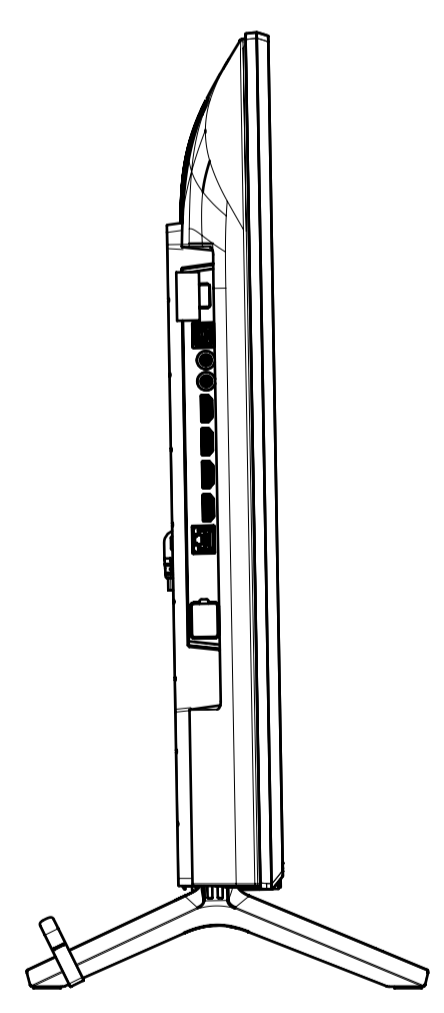
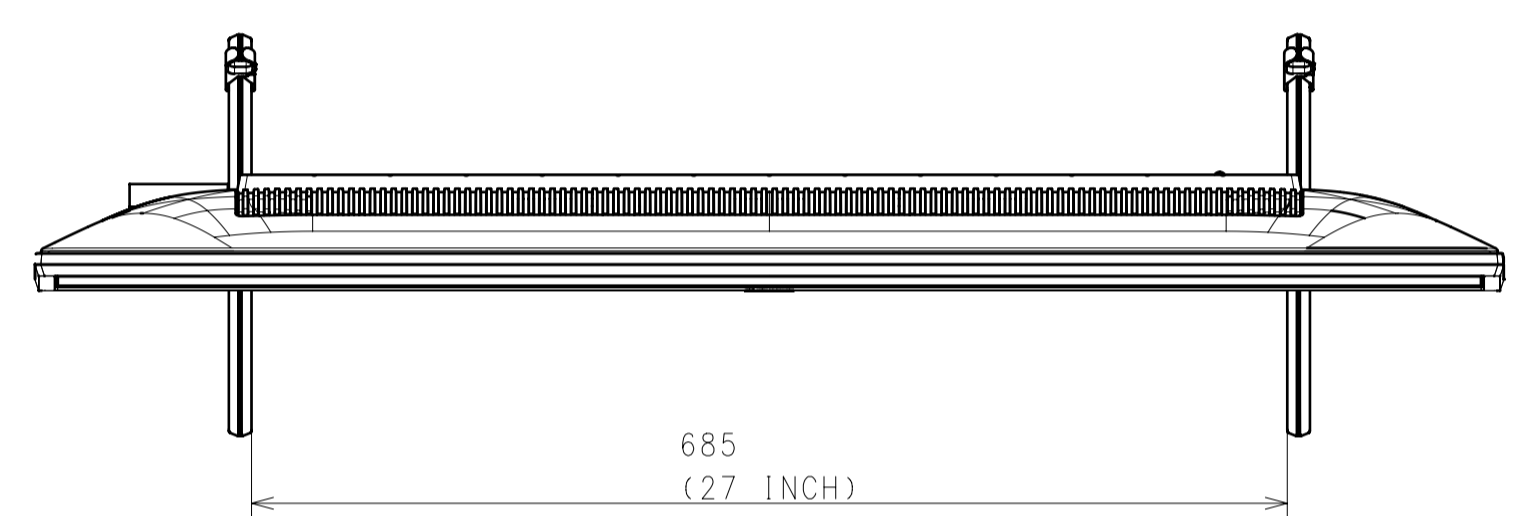

Area	JAPAN	EUROPE	GENERAL AREA	
Model Name	KJ-43X75WL	KD-43X75WL	KD-43X75WL	
SV No.	SV-41566	SV-41532	SV-41729	
DIMENSION	TV only (W x H x D)	97.2 x 56.7 x 7.0 cm	Approx. 97.2 x 56.7 x 7.0 cm	Approx. 97.2 x 56.7 x 7.0 mm
	TV only with camera (W x H x D)	-	-	-
	TV with Stand (Standard position) (W x H x D)	97.2 x 63.2 x 26.6 cm	Approx. 97.2 x 63.2 x 26.6 cm	Approx. 97.2 x 63.2 x 26.6 mm
	TV with Stand (Narrow position) (W x H x D)	-	-	-
	TV with Stand (Soundbar position) (W x H x D)	-	-	-
	TV with Stand (Front position style) (W x H x D)	-	-	-
	TV with Stand (Back position style) (W x H x D)	-	-	-
	TV with Floor Stand (W x H x D)	-	-	-
	Stand Width (Standard position)	71.5 cm	Approx. 71.5 cm	Approx. 715 mm
	Stand Width (Narrow position)	-	-	-
	Stand Width (Soundbar position)	-	-	-
	Stand Width (Front position style)	-	-	-
	Stand Width (Back position style)	-	-	-
	Floor Stand Width	-	-	-
VESA Hole Pitch	20.0 x 20.0 cm	20.0 x 20.0 cm	200 x 200 mm	
WEIGHT	TV Only	9.3 kg	Approx. 9.3 kg	Approx. 9.3 kg
	TV with Stand (Standard position)	9.5 kg	Approx. 9.5 kg	Approx. 9.5 kg
	TV with Stand (Narrow position)	-	-	-
	TV with Stand (Soundbar position)	-	-	-
	TV with Stand (Front/Back position style)	-	-	-
	TV with Floor Stand	-	-	-
	Floor Stand weight (Supply)	-	-	-
W-M't Br. Weight (Supply)	-	-	-	
Remarks				

Purchase recycled resins and wire rods only from the business partners that Sony approves as Green Partners.
再生樹脂・銅線材はグリーンパートナー認定品から調達すること。

DATE OF ISSUE 2023.01.03	DOCUMENT TYPE ASSEMBLY DRAWING
TOLERANCE (JIS 0 00150 0015)	FINISH(COLOR)
REVISION	DATE
SUFFIX AREA NO.	RELEASE NO.
HISTORY	LEGAL OWNER
RESPONSIBLE DEPARTMENT	ORIGINAL MODEL
PLANNED BY	CHECKED BY
APPROVED BY	SCALE
DATE	1:5
TENTATIVE MODEL	DESCRIPTIONS
43(X75WL) EXTERIOR VIEW	43(X75WL) EXTERIOR VIEW
DESCRIPTIONS	DESCRIPTIONS
43(X75WL) EXTERIOR VIEW	43(X75WL) EXTERIOR VIEW
SIZE	UNIT
A1	mm
PREL. METHOD	FIG. NO.
SIZE	SUFFIX
REV. NO.	REV. NO.
1/3	1/3

18.08 F spec - D12

WITHOUT STAND

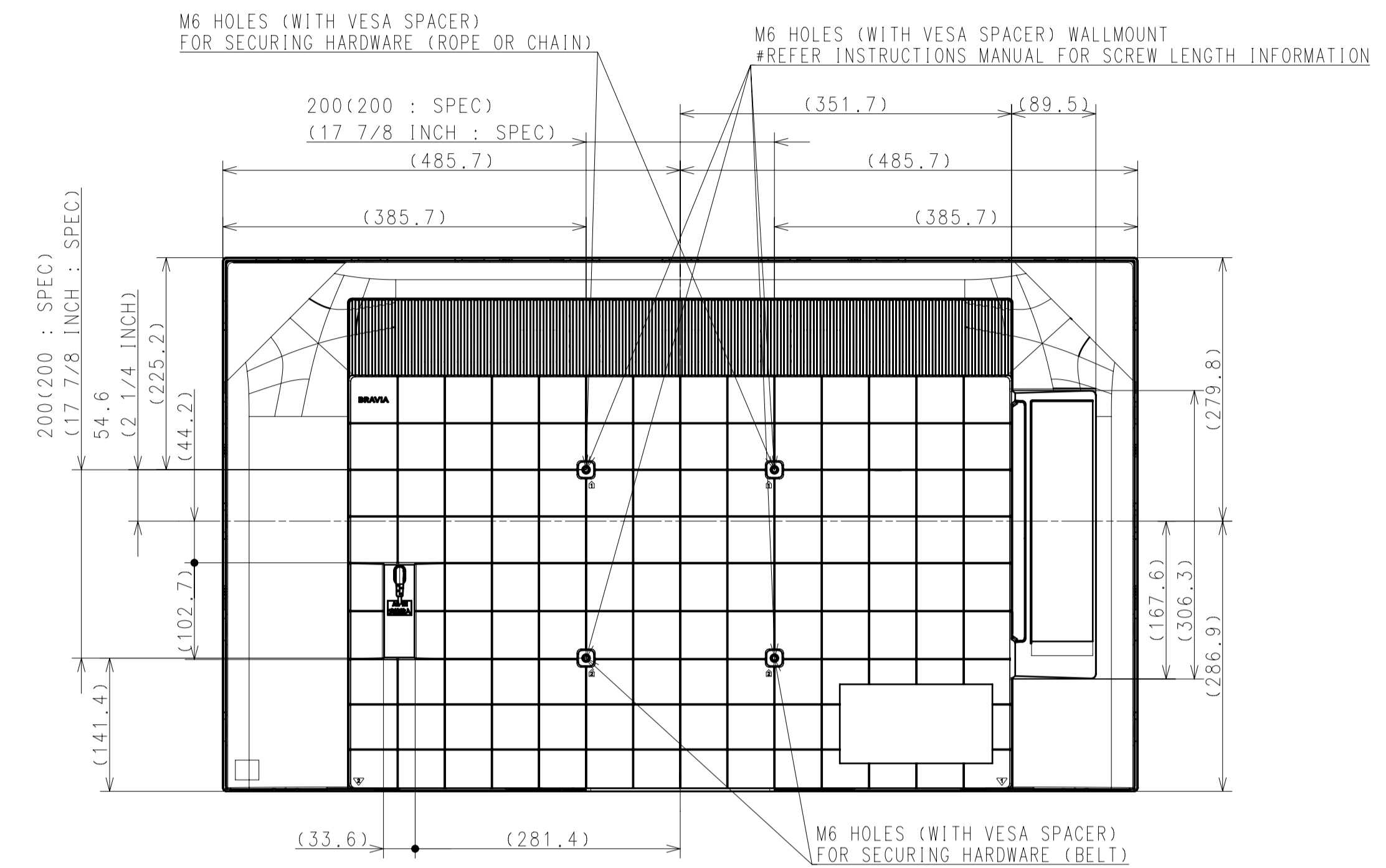
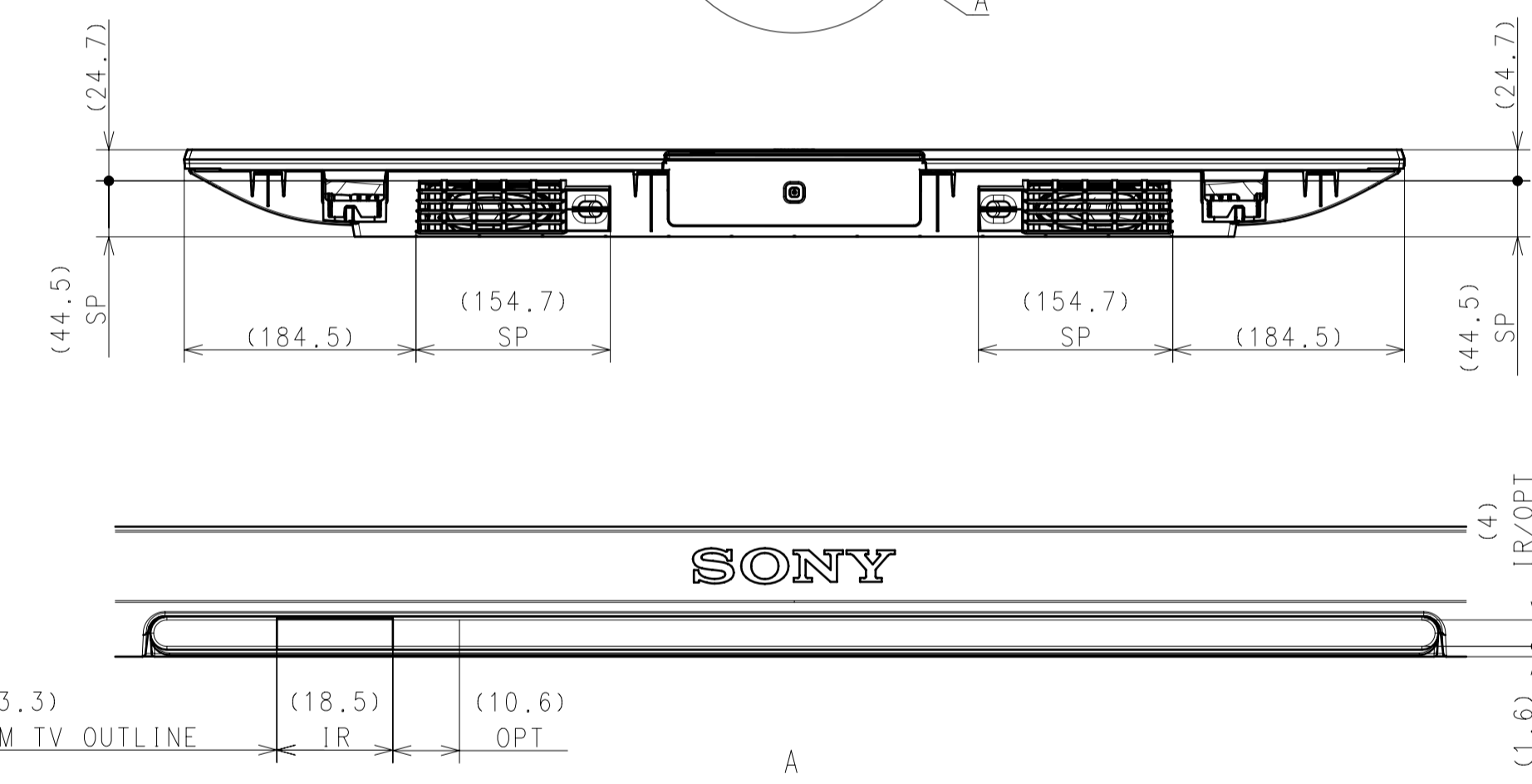
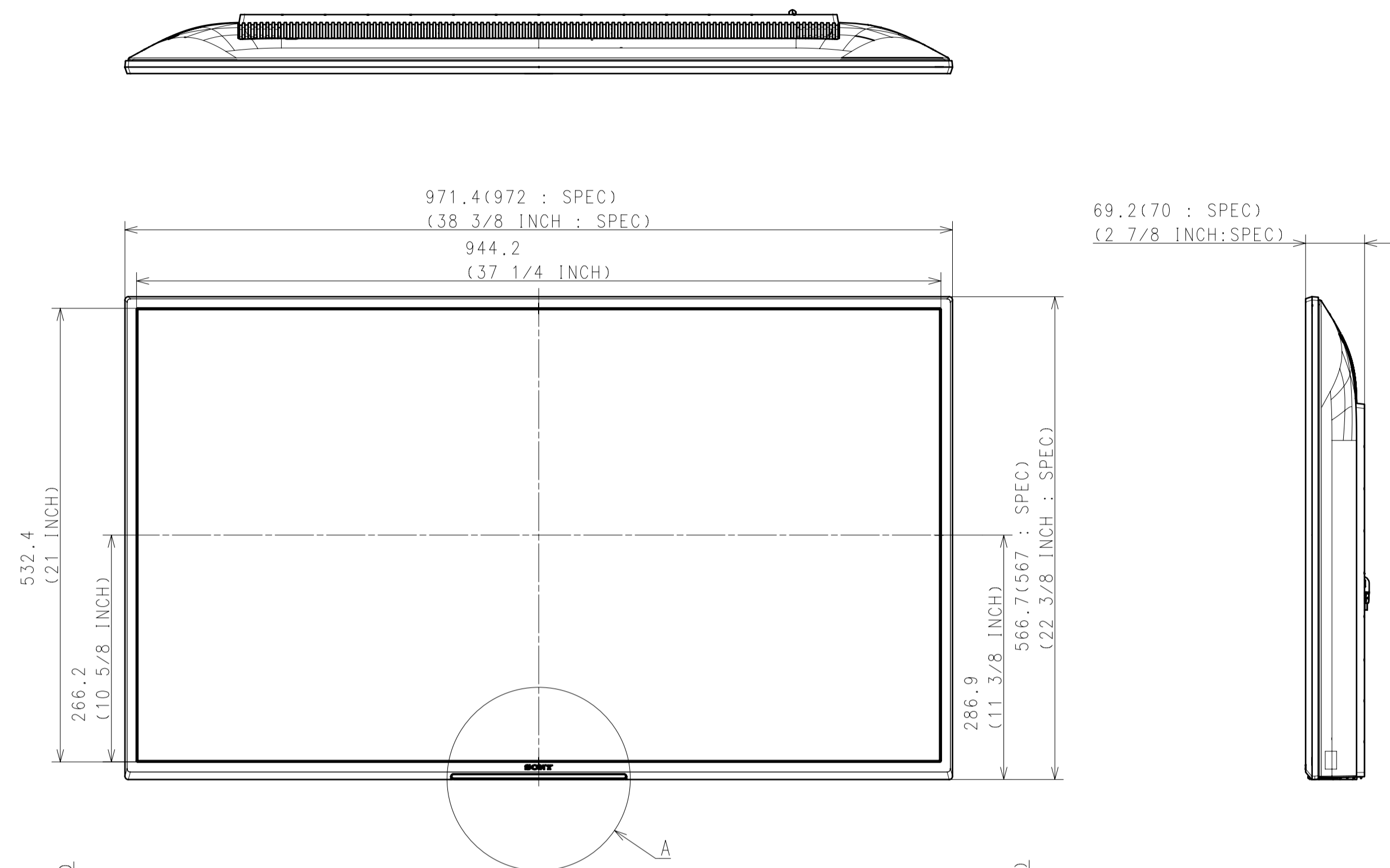

FOR GENERAL AREA, JAPAN

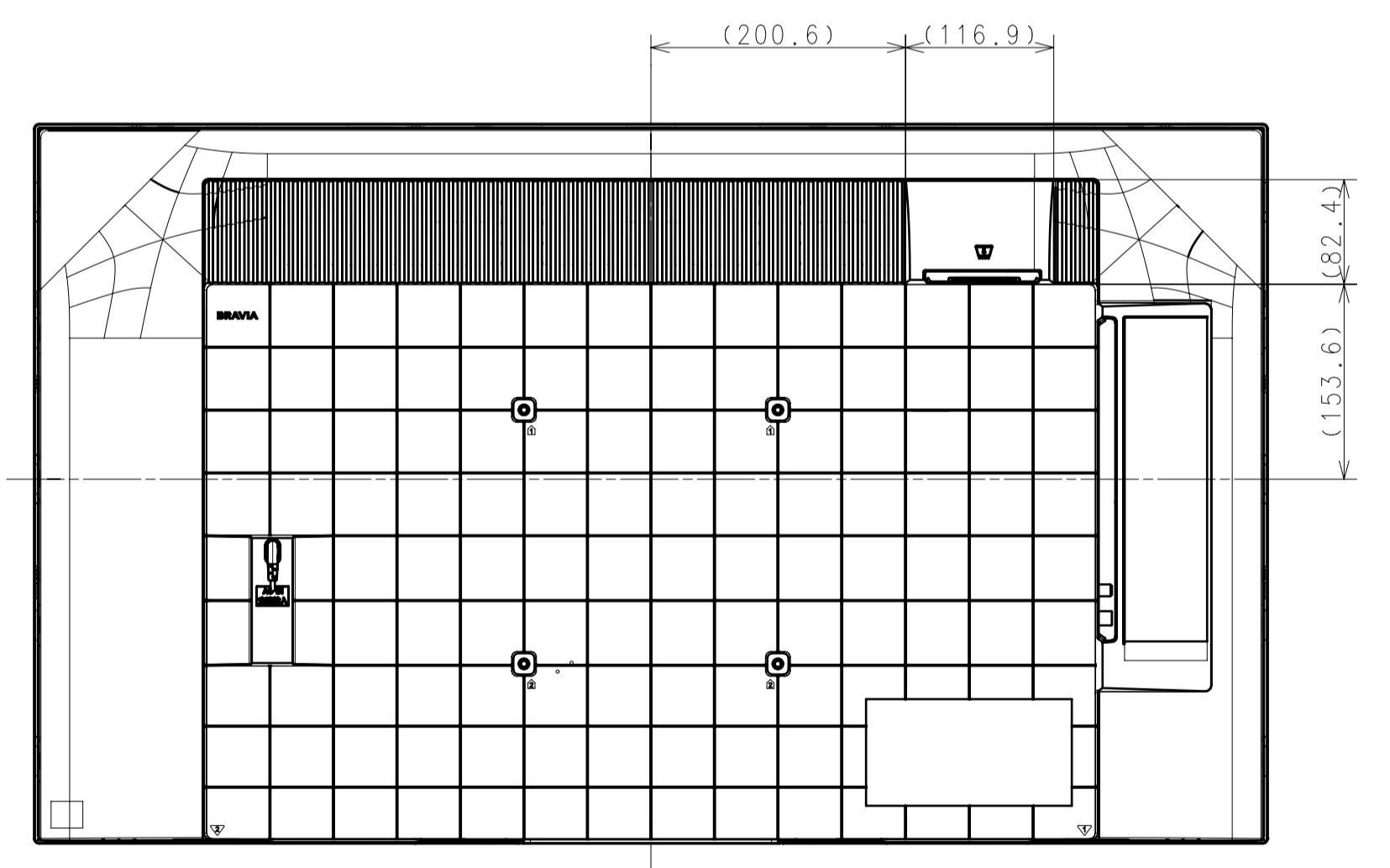

FOR EUROPE

DESCRIPTION1 43(X75WL) EXTERIOR VIEW	LEGAL OWNER Sony Corporation	SCALE 1:5
DESCRIPTION2 43(X75WL) EXTERIOR VIEW	PART NO.	SHEET/PAGES 2 / 3

SU-WL450

STANDARD

SLIM

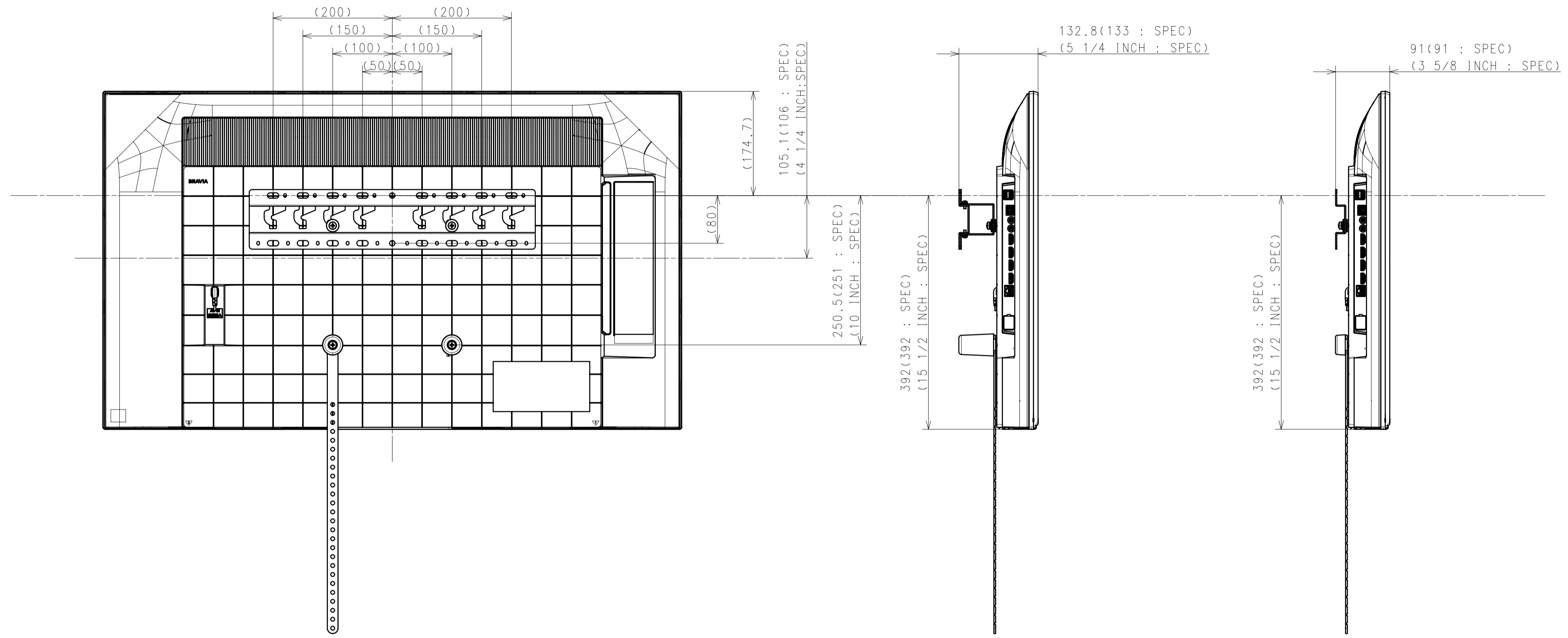

DRAWING

SONY STANDARD

DESCRIPTION 1	LEGAL OWNER	SCALE
43(X75WL) EXTERIOR VIEW	Sony Corporation	1:5
DESCRIPTION 2	PART NO.	SHEET/PAGES
43(X75WL) EXTERIOR VIEW		3 / 3