

Counter Flex

Assembly Instructions

Tools Required:

- Socket Driver

Sheet Code: BP-IM-039_REV2

Release Date: 28/10/2019

Copyright 2016 Spotspot Ltd. (T/A Bouncepad) all rights reserved. Confidential, no part of this publication may be reproduced or transmitted in any form without the written permission of the copyright holder.

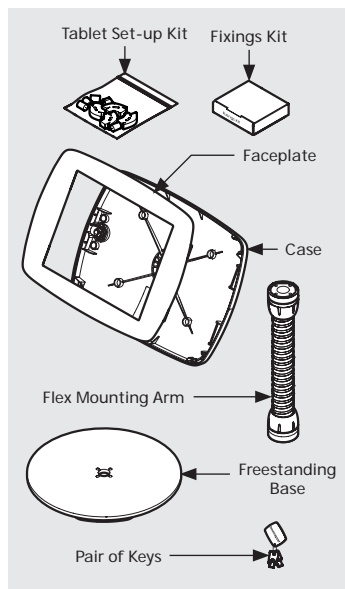

In the Box

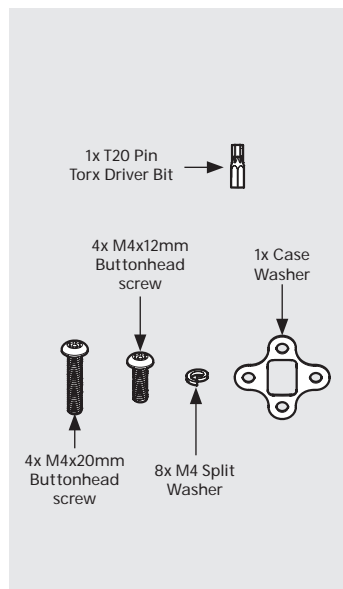

Fixings List

* Due to the modular nature of our product range you may receive additional fixings in the fixings kit

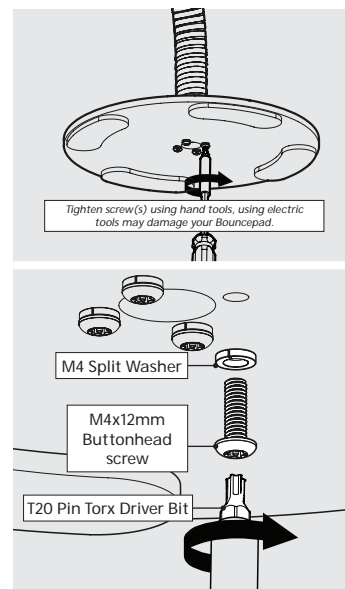

1 Locate & secure the Flex Mounting Arm to the Freestanding Base.

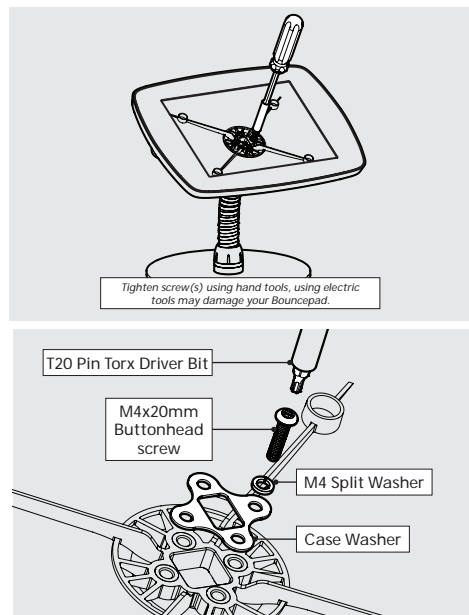

2 Attach the Bouncepad Case to its Mounting Arm. Take care to ensure correct & full thread engagement.

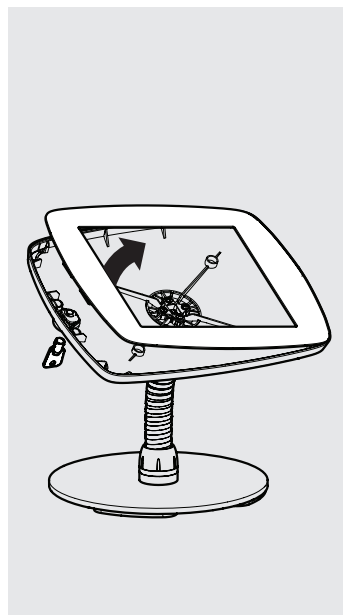

3 Unlock & remove the Faceplate from the Bouncepad Case.

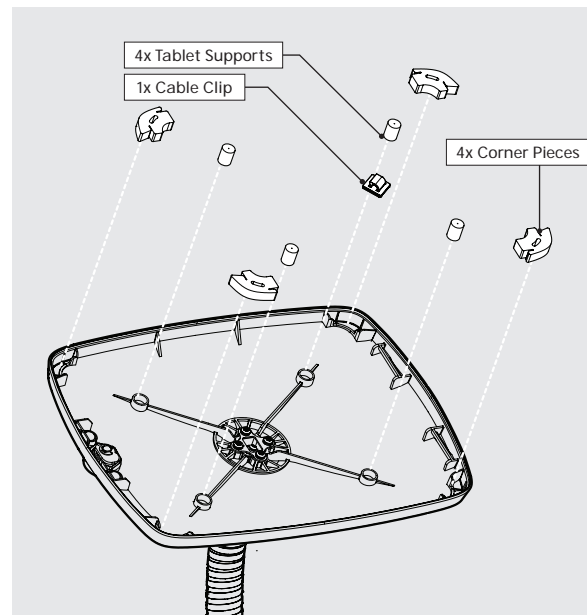

4 Install the Tablet Setup Kit. Each kit is specific per tablet device and Bouncepad Case.

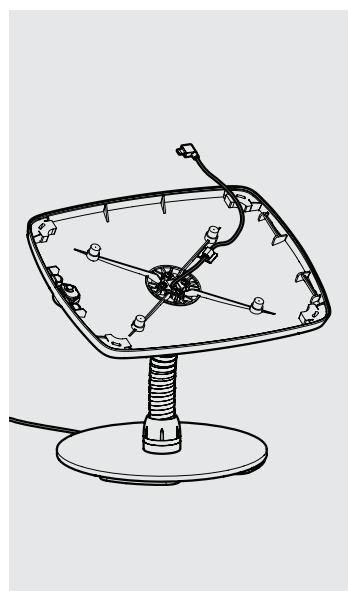

5 Feed the tablet cable through the Bouncepad Case & mounting arm

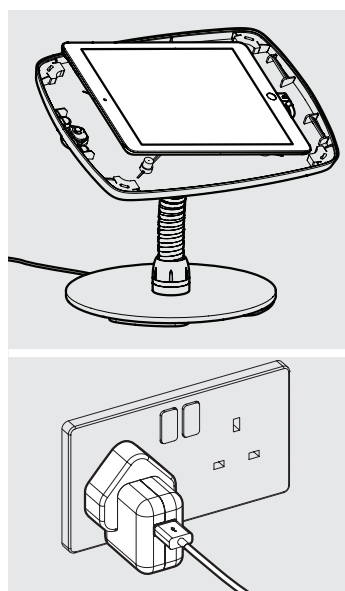

6 Place the tablet into the Case and connect to power.

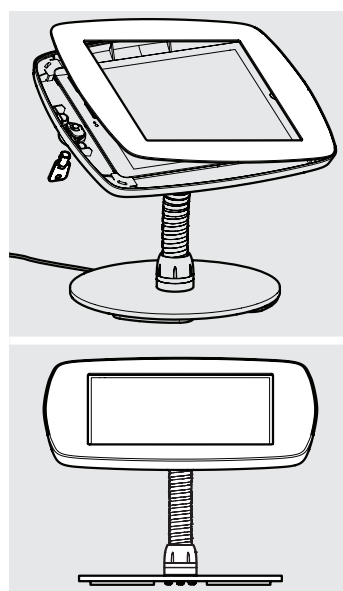

6 Locate and lock the Faceplate onto the Bouncepad Case.



7 Installation is now complete.