

Area	JAPAN	EUROPE	GENERAL AREA	
Model Name	KJ-50X75WL	KD-50X75WL	KD-50X75WL	
SV No.	SV-41565	SV-41531	SV-41728	
DIMENSION	TV only (W x H x D)	112.6 x 65.3 x 7.0 cm	Approx. 112.6 x 65.3 x 7.0 cm	Approx. 1126 x 653 x 70 mm
	TV only with camera (W x H x D)	-	-	-
	TV with Stand (Standard position) (W x H x D)	112.6 x 71.8 x 26.7 cm	Approx. 112.6 x 71.8 x 26.7 cm	Approx. 1126 x 718 x 267 mm
	TV with Stand (Narrow position) (W x H x D)	-	-	-
	TV with Stand (Soundbar position) (W x H x D)	-	-	-
	TV with Stand (Front position style) (W x H x D)	-	-	-
	TV with Stand (Back position style) (W x H x D)	-	-	-
	TV with Floor Stand (W x H x D)	-	-	-
	Stand Width (Standard position)	71.5 cm	Approx. 71.5 cm	Approx. 715 mm
	Stand Width (Narrow position)	-	-	-
	Stand Width (Soundbar position)	-	-	-
	Stand Width (Front position style)	-	-	-
Stand Width (Back position style)	-	-	-	
Floor Stand Width	-	-	-	
VESA Hole Pitch	20.0 x 20.0 cm	20.0 x 20.0 cm	200 x 200 mm	
WEIGHT	TV Only	12.1 kg	Approx. 12.1 kg	Approx. 12.1 kg
	TV with Stand (Standard position)	12.3 kg	Approx. 12.3 kg	Approx. 12.3 kg
	TV with Stand (Narrow position)	-	-	-
	TV with Stand (Soundbar position)	-	-	-
	TV with Stand (Front/Back position style)	-	-	-
	TV with Floor Stand	-	-	-
Floor Stand weight (Supply)	-	-	-	
W-M't Br. Weight (Supply)	-	-	-	
Remarks				

WITH STAND

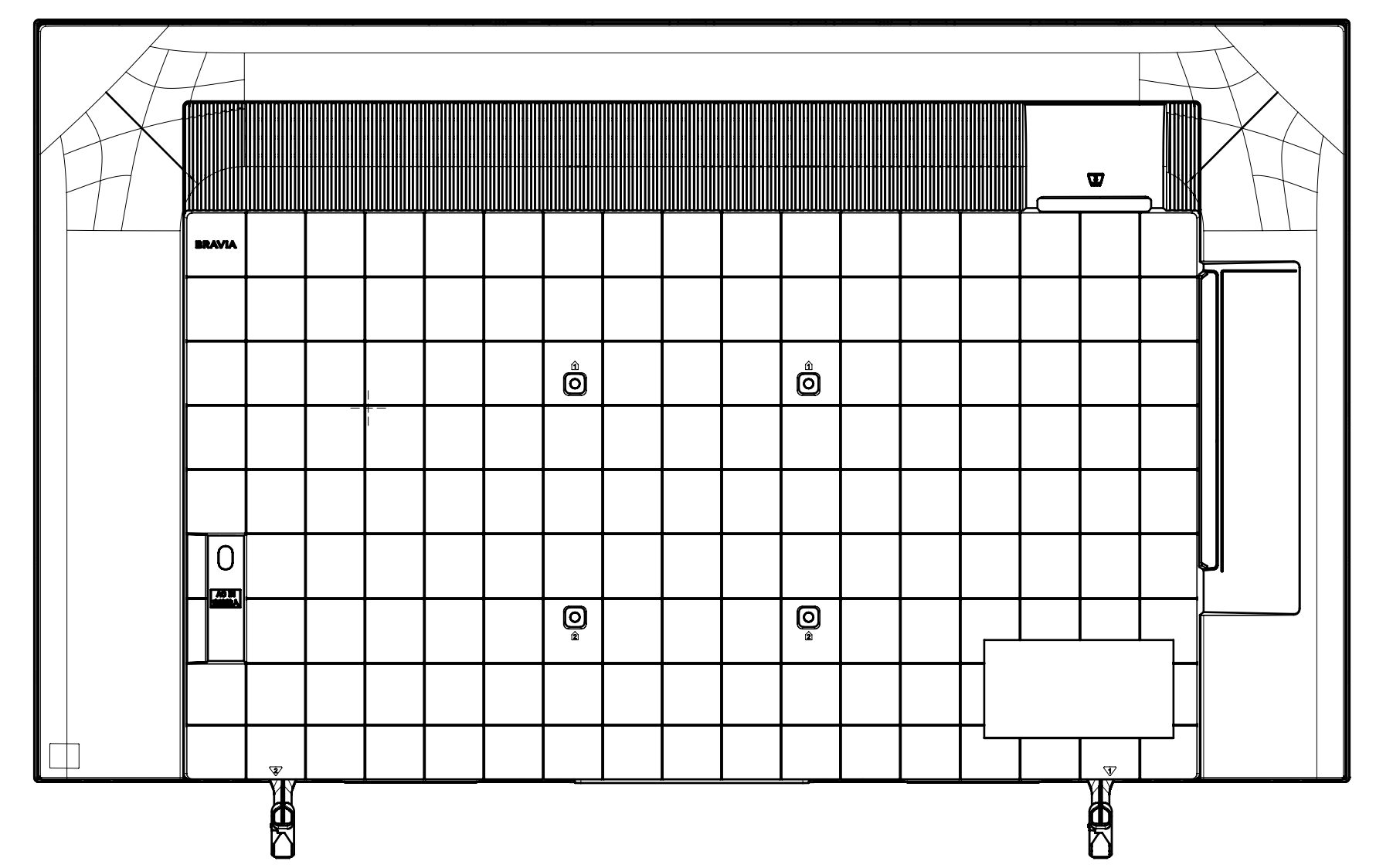
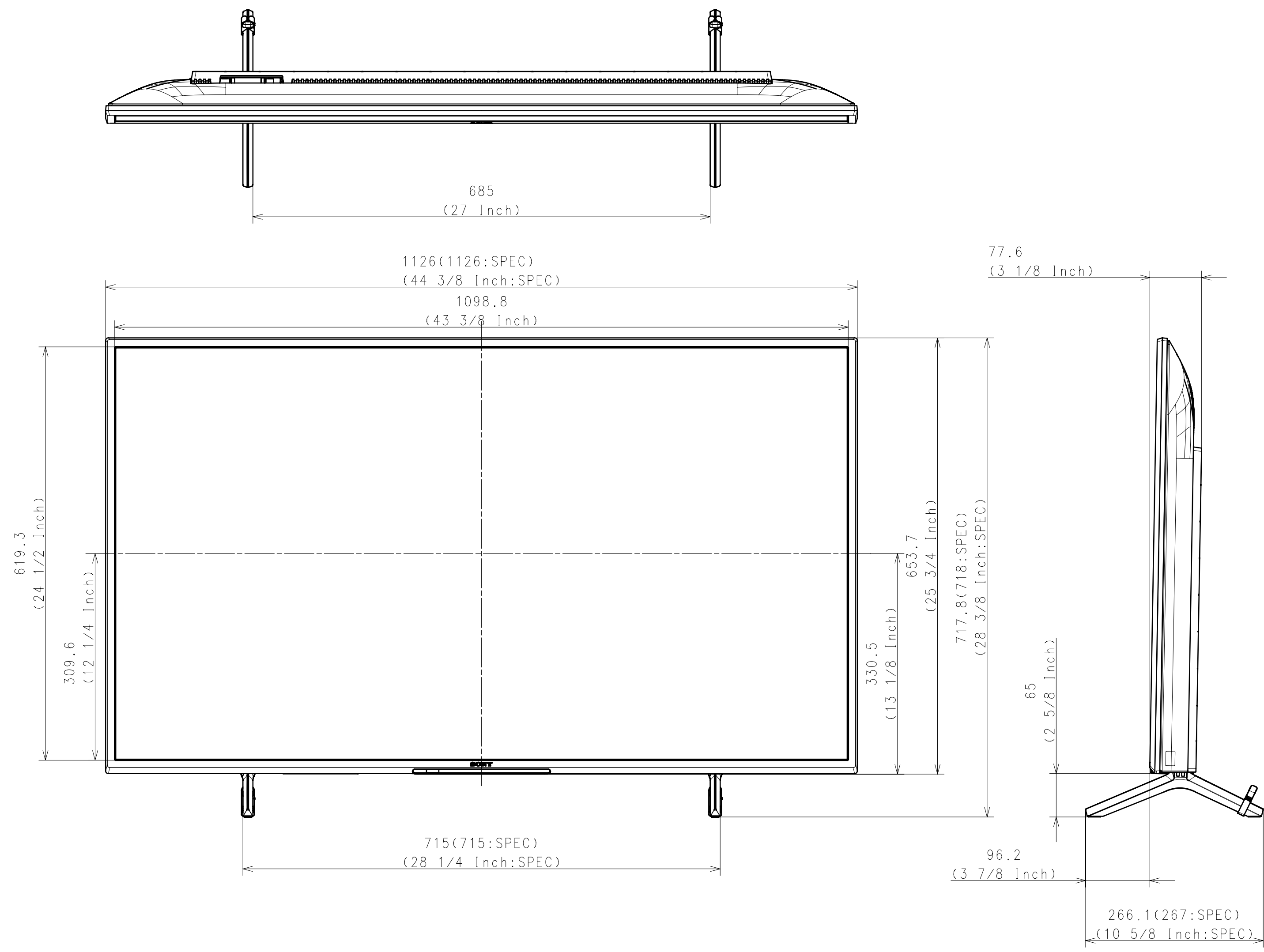

Purchase recycled resins and wire rods only from the business partners that Sony approves as Green Partners.  
再生樹脂・銅線材はグリーンパートナー認定品から調達すること。

DATE OF ISSUE 2022.12.29	DOCUMENT TYPE ASSEMBLY DRAWING	GENERAL TOLERANCE	(JIS 0 001/0.01/0.05)
HISTORY COUNT	SUFFIX REV. NO.	RELEASE NO. DATE	REVISION
LEGAL OWNER Sony Corporation	RESPONSIBLE DEPARTMENT PANEL & MECHANICAL DESIGN	ORIGINAL MODEL 50(X75WL) EXTERIOR VIEW	DESCRIPTION 50(X75WL) EXTERIOR VIEW
PLANNED BY	DRAWN BY	CHECKED BY	APPROVED BY
SCALE 1:5	TENTATIVE MODEL	SIZE A1	UNIT mm
PAGE NO.	SUFFIX	REV. NO.	SHEET/PAGES 1/3

WITHOUT STAND

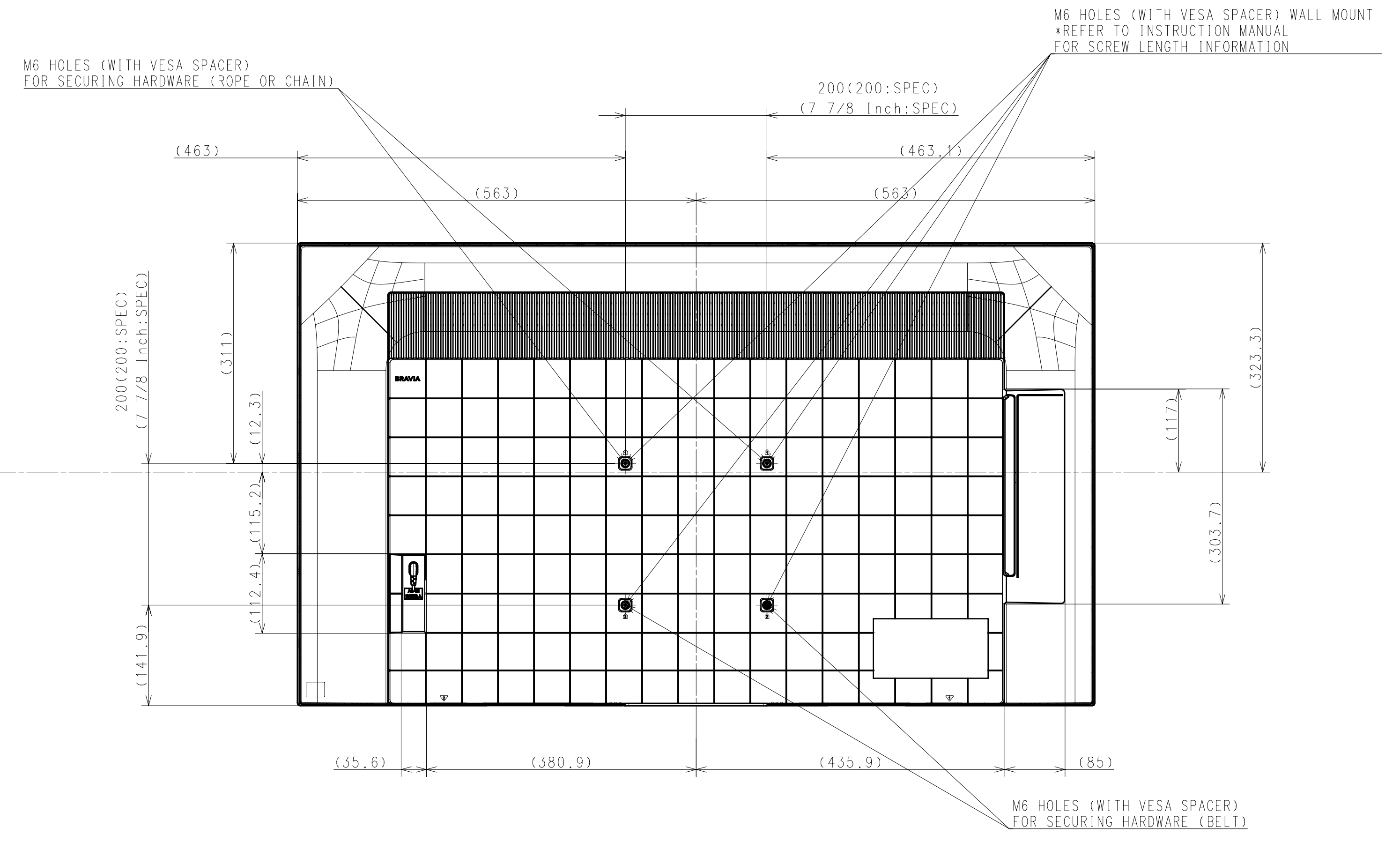
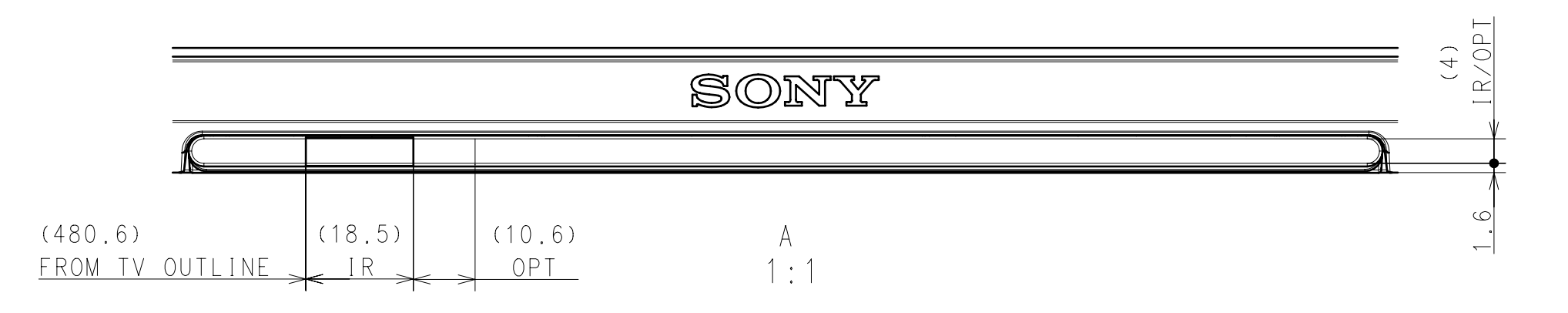
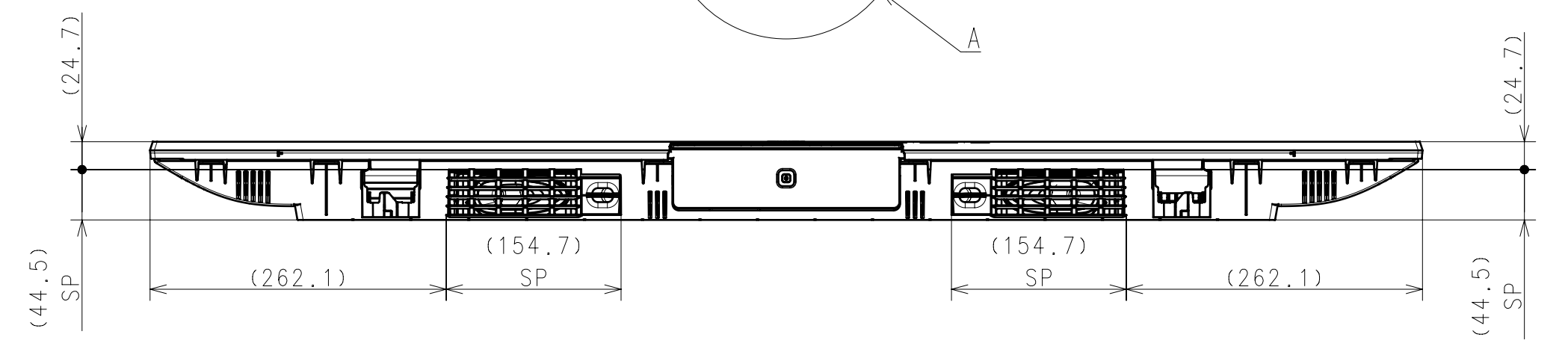
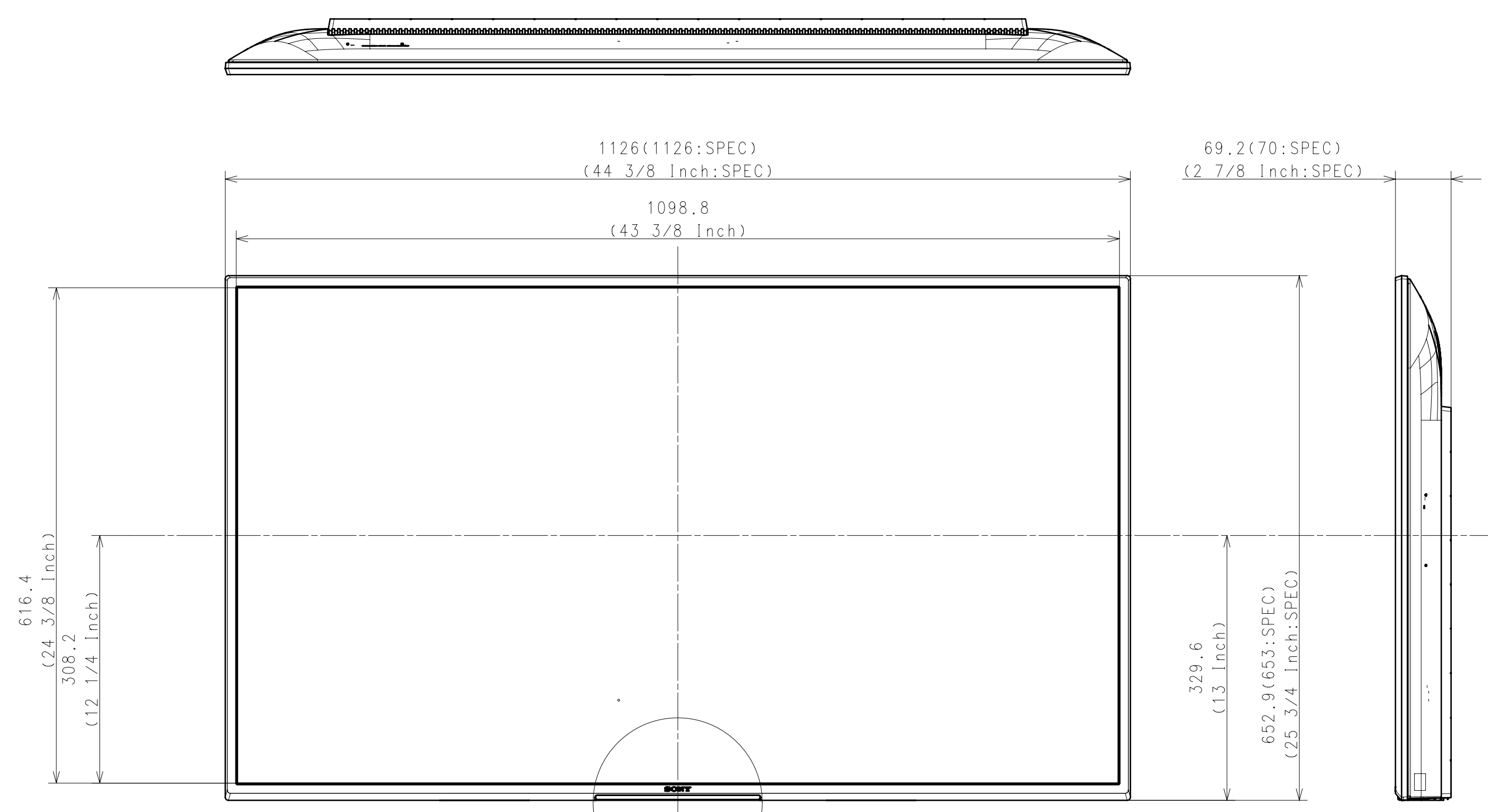

FOR. GENERAL AREA, JAPAN

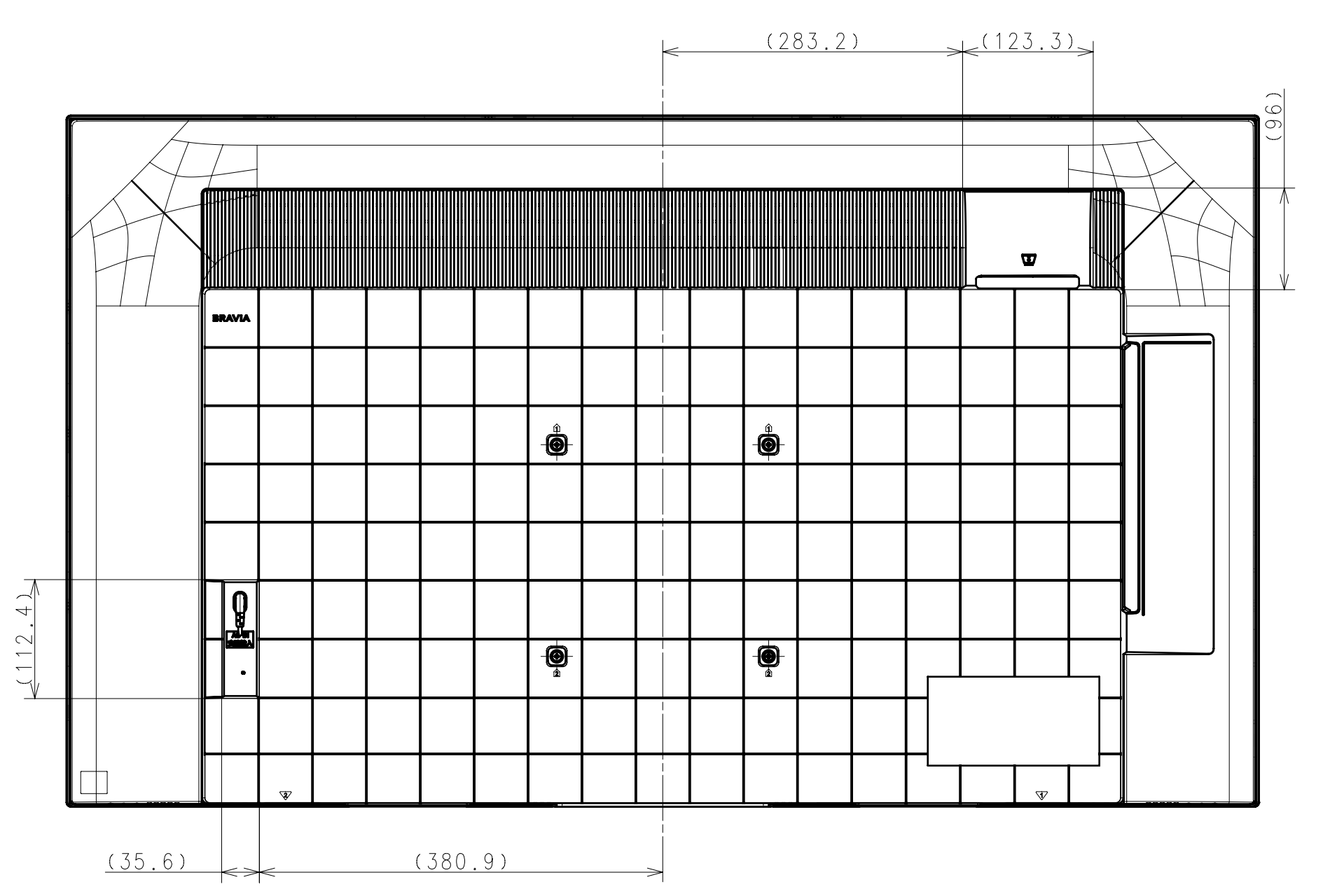

FOR. EUROPE

DESCRIPTION 1	LEGAL OWNER	SCALE
50(X75WL) EXTERIOR VIEW	Sony Corporation	1:1
DESCRIPTION 2	PART NO.	SHEET/PAGES
50(X75WL) EXTERIOR VIEW		2 / 3

SU-WL450

STANDARD

SLIM

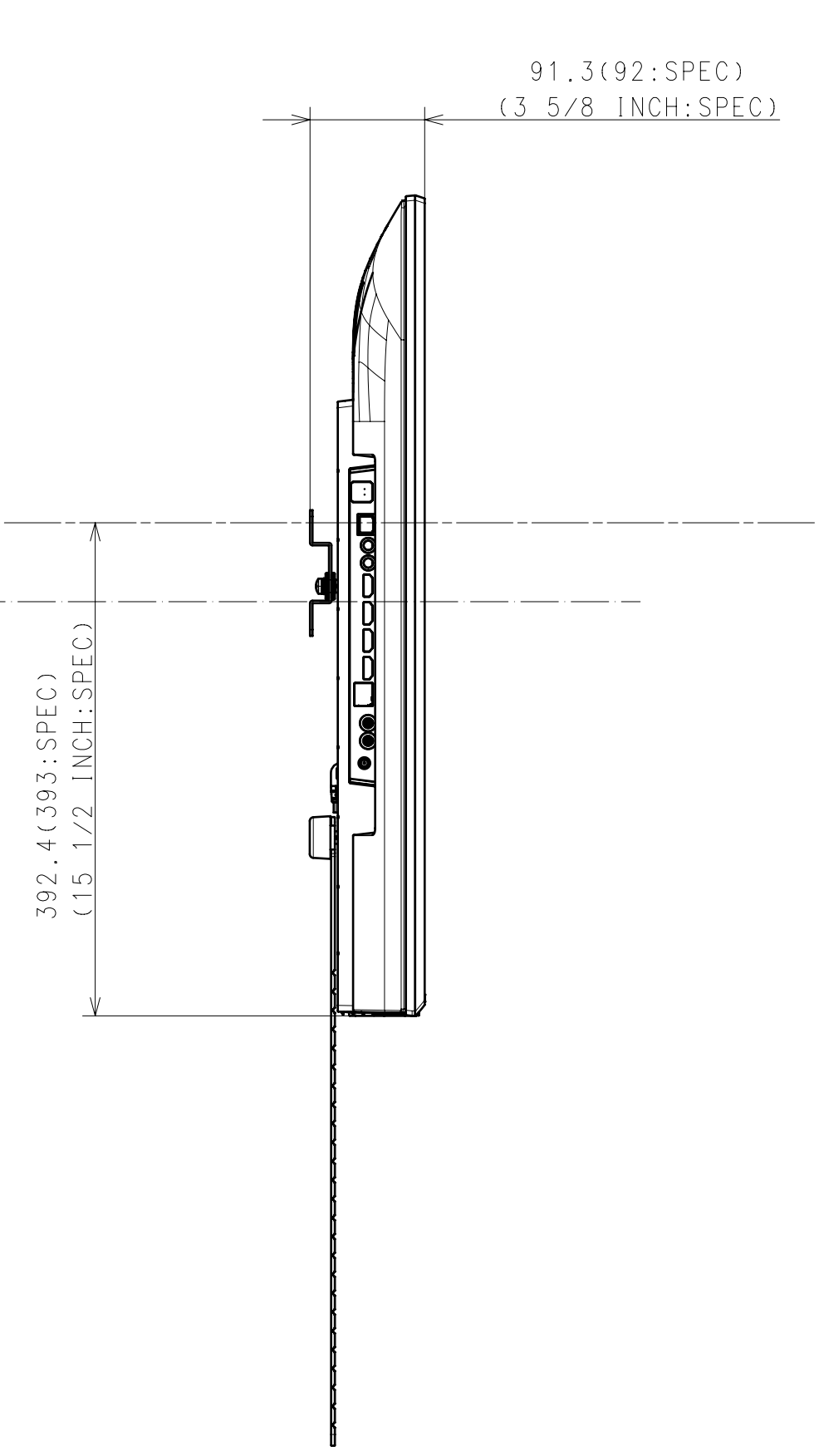
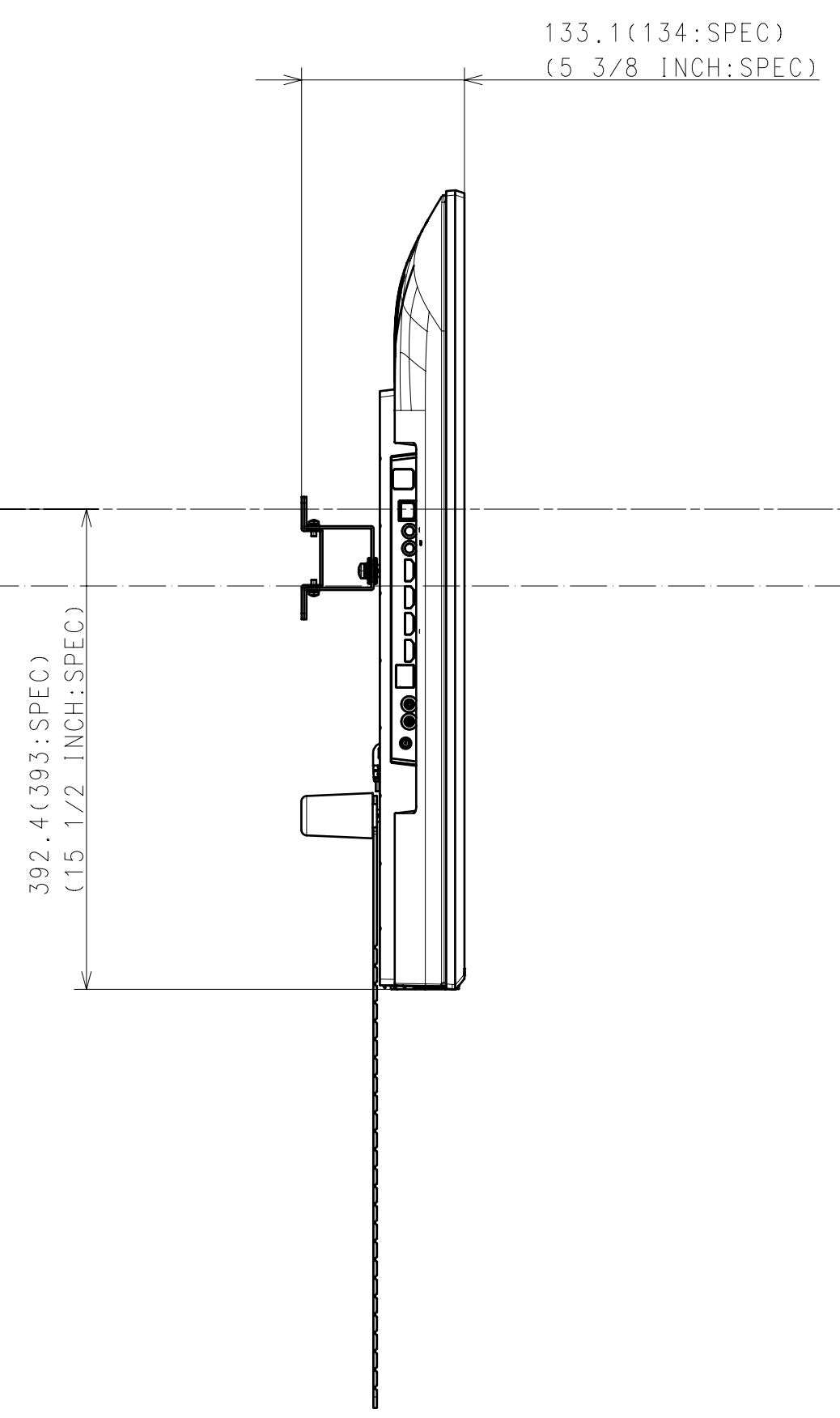
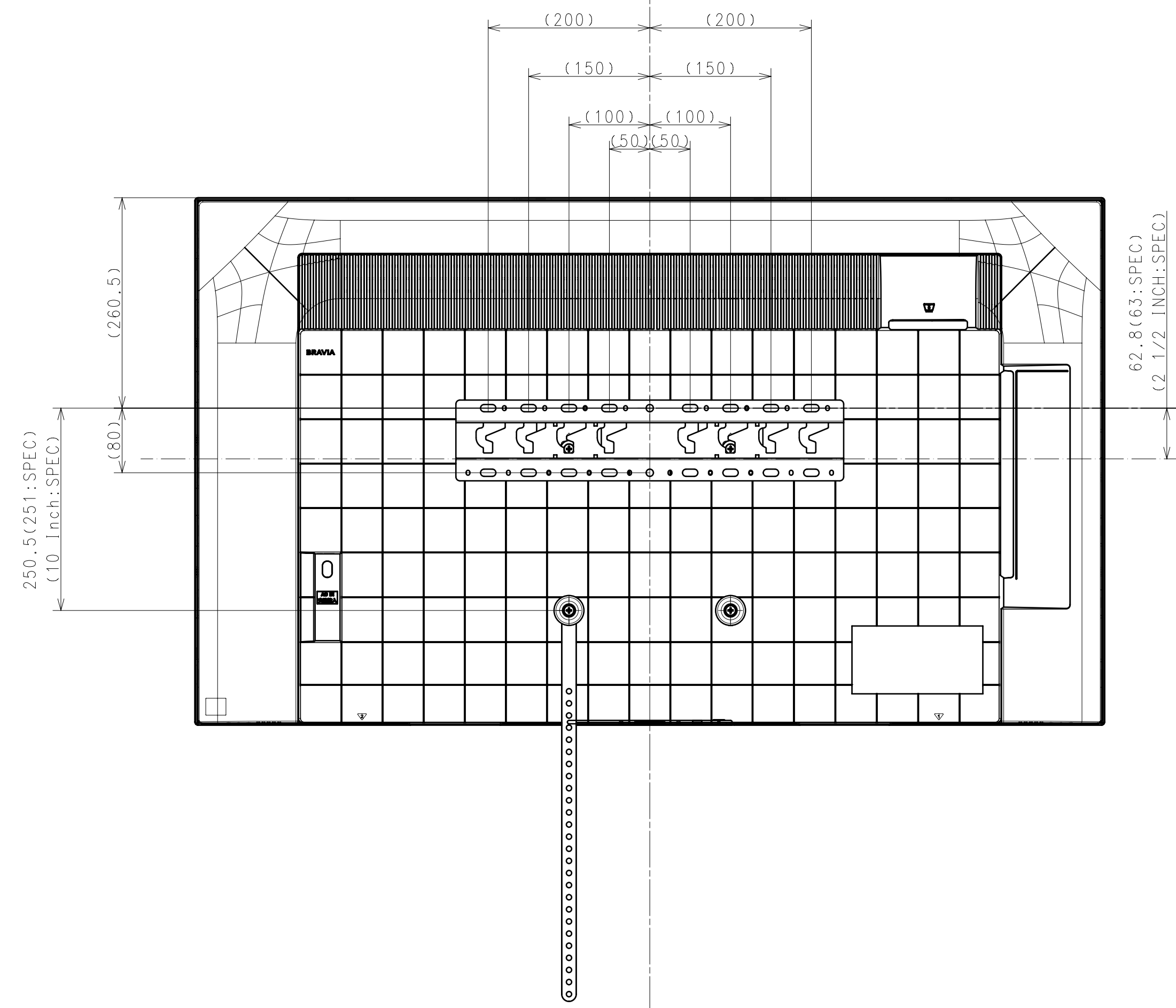

SONY STANDARD

DESCRIPTION 1	LEGAL OWNER	SCALE
50(X75WL) EXTERIOR VIEW	Sony Corporation	1:1
DESCRIPTION 2	PART NO.	SHEET/PAGES
50(X75WL) EXTERIOR VIEW		3 / 3