

Wall Mount for Era 300

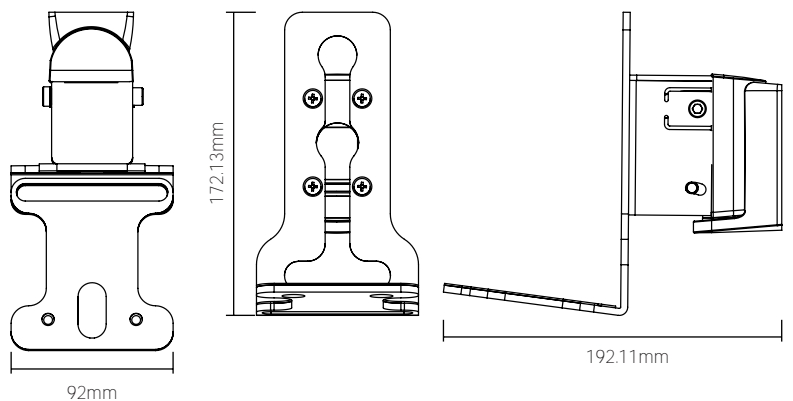

With a bespoke, precision-engineered design, the Flexson Wall Mount holds your Sonos Era 300 speaker securely, while being built for easy fitting that makes it simple for just about anyone to work with. And once it's affixed to the wall, you can enjoy the unique mechanism that allows your speaker to be tilted downwards 20°, as well as the ability to swivel up to 60° (30° left and 30° right). You can even invert your speaker to be held upside down within the Wall Mount, so its controls and microphone are easily accessible at any angle.



- Quick and easy assembly
- Designed to colour match your Sonos speaker
- Crafted specifically to support the Sonos Era 300 speaker
- Can be inverted to hold the speaker upside down
- Unique tilting mechanism and 60° swivel
- Precision engineered for quality
- Fixing hardware included for brick/masonry and brick/studwork

	White		Black	
EU Product Code	FLXE300WM1011		FLXE300FS1021	
EU EAN-13 Barcode	5057964002781		5057964002798	
UK, European and US (SRP)	£54.99	€64.99	\$64.99	
Product Specifications	Height	Width	Depth	Weight
Product Size (mm)	172.13mm	92mm	192.11mm	
Carton Dimensions (mm)	177mm	204mm	97mm	0.975kg
Carton Contents	1 x mount, 1 x instructions, 1 x fixings			
Country of Manufacture	China	Outer Carton Quantity	4	