







3710

Montageanleitung
Assembling instructions
Instructions de montage
Instrucciones de montaje
Montagevoorschrift
Istruzioni di montaggio
Monteringsanvisningar
Instrukcja monta u

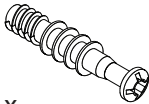
- DE** | Sehr geehrter Kunde,
Vielen Dank für den Kauf dieses DURABLE-Produktes. Sollte bei diesem Produkt etwas defekt sein oder ein Teil fehlen, wenden Sie sich bitte an Ihren Lieferanten oder den – DURABLE-Service. Nennen Sie die Teilenummer und Anzahl sowie Artikelnummer und Ihre vollständige Adresse oder faxen Sie uns das nachstehende Formular ausgefüllt. Wir werden Ihre Reklamation unverzüglich bearbeiten.
- GB** | Dear customer,
Thank you for purchasing one of our DURABLE products. Should you find that any of the contents are damaged and/or a part is missing then please contact your local reseller or dealer. Alternatively, you can contact the DURABLE Customer Services Department by faxing back the completed form below clearly stating which parts are required. Please add also the quantity of each piece required. Your request will be processed in the shortest delays.
- FR** | Cher client,
Merci d'avoir choisi les produits DURABLE. Si cependant, une pièce a été endommagée et/ou est manquante, merci de contacter votre revendeur ou le service client DURABLE en faxant ce document. Il vous suffit de compléter les informations suivantes en notant le code article du meuble, le nombre de pièces à changer dans la ou les cases concernées et en indiquant vos coordonnées. Votre requête sera prise en compte immédiatement.
- ES** | Estimado cliente,
Gracias por comprar productos DURABLE. Si en algún caso su contenido ha sido dañado y/o alguna parte o componente no aparece en el interior del embalaje por favor contacte con su proveedor o bien envíe un fax al Servicio de Atención al Cliente de DURABLE, solicitando la referencia del producto que necesita que le suministremos y las unidades requeridas (señalelas en número en el recuadro en blanco). Procesaremos su petición inmediatamente.
- NL** | Geachte klant,
Bedankt voor de aankoop van dit DURABLE product. Indien er onverhoopt een onderdeel zou ontbreken of beschadigd zijn, dan kunt u uw lokale verdeler contacteren of u kunt dit formulier faxen naar de DURABLE klantendienst. Vermeld duidelijk het onderdeelnummer en het aantal stukken dat moet vervangen worden. Uw aanvraag zal zo spoedig mogelijk worden verwerkt.
- IT** | Egregio Cliente,
La ringraziamo per l'acquisto di un prodotto DURABLE. Se tuttavia, il suo contenuto dovesse risultare danneggiato e/o mancante di qualche parte, La preghiamo di contattare il Suo fornitore oppure il Servizio Assistenza DURABLE e inviare per fax questo modulo completato, indicando il numero d'articolo e il numero e la quantità del pezzo che deve essere fornito. Procederemo immediatamente la Sua richiesta.
- SE** | Bäste kund,
Tack för att du har köpt en DURABLE-produkt. Om du upptäcker att något av innehållet är skadas och/eller fattas, vänligen kontakta din ordinarie kontorsvaruhandlare eller en lokal återförsäljare. Du kan även kontakta DURABLES kundtjänst genom att faxa tillbaka det ifyllda formuläret nedan och tydligt ange vilka delar som behövs. Ange även antalet av varje del. Din begäran kommer att behandlas snarast möjligt.
- PL** | Drogi Kliencie,
Dzi kujemy za wybór jednego z produktów DURABLE. W przypadku, gdy jeden z elementów jest uszkodzony i/lub brakuje jednej z części prosimy o kontakt z lokalnym sprzedawcą. Alternatywnie mo liwy jest bezpo redni kontakt z Biurem Obslugi Klienta DURABLE poprzez przefaksowanie wypelnionego formularza okre laj cego jaka cz est potrzebna. Prosz umie ci obok cz ci informacj na temat potrzebnej ilo ci. Pa stwa wniosek zostanie rozpatrzony w mo liwie najkrótszym czasie.
- RU** |

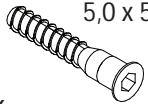
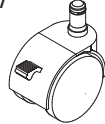
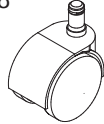
DURABLE.

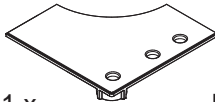
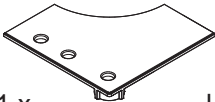
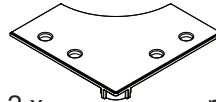
DURABLE,

15747 10 x 15/19 	21387 10 x 6,3 x 20 	21343 Grey 21347 Brown 6 x 	31163 2 x 5,0 x 50 	21417 2 x 	21388 2 x 
15726 12 x j 	15730 1 x k 	15729 1 x l 	15727 2 x m 	21351 Grey 21345 Brown 2 x n 	21376 Inbus 1 x o 

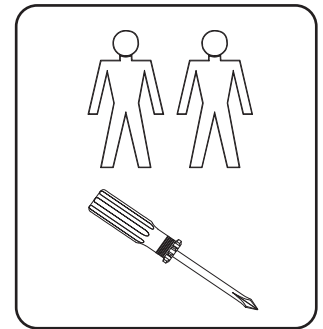
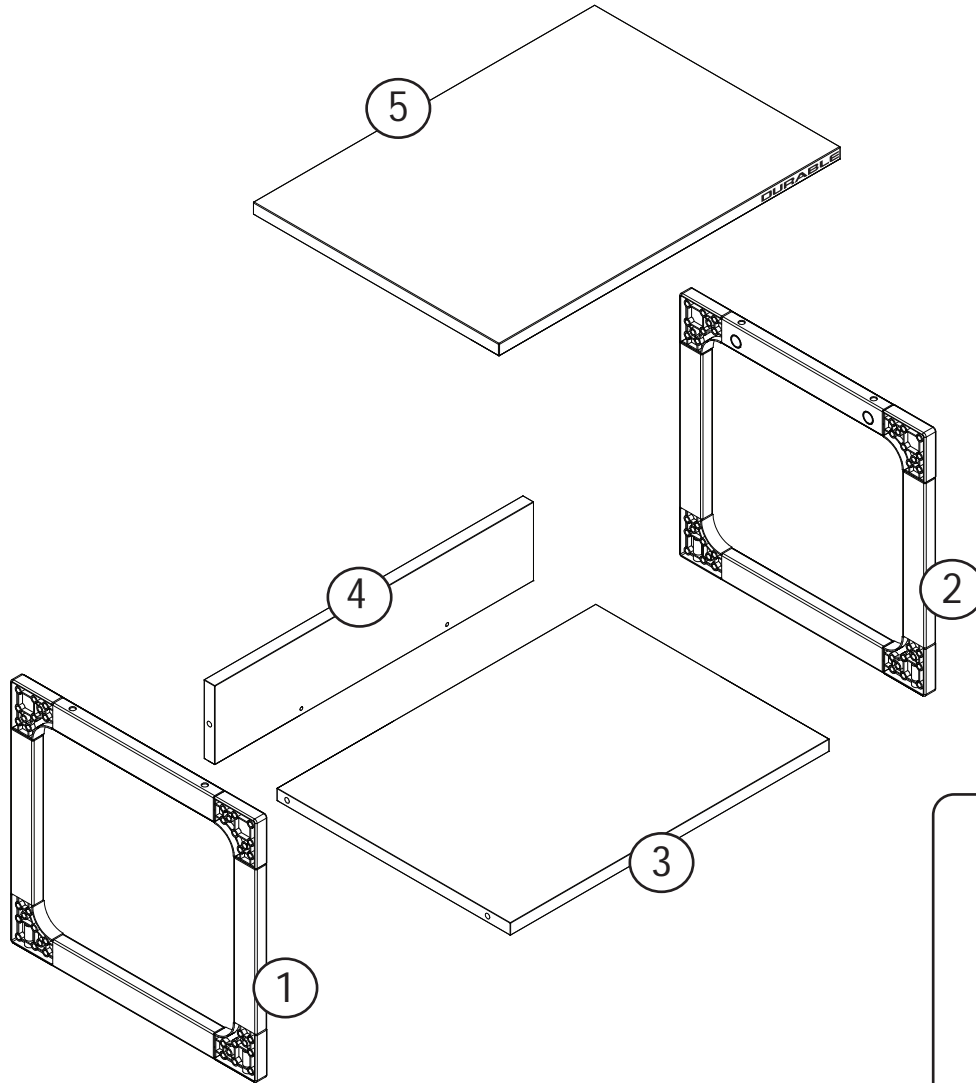

3710

An | Ship to | à envoyer à | A | Aan | Skicka till | Wysyłka do | :
 Firma | Company | Société | Firma | Ditta | Företag | Firma | :

z.Hd. | Att. | à l'attention de | t.a.v. | attenzione | Att. | Osoba odpowiedzialna | :

Straße | Street | Rue | Calle | Straat | Strada | Gata | Ulica | :

Ort | City | Ville | Residencia | Plaats | Residenza | Ort | Miasto | :

Land | Country | Pays | Pais | Land | Paese | Land | Kraj | :

PLZ | Zip | Code postal | Codigo Postal | Postcode | C.A.P. | Post nr | Kod pocztowy | :

Tel. | Phone | téléphone | No | Tel | Telefon | : Fax:

E-mail:

1

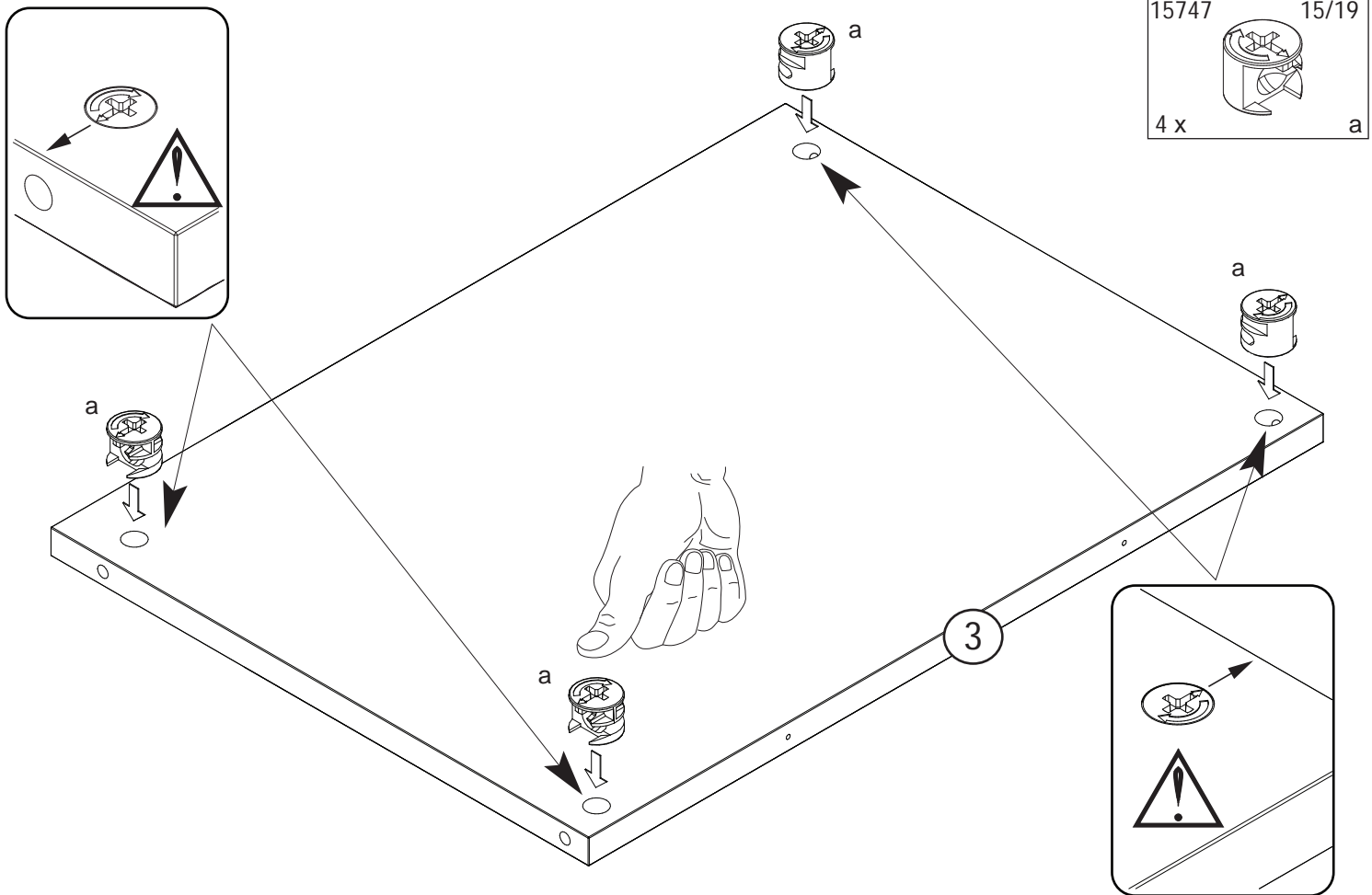

2

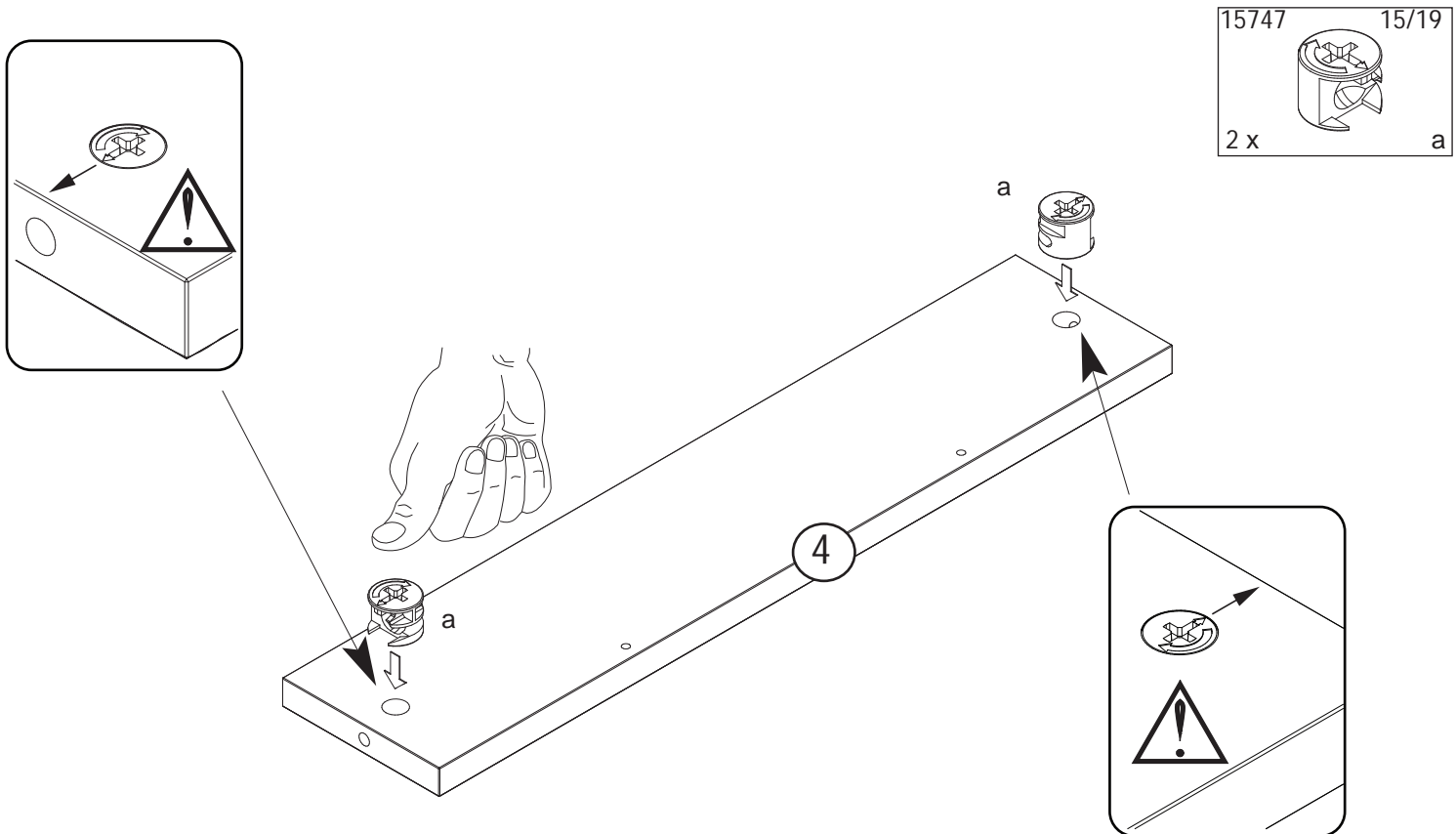

3

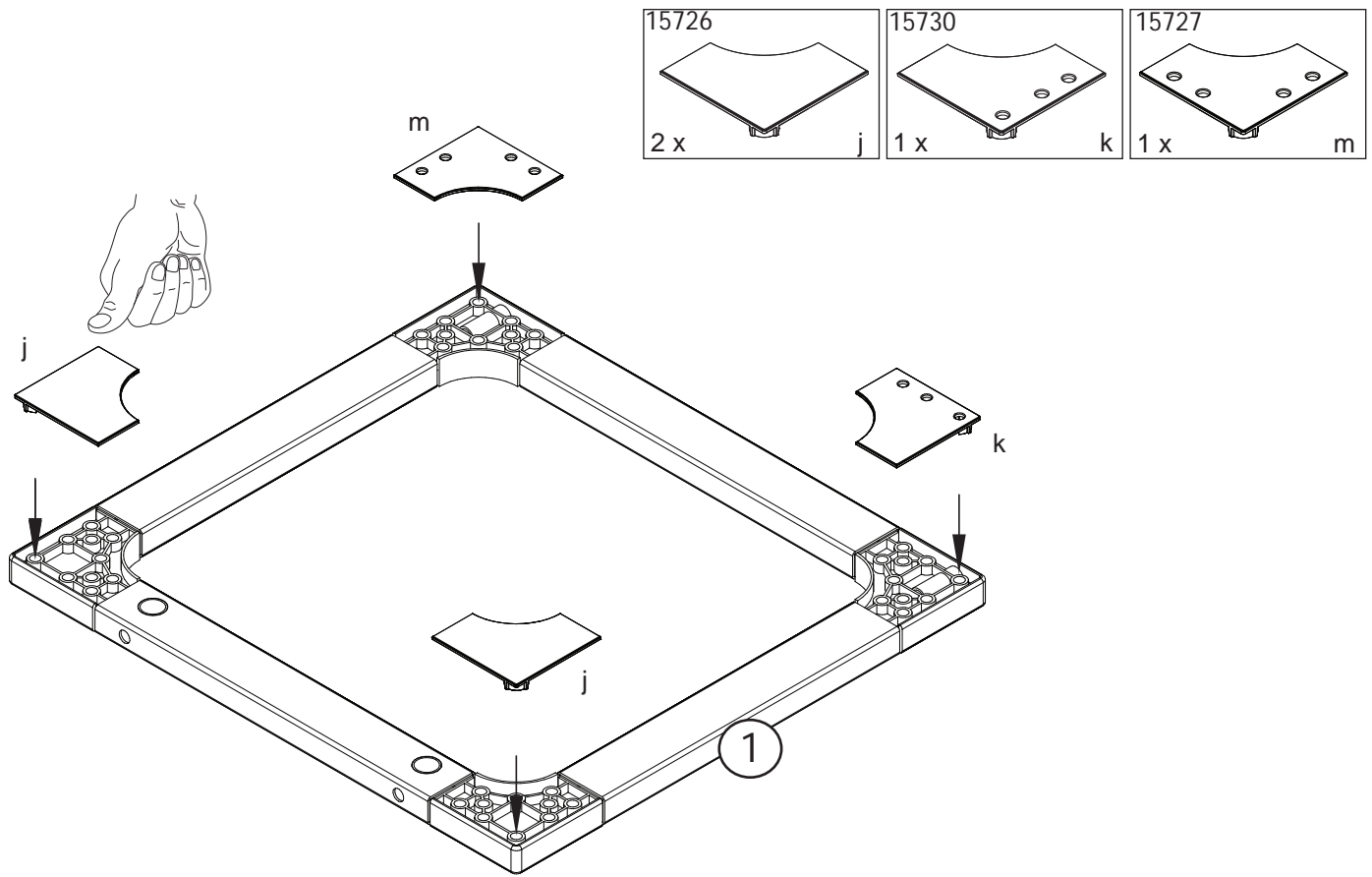

4

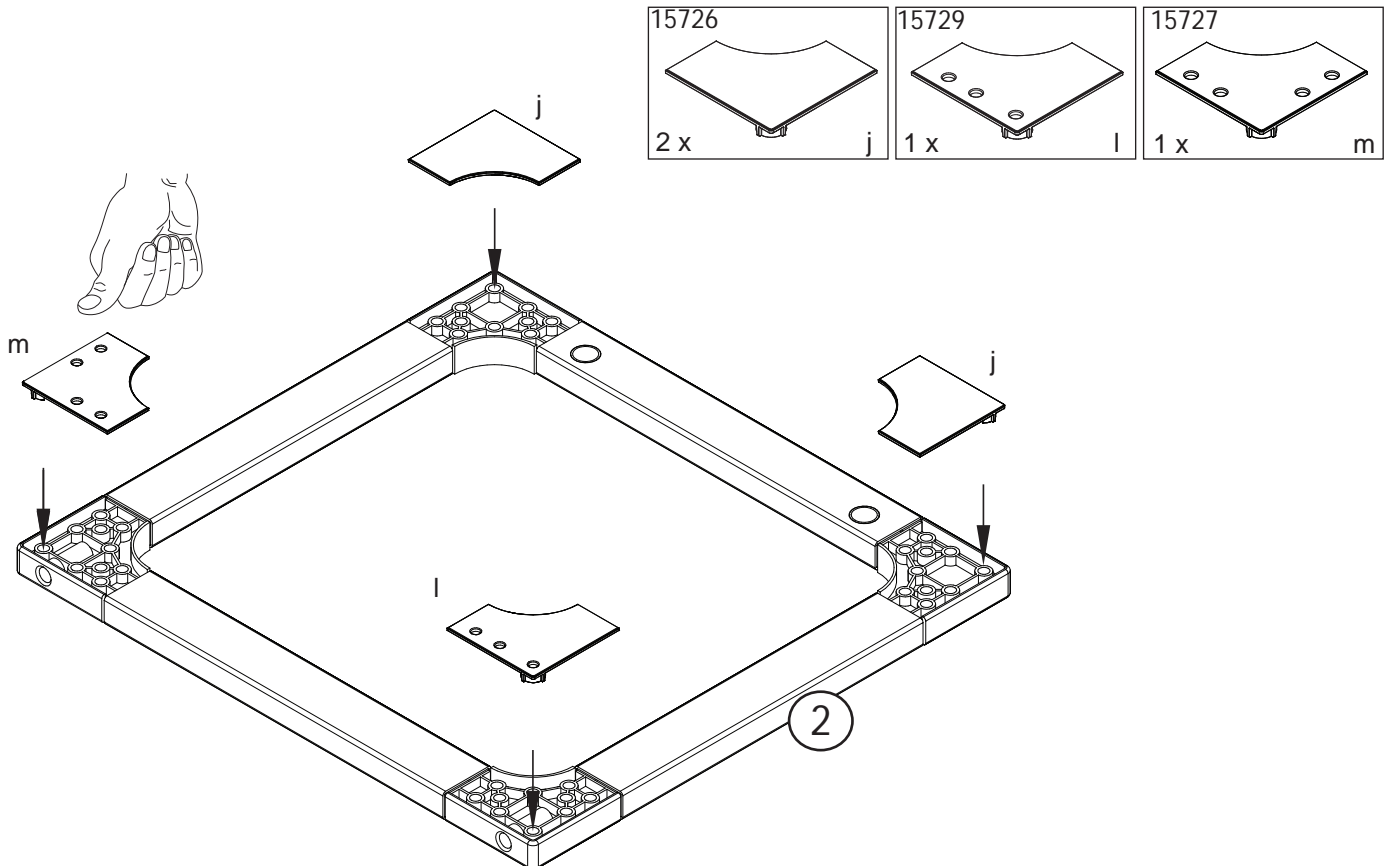

5

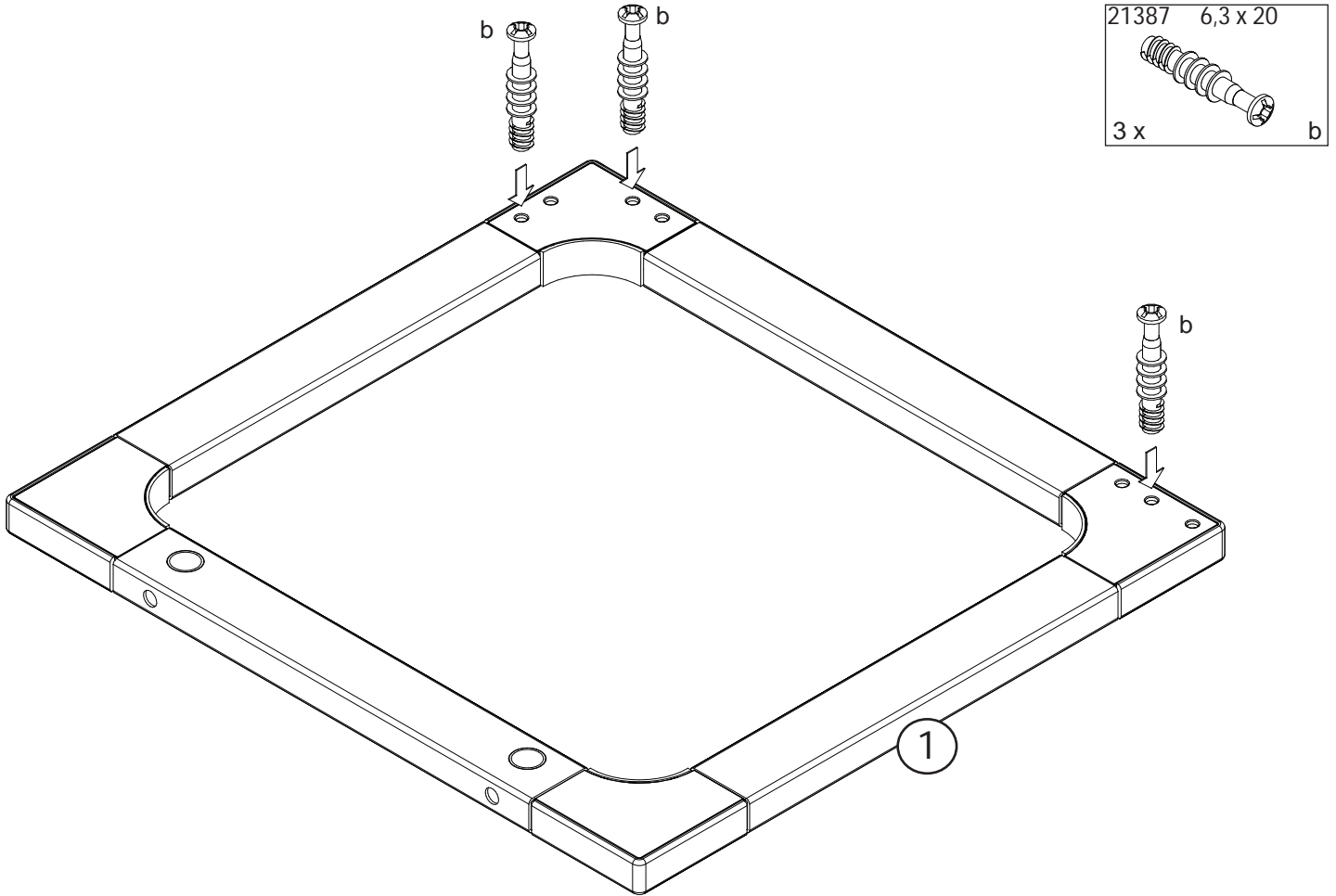

6

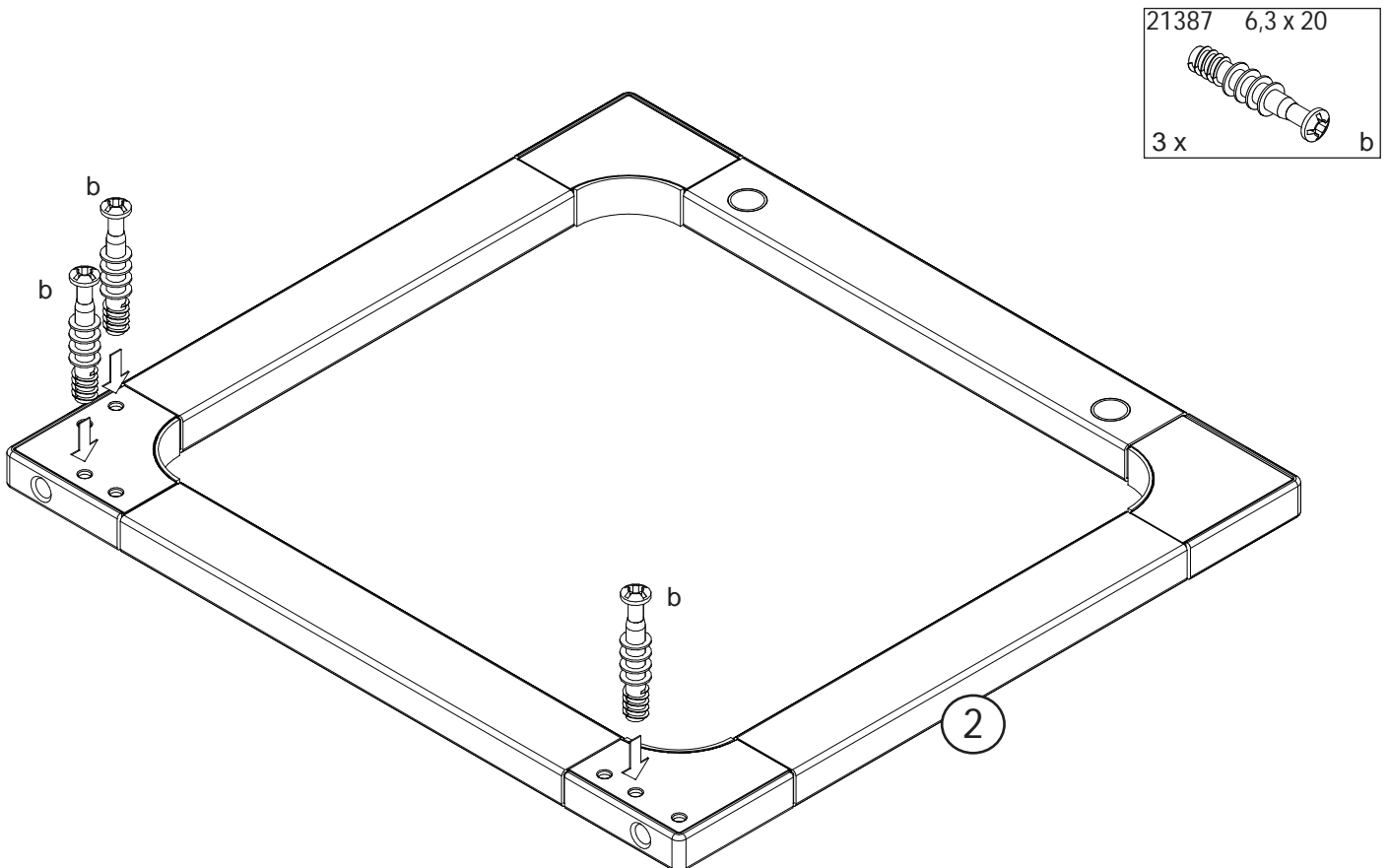

7

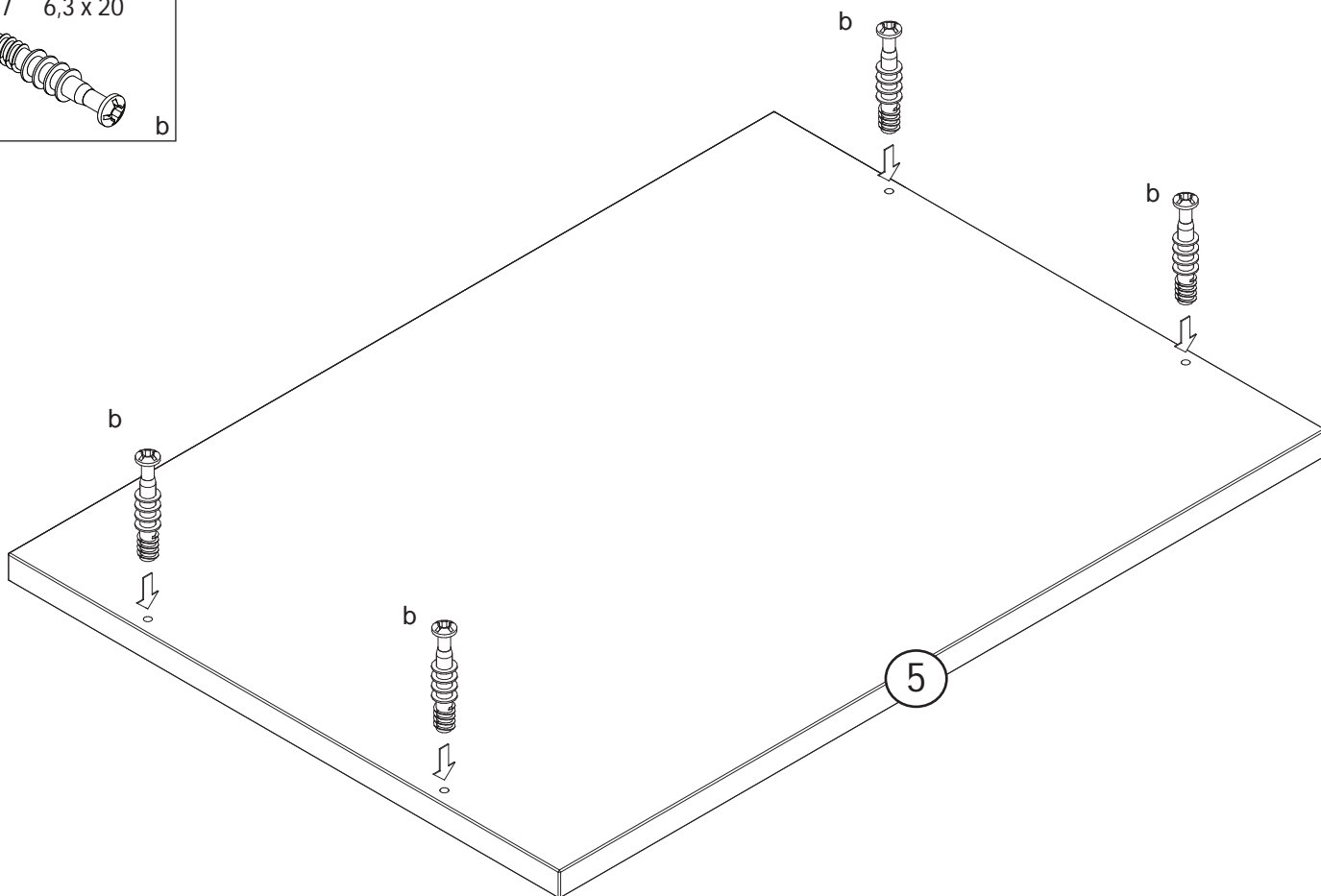
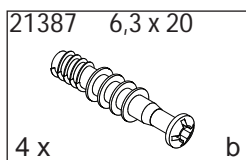

8

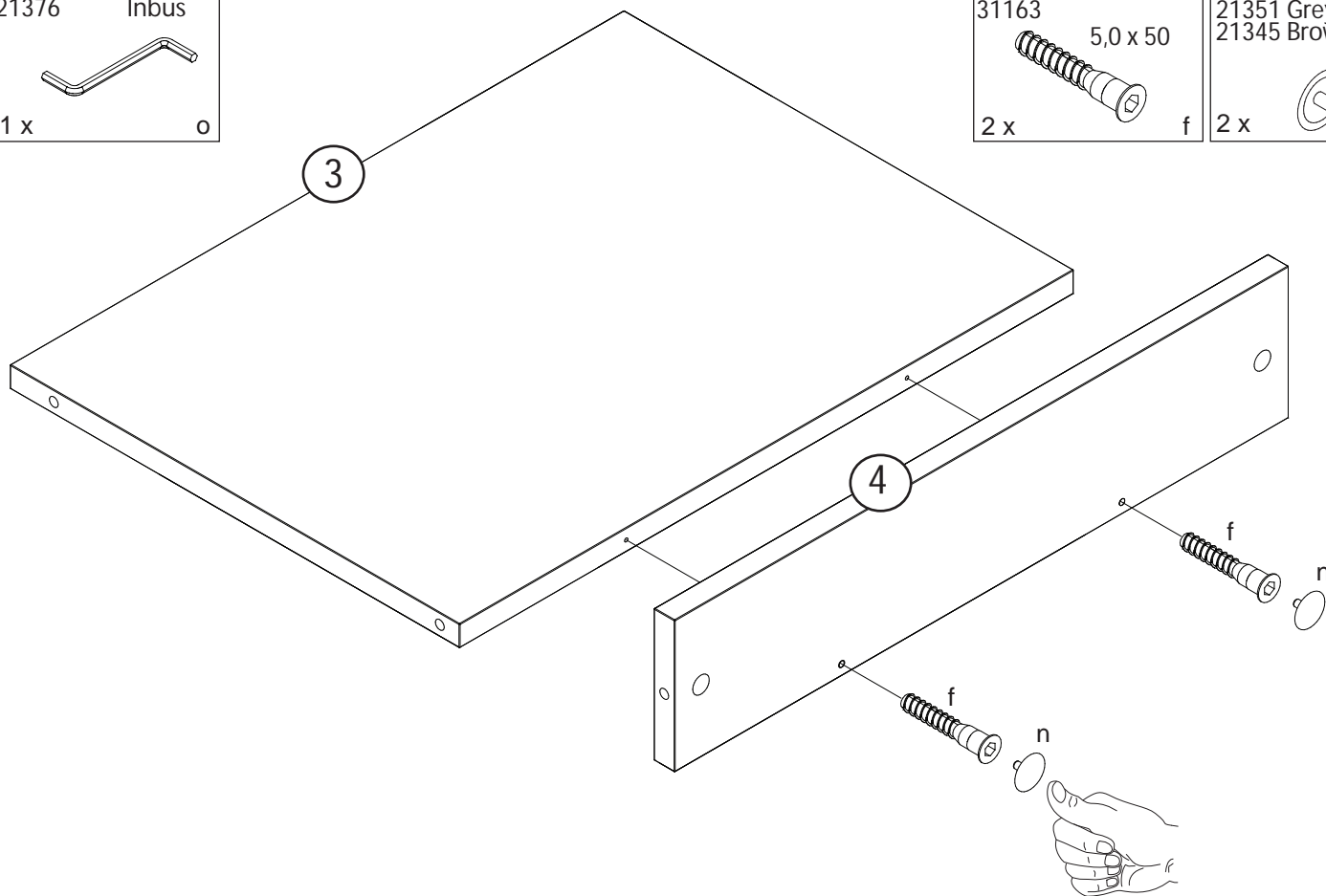
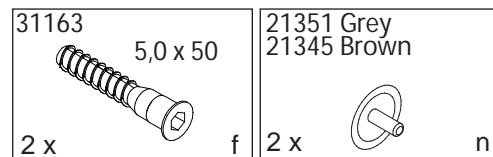
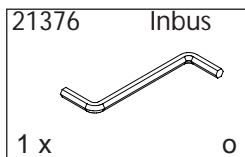

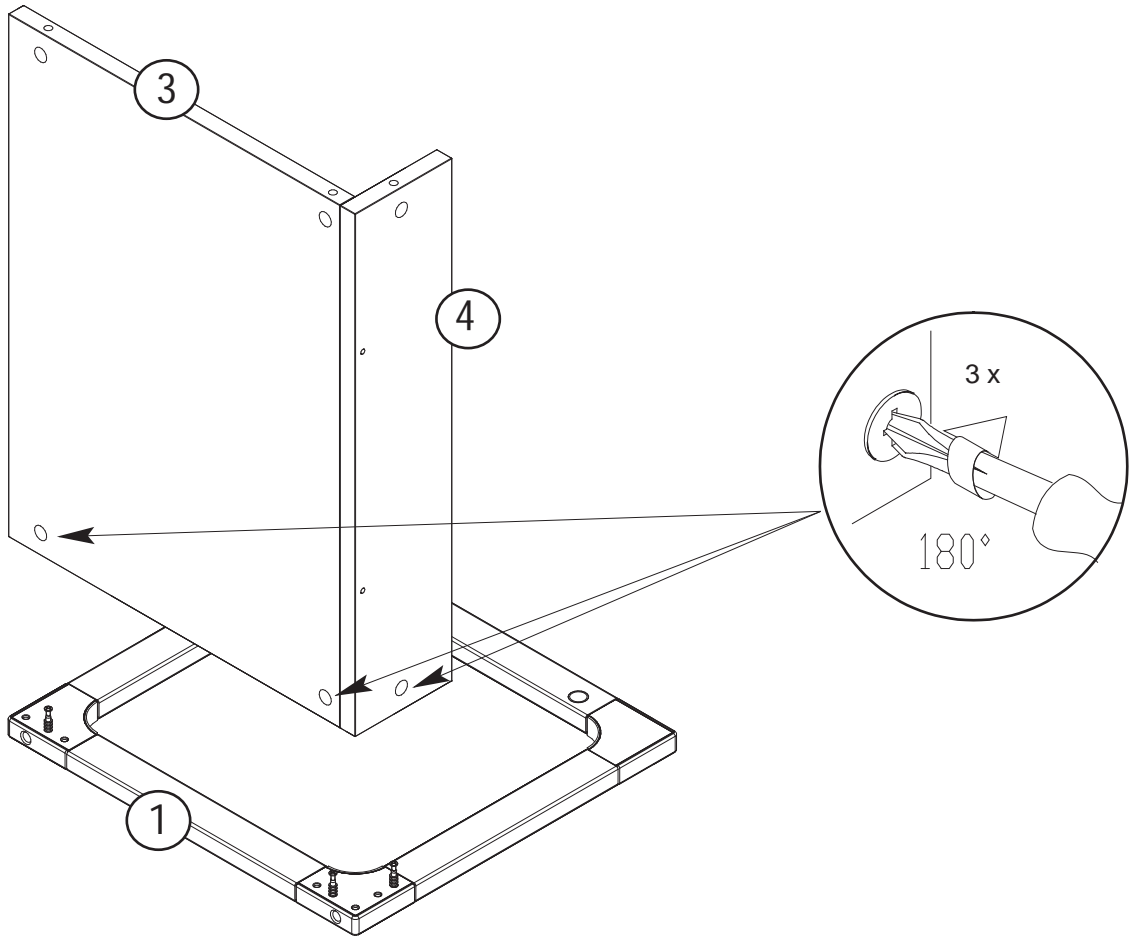

21343 Grey
21347 Brown



2 x

m

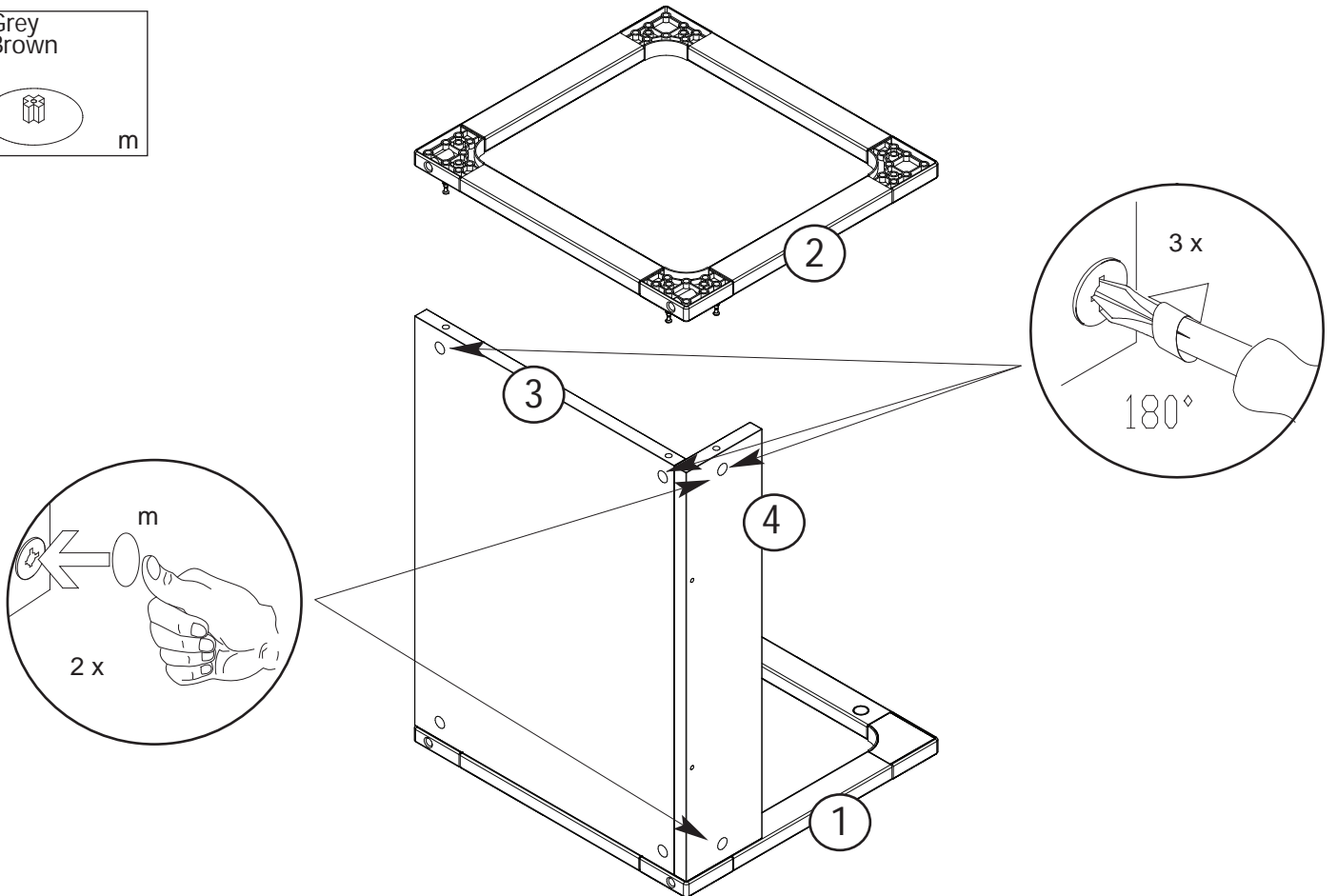

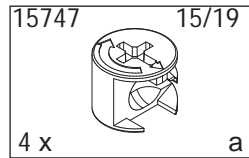
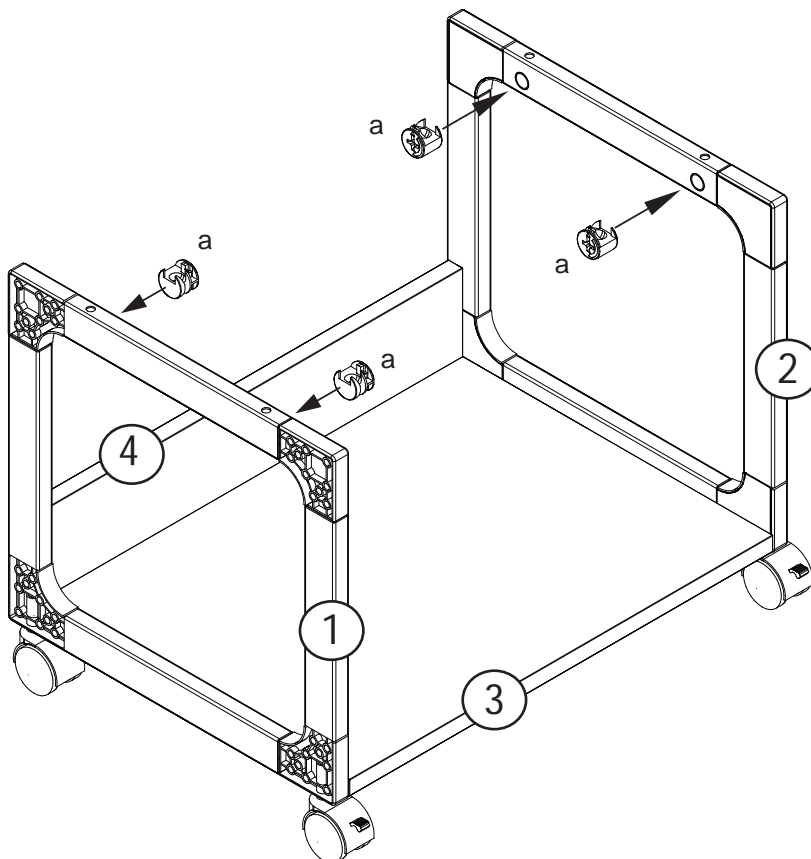
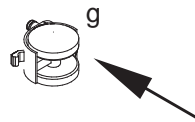
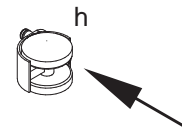
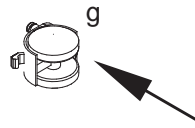
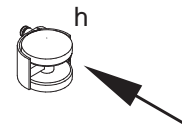
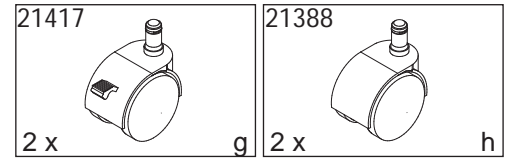
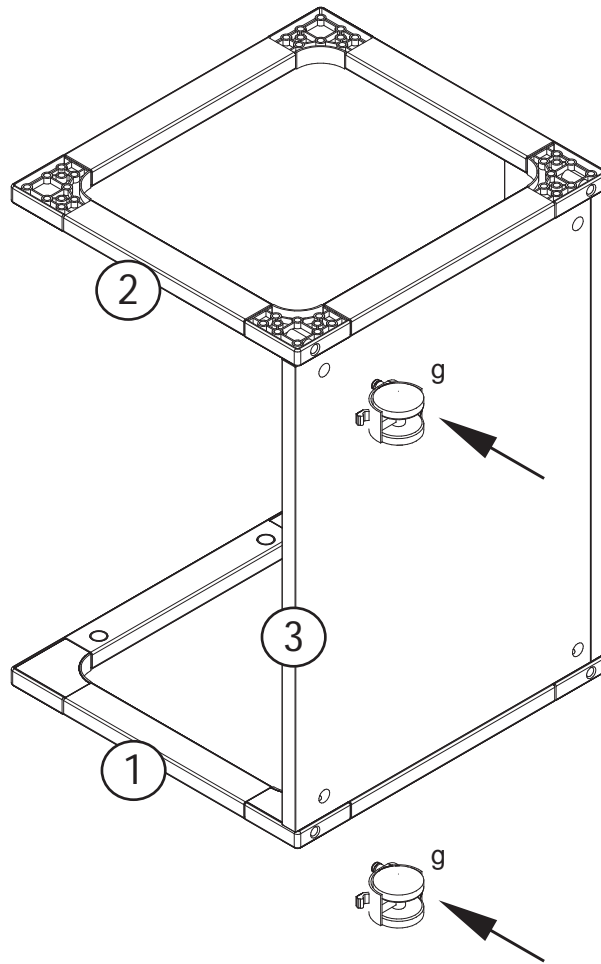

13

21343 Grey
21347 Brown



4 x m

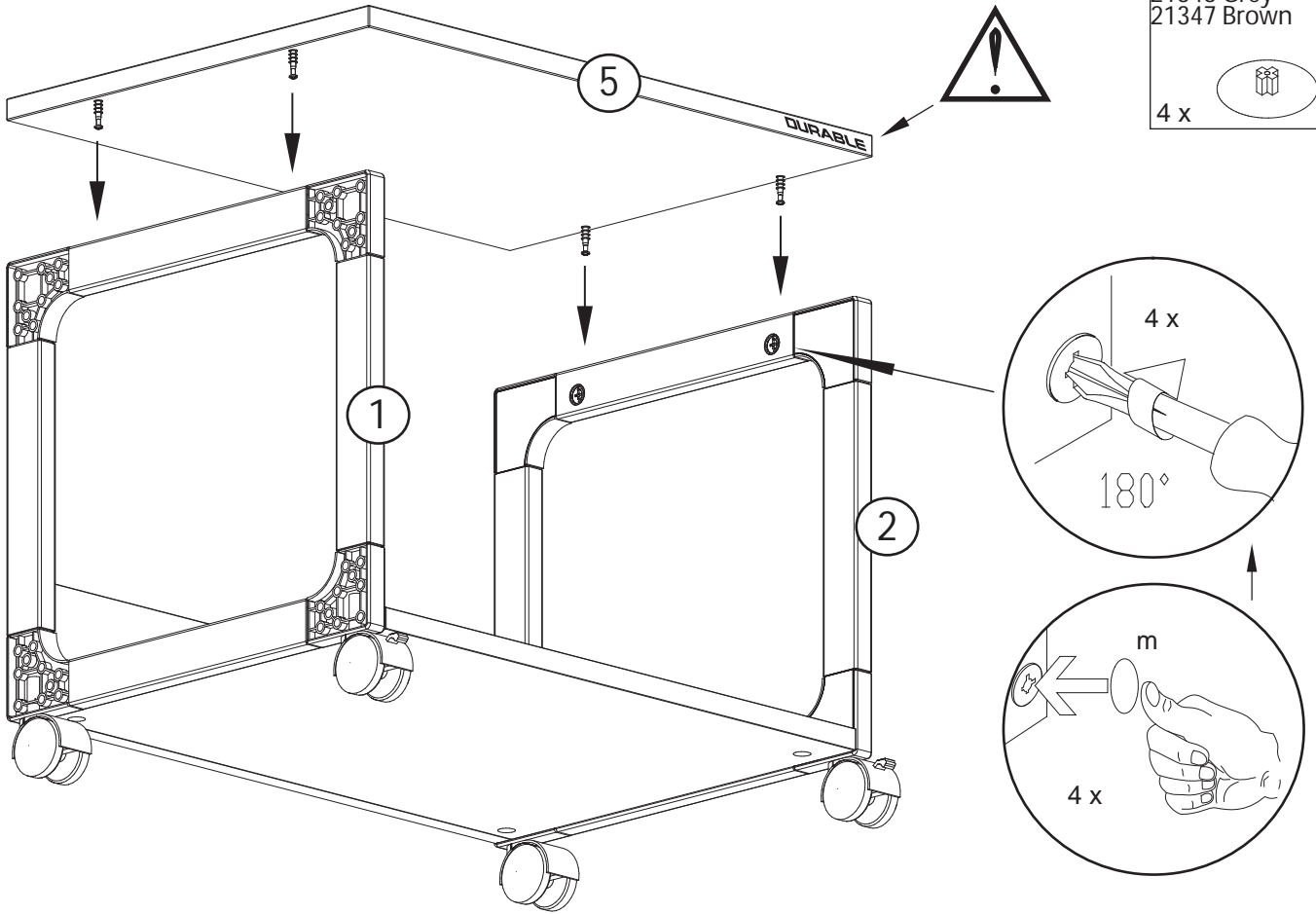

14

