

# SHOWCAST 100

All-in-One 4K Production Studio



## Features



- 4K 60/p live video production ideal for IMAG applications
- Integrated PTZ camera control with presets, focus, white balance, & iris
- H.264 dual streaming & recording encoder\*
- Audio mixer for mixing embedded and external audio sources
- Tactile buttons combined with a 14" intuitive touch screen interface with transition controller

\*Streaming and recording max resolutions at 1080p/60.

## Overview

The SHOWCAST 100 is an all in one switcher featuring Video Switching, Streaming, Recording, Camera Control and Audio Mixing in one box. It is a UHD 4K 4-input switcher with an integrated 14-inch touch panel. The built-in network streaming encoder allows you to stream videos to all major streaming platforms live. Moreover, the video stream can be recorded to the SD card for backup purpose. The SHOWCAST 100 offers remote control of multiple cameras settings such as pan, tilt, zoom, iris, focus, gain and white balance. It connects up to 3 Datavideo cameras over a long distance via Ethernet cables.

The switcher is equipped with luma key for graphic overlays, split screen for podcast interviews, and PiP for PowerPoint presentations. It is also equipped with a built-in audio mixer allowing users to directly connect microphones and other audio sources.

## Recommended Accessories

### Datavideo:

- PTC-280 12x 4K PTZ Camera
- PTC-300 20x 4k PTZ Camera
- HBT-30 3-Channel HDBaseT Receiver with HDMI Outputs
- HDR-80 ProRes 4K Video Recorder- Desktop

# SHOWCAST 100

All-in-One 4K Production Studio

## SHOWCAST 100 Front Panel

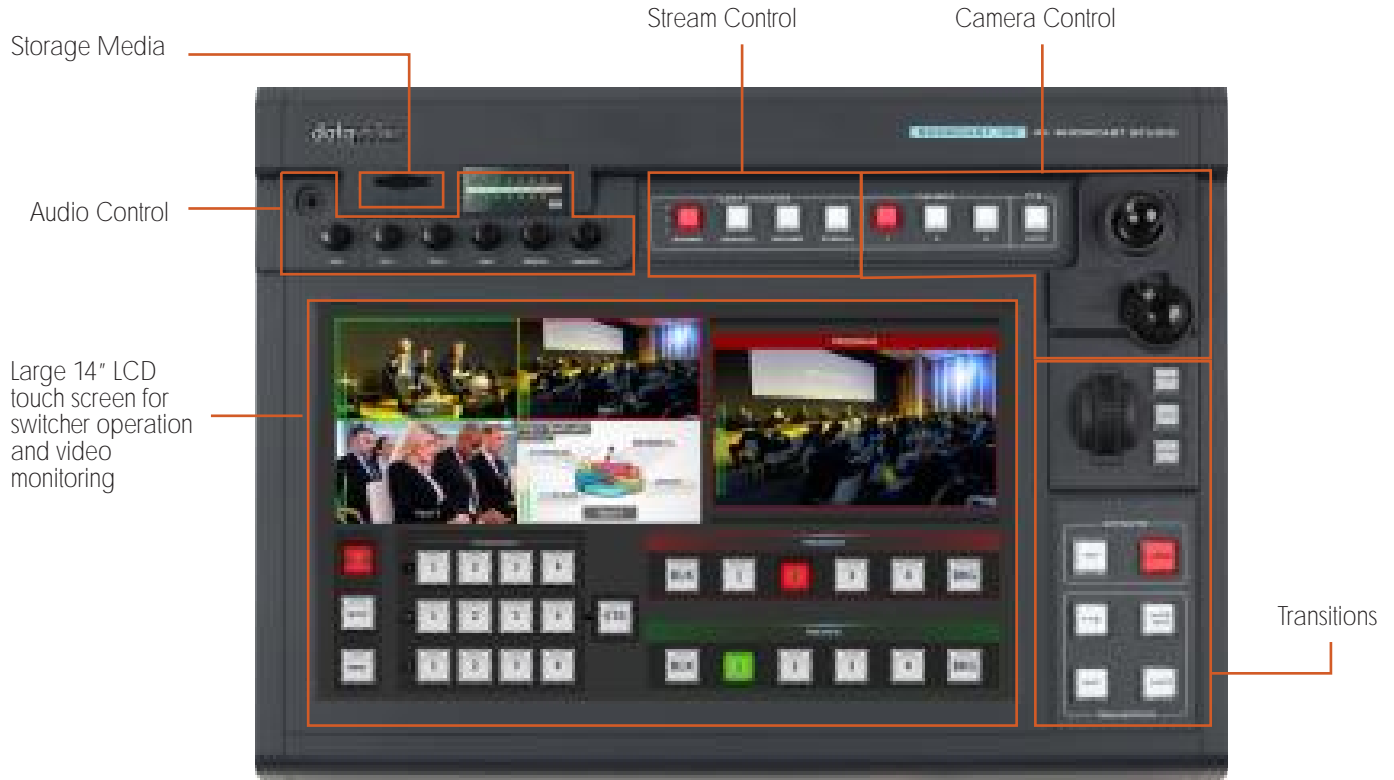

## SHOWCAST 100 Rear Panel

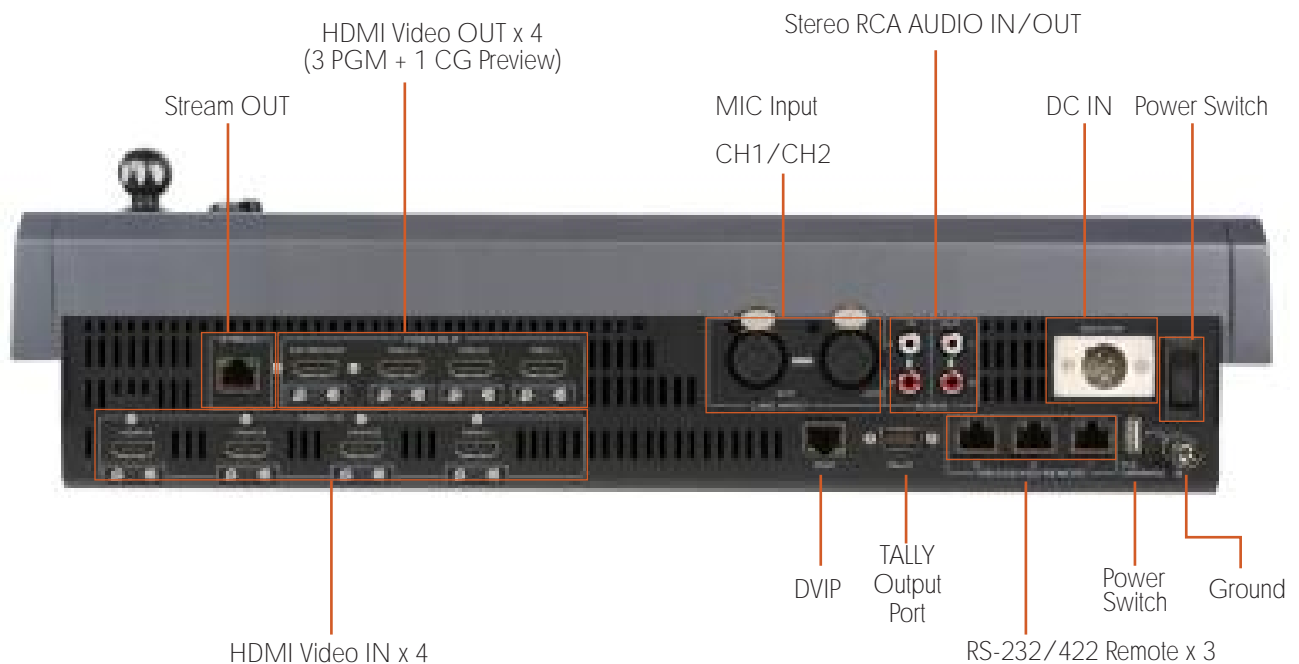

# SHOWCAST 100

All-in-One 4K Production Studio

## Workflow

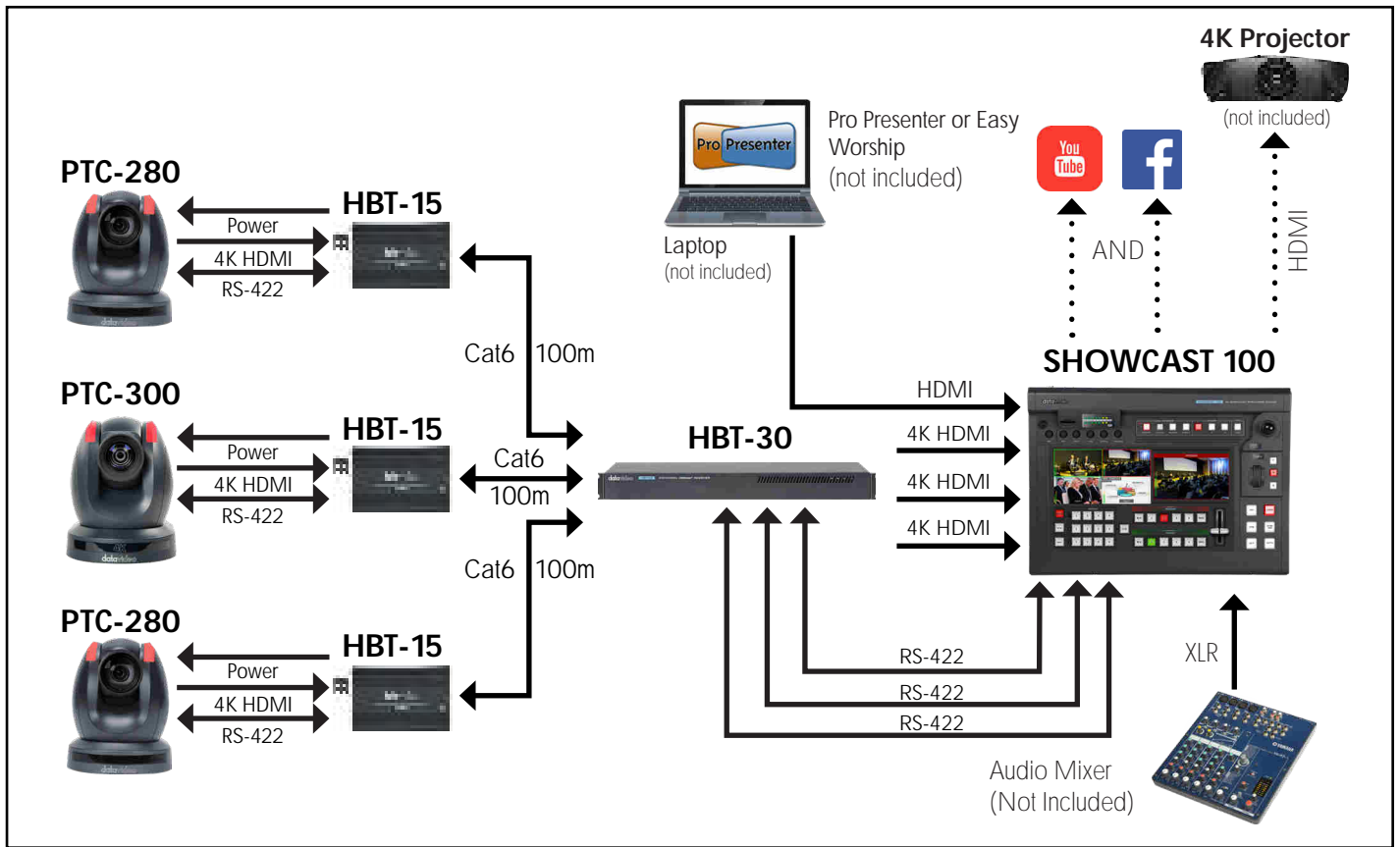

## Dimensions

All measurements in millimeters (mm)



## Specifications

Model Name	<b>SHOWCAST 100</b>
<b>Product Name</b>	All-in-one 4K Production Studio
<b>Video format</b>	Input: 3840x2160p: 60/59.94/50/30/29.97/25/24/23.98 1080p: 60/59.94/50/30/29.97/25/24/23.98 1080i: 60/59.94/50, 720p: 60/59.94/50 VGA, XGA (1024 x 768), SXGA (1280 x 1024), UXGA (1600 x 1200), WUXGA (1920 x 1200)  Output: 3840x2160p: 60/59.94/50/30/29.97/25/24/23.98 1080p: 60/59.94/50/30/29.97/25/24/23.98
<b>Video Processing</b>	4K60 YUV4:4:4 8bit, YUV 4:2:2 8/10bit, YUV 4:2:0 8bit, RGB 4:4:4 8bit 4K30 YUV4:4:4 8/10/12bit, YUV 4:2:2 8/10/12bit, YUV 4:2:0 8bit, RGB 4:4:4 8/10/12bit HD YUV4:4:4 8/10/12bit, YUV 4:2:2 8/10/12bit, RGB 4:4:4 8/10/12bit
<b>Input Routable / Crosspoint</b>	N/A
<b>Video Input</b>	4 x HDMI 2.0
<b>Mix HD &amp; SD Source</b>	----
<b>Video Output</b>	3 x HDMI 2.0 for PGM 1 x HDMI for CG Preview
<b>Down-converted Output</b>	Yes
<b>Built-in Multi-view Monitoring Out</b>	On 14" Touch Panel
<b>Analogue Audio Input</b>	2 x 3 Pin XLR / 1/4" (6.3mm) Combo Socket 1 x Stereo RCA set (L/R)
<b>Analogue Audio Output</b>	1 x Stereo RCA set (L/R) 1 x Stereo headphone (Mini Jack with volume control)
<b>Digital Embedded Audio Support</b>	Input 2 channels, Output 2 channels
<b>Audio Delay Calibration</b>	Up to 200ms
<b>A+V Switching</b>	Yes
<b>Chromakey</b>	----
<b>Title Creator</b>	Web GUI
<b>USK</b>	Lumakey
<b>DSK</b>	----

## Specifications

Model Name	SHOWCAST 100
Product Name	All-in-one 4K Production Studio
Logo Insertion	----
Still Store	----
Effects	Seamless Cut, WIPE, Mix
Tally Output	D-Sub -15 Male connector
PC Remote Control	Web browser UI for configuration and control Socket commands
Camera Control	DVIP/ RS-422/ RS-232
Built-in Audio Mixer	Yes
Storage	1 x SD Card Slot Supports SD, SDHC and SDXC card (UHS-I) (Class 10 above)
Recording File System	FAT, NTFS, exFAT
Recording File Format	MP4
Video Encode	H.264 / AVC, Main/ High Profile Record Only: Up to 16Mbps (1080p 50/60) Stream Only: Up to 10Mbps (1080p 50/60) Rec and Stream: Up to 10Mbps (1080p 25/30) Rec and Stream: Up to 36Mbps (1080p50/60), Dual Stream
Audio Encode	AAC-LC Configurable bit rate range from 32Kbps to 384Kbps Sample rate: 48KHz, 16bit
Streaming Protocol	TS over TCP/UDP (unicast & multicast) RTSP over HTTP/TCP/UDP (RTSP Elementary Streaming) RTMP (Publish)
Firmware Update	Ethernet, USB
Special Features	14.0" Touchscreen Display
Chassis	Unibody
Dimension (LxWxH)	437.6 x 330.5 x 96.5mm
Weight	5.4 Kg
Power	DC 12V 82W
Operating Temp. Range	0~40 °C

# SHOWCAST 100

All-in-One 4K Production Studio

## What's in the Box

- 1 x Showcast 100 product
- 1 x AD Switch DC 12V with AC Cord

## Applications

- Live Event Meetings
- Tradeshows
- Townhall Meetings
- Government Events
- Worship Services
- Musical Performances
- Lectures

## Available Documents to Download

1. Datasheet
2. Instruction Manual
3. Cutsheet
4. Firmware Update



For more info, visit [www.datavideo.com/product/showcast 100](http://www.datavideo.com/product/showcast-100)



@DatavideoUSA  
@DatavideoEMEA  
@DatavideoTaiwan

@DatavideoAsia  
@DatavideoIndia2016  
@Datavideojapan



@Datavideo  
@Datavideo\_EMEA  
@Datavideo\_Taiwan



@DatavideoUSA  
@DVTWDVCN



@DatavideoUSA  
@DatavideoEurope

### Disclaimers of Product and Services

This sheet is intended as a guide only. We reserve the right to change specifications and availability without prior notice. While we strive for complete accuracy, be aware that it may contain errors and omissions. Prior to purchase, please check with your local Datavideo office or authorised distributor.