

RevNo	Revision note	Date	Signature	Checked
-------	---------------	------	-----------	---------

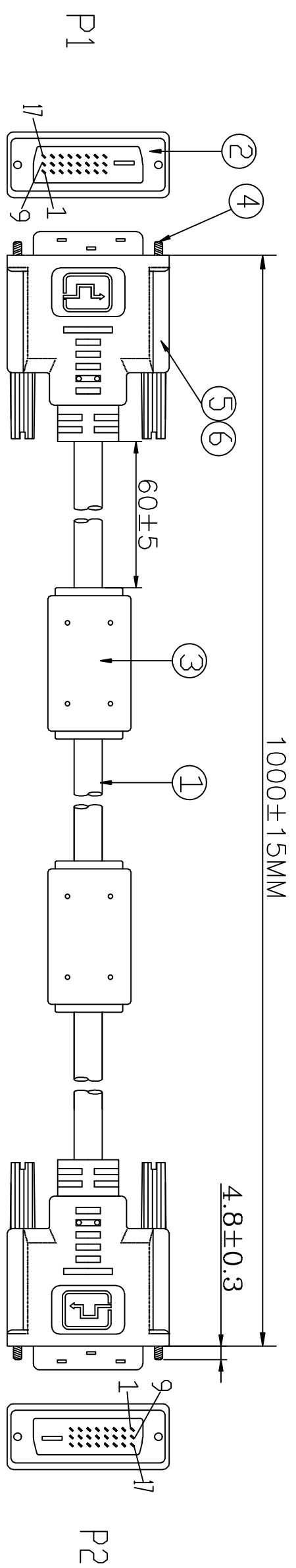

PIN OUT

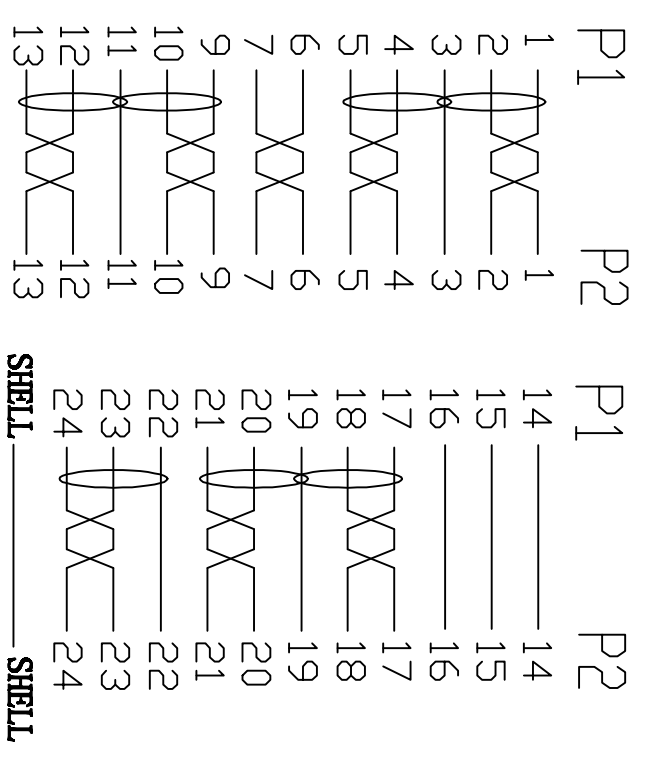

REQUIREMENTS:

- 1:100% short,open and miss wire test.
- 2:Insulation resistance:DC300V 10MΩ(Min)
Conduction resistance 5Ω(Max)

⑥	OUTER MOLDED	BLACK 45P PVC	0.038	KG
⑤	INTER MOLDED	LDPE	0.021	KG
④	SCREW	#4-40UNC 2.3*45.5MM,BLACK PVC	4	PCS
③	FERRITE CORE	F5B:RH12*20*8.0	2	PCS
②	CONNECTOR	DVI 24+1/M BLACK INSULATOR,NICKEL PLATED SHELL, GOLD PLATED PIN	2	PCS
①	CABLE	(1P*30#+FME+D+AL+MYLAR)*7C+1P*30#+3C*30#+ADB JACKET: BLACK PVC OD:7.3±0.15	1	M
NO.	MATERIAL	DESCRIPTIONG	QTY.	UNIT

Ltemref	Quantity	Title/Name,designation,material,dimension etc	Article No./Reference
Designed by ACHY	Checked by HELEN	Approved by - date MARCH 6.2012	Date MARCH 6.2012
		File name DVI24+1 M/M L-™	Scale FREE
		32 27 99	

1MDVI DUAL		Edition	Sheet
		1	1/1