

# VESTEL

---

---

## 75" (189cm) INTERACTIVE FLAT PANEL DISPLAY

---

---

### USER MANUAL

DA75A-6K

ENGLISH



## Table of Contents

Important Safety Information.....	2
General View.....	6
Control Buttons on the Display .....	7
Turning the Display On/Off .....	7
Embedded Infrared Overlay Touch Screen.....	9
Remote Control.....	10
General Use .....	11
Initial Setup.....	11
Home Screen .....	12
General Tools Bar .....	12
Tools Board .....	13
Settings Board .....	14
Users Board.....	14
Quick Palette .....	15
Login .....	15
Account Management System (AMS).....	16
Favourite Applications .....	16
All Applications .....	17
Recent Applications.....	17
Display Settings Menu Content .....	17
Operating System Settings Menu Content.....	22
Installing Third Party Applications .....	23
Connectivity .....	24
Media Player Applications .....	25
CEC and CEC RC Passthrough.....	26
USB TYPE-C .....	27
HDMI Out.....	27
Real Time Clock (RTC).....	27
Controlling With An External PC .....	27
RS232/LAN Command Table .....	29
Maximum Pixel Rates .....	48
Input Matrix .....	48
Supported Media Formats from USB .....	48
System Features .....	52
Accessories Included.....	52
Licence Notification.....	53
Vesa Wall Mount Measurements .....	54
Installation On An Indented Wall.....	55

## Important Safety Information



**CAUTION:** TO REDUCE THE RISK OF ELECTRIC SHOCK DO NOT REMOVE COVER (OR BACK). NO USER-SERVICEABLE PARTS INSIDE. REFER SERVICING TO QUALIFIED SERVICE PERSONNEL.

**OPS USAGE WARNING:** Do not plug the OPS unit while the Display is turned on. Turn on the OPS unit using the remote control or the buttons on the Display, do not turn it on using the buttons on the device itself.

### Please read these instructions fully and carefully before use and keep for future reference

**WARNING:** This device is not intended for use by persons (including children) without physical, sensory or mental capabilities, or lack of experience and/or knowledge unless they have been given supervision or instruction concerning use of the device by a person responsible for their safety.

- This product is for indoor use only.
- Use this product at an altitude of less than 5000 metres above the sea level and in dry locations and in regions with moderate or tropical climates.
- Please keep this manual for further use.
- Unplug your product before starting to clean. Do not clean the product when it is on. Do not use liquid or aerosol cleaners. Use a damp cloth for cleaning. If that does not help, please use LCD display cleaners. Do not apply the cleaner directly on the product.
- To prevent breakdown, do not use non-advised accessories.
- Please do not place your product near wash basins, sinks, water pans, pools, etc.
- Do not expose the product to dripping or splashing of liquids and do not place objects filled with liquids, such as vases, cups, etc. on or over the product (e.g. on shelves above the Display).
- Please leave at least 5 cm of free space between the product and walls or other furnitures for ventilation purposes.
- That product can only be started by the defined power source on its rating plate. For further information, please contact with your dealer.
- As a safety precaution, a three-wired grounding plug is given with the product. As a safety precaution, please do not make any change on the grounding plug. Always use earthed socket outlet for product.
- Please provide the plug and socket to supply the needed power for appliance.

- Please place the product in a position that electric cables cannot be affected by the operations on the product.
- Follow all warnings and instructions marked on the product.
- Follow the on screen instructions for operating the related features.
- To prevent the risk of fire or electric shock, please do not overuse the plugs and extension cords. Please do not open the lid of the monitor to service yourself. If the required service needs are not met by an authorized service, dangerous voltage and other risks may occur.
- If you will not use the product for a long period of time, unplug the power cord from the mains.
- Put the product on a well-ventilated place and prevent from bright light, overheat and damp.
- The product should be kept in 0 °C - 40 °C. Otherwise, the appliance may be damaged permanently.
- Plug the appliance to a grounded outlet. Always use the grounded power cord supplied with your product. Manufacturer is not responsible for any damage caused unearthed usage.
- The socket-outlet shall be installed near the equipment and shall be easily accessible.
- Do not stay in contact with the parts of the product that become hot for long periods of time. Doing so may result in low-temperature burns.
- The LCD panel used in this product is made of glass. Therefore, it can break when the product is dropped or applied with impact. Be careful not to be injured by broken glass pieces in case the LCD panel breaks.
- Usage of the monitor must not be accompanied by fatal risks or dangers that, could lead directly to death, personal injury, severe physical damage or other loss, including nuclear reaction control in nuclear facility, medical life support system, and missile launch control in a weapon system.
- Do not expose the product to direct sunlight or do not place open flames such as lit candles on the top of or near the product.
- Do not place any heat sources such as electric heaters, radiators, etc. near the product.
- In order to prevent a potential electrical shock, in extreme weather (storms, lightning) disconnect the product from the mains.
- Do not touch the controls other than those described in the operating instructions. Improper adjustment of controls not described in the instructions can cause damage, which often requires extensive adjustment work by a qualified technician.
- Do not shake the product. Ensure that it stays in a balanced stance on its position.
- Do not throw or drop any object on your product.

- Do not interfere on your products screen or any other surface with a sharp object.
- Do not keep your product in a humid environment.
- Do not keep your product in an extremely cold environment.
- Do not keep your product in an extremely hot environment.
- Do not place the product on the floor and inclined surfaces.
- To avoid danger of suffocation, keep plastic bags out of the reach of the babies, children and domestic animals.

### **Vent holes of the product**

The vent holes are designed to provide the product to work constantly and prevent it from overheating. Do not block these openings in anyway. For the same reason, please do not place your product on beds, sofas, carpets and similar surfaces.

Never insert an object into the product through vents or openings. High voltage flows in the product, and inserting any objects in the vents or openings of the product may cause electric shock, short circuit of the internal parts and/ or fire. For the same reason, do not spill water or liquid on the product.

### **Repair**

Unless a basic implementation on the product is specified by the producers' technical department on a document, do not repair your product by yourself. Otherwise, your guarantee may get suspended and you may risk your health or your product. In case of need, consult your authorized service.

- When the cable is worn off or harmed.
- If the product has been dropped or the cabinet has been damaged.
- If the performance of the product is changed or the appliance needs to be repaired.
- When a liquid was spilled on the product or when objects have fallen into the product.
- When the product has been exposed to rain or water.
- When the product does not operate properly as described in the operating instructions.

### **Replacement parts**

In case the product needs replacement parts, make sure that the service person uses replacement parts specified by the manufacturer, or those with the same characteristics and performance as the original parts. Use of unauthorized parts can result in fire, electric shock and/ or other danger.

### **Safety checks**

Upon completion of service or repair work, request the service technician to perform safety checks to ensure that the product is in proper operating condition.

### **Wall mounting**

When mounting the product on a wall, be sure to install the product according to the method recommended by the manufacturer.

- Read the instructions before mounting the product on the wall.
- The wall mount kit is optional. You can obtain from your local dealer, if not supplied with the product.
- Do not install the product on a ceiling or on an inclined wall.
- Use the specified wall mounting screws and other accessories.
- Tighten the wall mounting screws firmly to prevent the product from falling. Do not over-tighten the screws.

### **Power Cord**

- The power cord is used to disconnect the product from the mains and therefore it must remain readily operable. If the product is not disconnected electrically from the mains, the device will still draw power for all situations even if the product is in standby mode or switched off.
- Use only the power cord supplied with the monitor.
- Do not damage the power cord nor place heavy objects on it, stretch it, over bend it or step on it. Also, do not add extension cords. Damage to the cord may result in fire or electric shock.
- When unplugging the appliance, always pull directly on the plug. Do not pull from the cable when unplugging the appliance.
- Do not use the power cord with a power tap. Adding an extension cord may lead to fire as a result of overheating.
- Do not remove or insert the power plug with wet hands. Doing so could result in electric shock.
- Unplug the power cord if it is not used for a long time.
- Do not attempt to repair the power cord if it is broken or malfunctioning. When damaged it must be replaced, this should only be done by qualified personnel.

### **Especially for child safety**

- Don't allow children to climb on or play with the monitor.
- Don't place the monitor above furniture that can easily be used as steps.
- Remember that children can become excited while watching a program, especially on a "larger than life" monitor. Care should be taken to place or install the monitor where it cannot be pushed, pulled over, or knocked down.
- Care should be taken to route all cords and cables connected to the monitor so that they cannot be pulled or grabbed by curious children.

## Connections

 Be sure to turn off the main power switch and disconnect the plug from the power outlet before connecting/disconnecting cables. Also, read the manual of the equipment to be connected.

Be careful not to confuse the input terminal with the output terminal when connecting cables. Accidentally reversing cables connected to the input and output terminals may cause malfunctions and other problems.

In the case of USB fault condition, maximum current is below 5A.

## Positioning

If a monitor is positioned in an unstable or inclined location, it can be potentially hazardous due to falling. Many injuries, particularly to children, can be avoided by taking simple pre-cautions such as:

- Using fixing devices like wall mount brackets recommended or supplied by the manufacturer.
- Educating children about the dangers of climbing on furniture to reach the monitor or its controls. If your existing product is being retained and relocated, the same considerations as above should be applied

## Transport and Shipping

- Your device must be kept in its original package to protect from damage to its accessories during transport and shipping.
- Keep the product in normal position during transport.
- Do not drop the device during transport and protect it against impacts.
- Damages and faults that occur during transport after the delivery of the appliance to the customer are not included in the warranty cover.
- Product transportation, installation, repair and servicing must be done by qualified technical service personnel.

## Intended Use

- This product is intended to be used in public places such as schools, offices, theatres, places of worship.
- Product is only suitable for connecting commercial mains socket outlets. Do not connect product industrial socket outlets.

## Foreseeable misuse and incorrect use

- For apparatus intended to be used in vehicles, ships or aircraft or at altitudes exceeding 5000m above sea level, for outdoor use or in general for the application other than mentioned in user manual additional requirements may be necessary.



**CAUTION**



Do not leave a static image displayed for prolonged period of time. If a static image is displayed continuously for a long period of time, that image may cause image sticking on the display. This condition is not permanent, but may require a considerable amount of operational display time to dissipate, depending upon the degree of image stick. 120 minutes of continuous motion display will eliminate most image sticking effects at normal room temperature (not lower than 10 C).

As the nature of the TFT technology, you may see some amount of bright, dark, red, green and blue dots and sparklings on the screen, those do not affect the performance of the computer and are not accepted as a defect.

## Warning

This is a class A. In a domestic environment this may cause radio interference in which case the user may be required to take adequate measures.

## BATTERY SAFETY GUIDELINES

Used correctly, domestic batteries are a safe and dependable source of portable power. Problems can occur if they are misused or abused resulting in leakage or, in extreme cases, fire or explosion.

Here are some simple guidelines to safe battery use designed to eliminate any such problems.

- Take care to fit your batteries correctly, observing the plus and minus marks on the battery and appliance. Incorrect fitting can cause leakage or, in extreme cases, fire or even an explosion.
- Replace the whole set of batteries at one time, taking care not to mix old and new batteries or batteries of different types, since this can result in leakage or, in extreme cases, fire or even an explosion.
- Store unused batteries in their packaging and away from metal objects which may cause a short-circuit resulting in leakage or, in extreme cases, fire or even an explosion.

- Remove dead batteries from equipment and all batteries from equipment you know you are not going to use for a long time. Otherwise the batteries may leak and cause damage.
- Batteries must not be exposed to excessive heat such as sunshine, fire or the like.
- Never dispose of batteries in fire or with hazardous or flammable materials as this can cause them to explode. Please recycle dead batteries; do not put with the normal household waste.
- Never attempt to recharge ordinary batteries, either in a charger or by applying heat to them. They may leak, cause fire or even explode. There are special rechargeable batteries which are clearly marked as such.
- Supervise children if they are replacing batteries themselves in order to ensure these guidelines are followed.
- Do not ingest the battery, Chemical Burn Hazard.
- This product or the accessories supplied with the product may contain a coin/button cell battery. If the coin/button cell battery is swallowed, it can cause severe internal burns in just 2 hours and can lead to death.
- Remember that small button cell batteries such as used in some hearing aids, toys, games and other appliances, are easily swallowed by young children and this can be dangerous.
- Keep new and used batteries away from children.
- Make sure battery compartments are secure. If the battery compartment does not close securely, stop using the product and keep it away from children.
- Seek immediate medical attention if you believe batteries might have been swallowed or placed inside any part of the body.
- If leaked battery fluid gets on your skin or clothing, rinse immediately and thoroughly. If it gets into your eye, bathe your eye well rather than rubbing and seek medical treatment immediately. Leaked battery fluid that gets into your eye or your clothing may cause a skin irritation or damage your eye.

## CAUTION

RISK OF EXPLOSION IF BATTERY IS REPLACED BY AN INCORRECT TYPE. DISPOSE OF USED BATTERIES ACCORDING TO THE INSTRUCTIONS.

## Markings on the Product

The following symbols are used **on the product** as a marker for restrictions and precautions and safety instructions. Each explanation shall be considered where the product bears related marking only. Note such information for security reasons.



**Class II Equipment:** This appliance is designed in such a way that it does not require a safety connection to electrical earth.



**Class II Equipment With Functional Earthing:** This appliance is designed in such a way that it does not require a safety connection to electrical earth, the earth connection is used for functional purposes.



**Protective Earth Connection:** The marked terminal is intended for connection of the protective earthing conductor associated with the supply wiring.



**Hazardous Live Terminal:** The marked terminal(s) is/are hazardous live under normal operating conditions.



**Caution, See Operating Instructions:** The marked area(s) contain(s) user replaceable coin or button cell batteries.

Any issues which are caused by customer mis-adjustment of any software including the operating system are not covered by the warranty.

Depending on the model you buy, the actual appearance of the product may differ from the images used in this manual.

## Introduction

This interactive Display is designed for use in educational institutions or in the business world. It provides convenience with various software programs and applications that can be used in these areas.

## General View

Please note that connection ports and other features shown here may vary depending on the model of your Display.

### Front Side

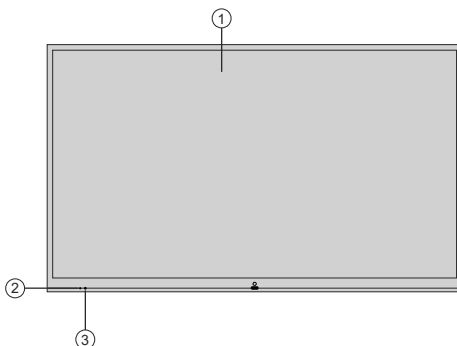

1. LCD Panel
2. Standby LED
3. IR Receiver

**Note:** The USB (2.0, for touch only) port is for use with the front HDMI video signal connection. Refer to the **Embedded Infrared Overlay Touch Screen** section for more information.

### Rear Side (A) (May vary depending on model)

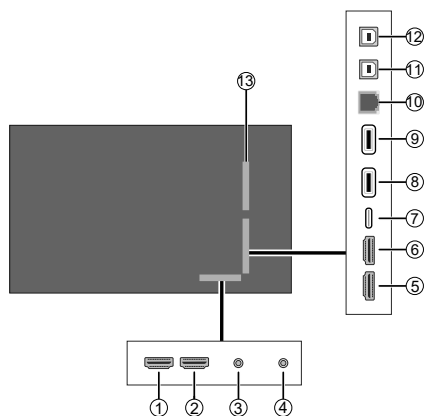

1. HDMI1 In
2. HDMI Out
3. Headphone/Line Out
4. RS232 (3,5 mm)
5. HDMI2 In
6. HDMI3 In
7. USB Type-C (\*)
8. USB (3.0) (\*)
9. USB (3.0) (\*)
10. Ethernet In
11. USB Type-B (for touch only)
12. USB Type-B (for touch only)
13. Connection slot for PC (OPS) Module

(\*) Supported file formats are listed in the **Supported Media Formats from USB** section.

**Note:** The USB Type-B (for touch only) ports are for use with HDMI1, HDMI2, HDMI3, and DP video signal connections (11. - HDMI1 and DP; 12. - HDMI2 and HDMI3). Refer to the **Embedded Infrared Overlay Touch Screen** section for more information.



## Rear Side (B) (May vary depending on model)

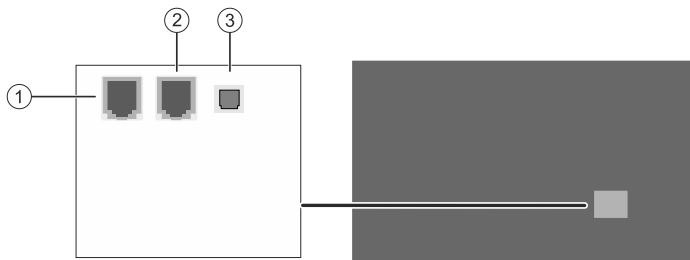

1. RJ12 (sensor box use)
2. RJ12 (service use only)
3. SPDIF Optical Out

## Control Buttons on the Display

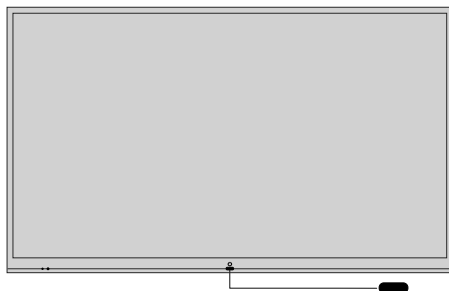

**Note:** The position of the control button may differ depending on the model.

Your Display has a single control button. This button allows you to turn the Display on and off.

### **Standby State**

Turn on

### **Operating State**

Quick standby (\*) / Standby (\*)

(\*) If the **Power Mode** option (to be found in the **Display Settings > Options > Power Up Settings** menu) is turned off (**Eco mode**), the Display will switch into standby mode when the **Standby** button is pressed.

**Note:** Main menu OSD cannot be displayed via control buttons.

## Turning the Display On/Off

### **Connect power**

**IMPORTANT: The Display is designed to operate on 110-240V AC, 50/60 Hz socket.**

After unpacking, allow the Display to reach the ambient room temperature before you connect it to the mains. Plug the power cord into the mains socket outlet.

### **For models with detachable power cord**

Plug one end (female connector - C13) of the supplied detachable power cord into the power cord inlet (AC IN) on the rear side of the Display. Then plug the other end of the power cord into the mains socket outlet.



Turn on the power switch on the Display - position "1" (). The Display will switch into standby mode and the power LED will light up.

### To switch on the Display

If the Display is in standby mode or quick standby mode, the power LED lights up. To switch on the Display either press the **Standby** button on the remote control or the control button on the front side of the Display. The Display will then switch on.

### To switch the Display into standby mode

In order to switch the Display into standby mode press and hold the **Standby** button on the remote control or the control button on the Display. **Power off** dialogue will appear on the screen. The **OK** option will be highlighted. Press the **OK** button on the remote control or the control button on the Display. The Display will switch into standby mode.

### To switch the Display into quick standby mode

In order to switch the Display into quick standby mode either press the **Standby** button on the remote control or the control button on the Display. Press the button again to go back to operating mode.

**Note:** If the **Power Mode** option (to be found in the **Display Settings > Options > Power Up Settings** menu) is turned off (**Eco mode**), the Display will switch into standby mode when the **Standby** button or the control button is pressed.

### To switch off the Display



Turn off the power switch on the Display - position "2" (). The Display will switch off. To power down the Display completely, unplug the power cord from the mains socket.

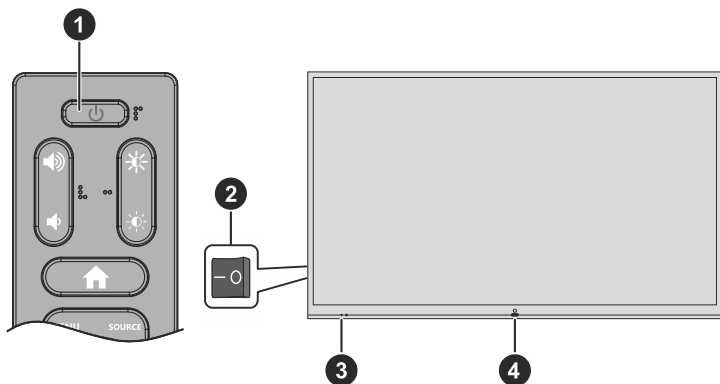

1. Standby Button
2. Power Switch (\*)
3. Power LED
4. Control Button

(\*) The location of the power switch and control button may differ depending on the model of your Display.

Power LED Status	Status of the Display
Not lit	Power on (operating mode)
Lit	Power off (standby mode, quick standby mode)
Flashing (slow)	Turning on or off (standby mode)
Flashing (fast)	Software update

## Embedded Infrared Overlay Touch Screen

Infrared Overlay Touch Screen adds touch screen feature to your Display. The Touch Screen is connected internally to the Display. If you switch the Display's source to the embedded OPS (if available), touch screen feature can be used with the OPS. It can also be used with external source devices. In this case, the external source device should be connected to the Display a USB (type-B) to cable. Connect the external source device as shown in the example connection below. Touch screen will become functional after a short period of time. The Touch Screen can also be used with the Internet Browser (if available) which can be launched from the Displays menu.

The Touch Screen is HID compliant. Windows, Linux, Mac and Android operating systems support HIDs. But in some cases a driver/patch may be required in order to use the touch screen with an external source device. In this case, the required driver/patch should be installed onto the external source device. Otherwise the Touch Screen may not work properly. Refer to the user manual of the source device for further information.

If the operating system of the source device does not recognise the touch screen after the connection has been established (a message may appear on the screen of the source device stating that the USB device is not recognised), switch to a different input source or turn the display off and on again refer to the turning the Display On/Off section if you need further information on the buttons on the Display and their functions.

Touch screen controls the currently displayed image on the screen of the Display. If an embedded OPS is being used the touch screen controls the embedded OPS. If an external source device is connected via HDMI or DP (\*) and the source is selected accordingly, then the connected device will be controlled.

(\*) Availability depends on the model

### Example Connection (External PC)

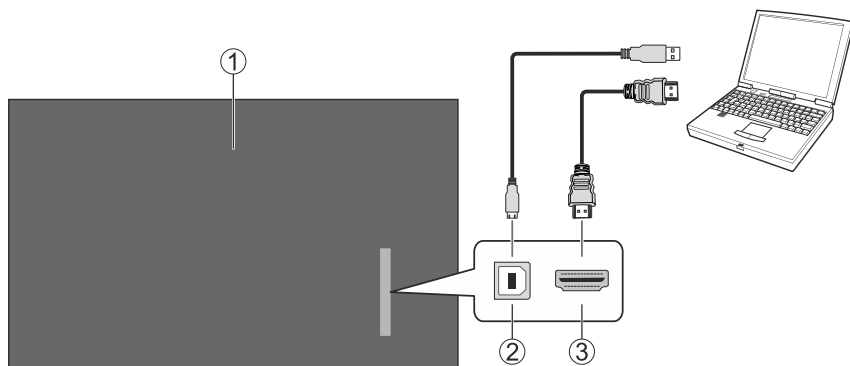

1. Rear side of the Display
2. USB Type-B (for touch only)
3. HDMI In

In the undermentioned circumstances the coordinates of the Touch Screen and Display's screen may need to be accurately matched by calibration.

- After the first time you have installed the touch screen driver software or patch.
- If inconsistency is occurred between the mouse and your finger action.
- After replacing the Touch Screen or Display.
- If the resolution of the Display is changed.

**Note:** If any driver/patch is missing or you require technical support, please contact your retailer.

## Remote Control

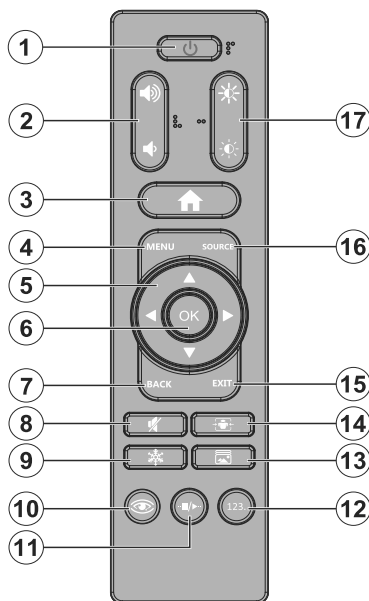

1. **Standby:** Quick Standby / Standby / On
2. **Volume +/-:** Increases or decreases the volume
3. **Home:** Opens the Home Screen
4. **Menu:** Opens the **Display Settings** menu
5. **Directional buttons:** Navigates menus, setting options, moves the focus or cursor, etc.
6. **OK:** Confirms user selections, enters to sub-menus
7. **Back:** Returns to previous screen, goes one step back, closes open windows
8. **Mute:** Completely turns off the volume of the Display
9. **Freeze:** Freezes the currently displayed image on the screen. Press again to cancel the freeze function. You can also press the **Back** button to quit freeze mode or tap on the **Unfreeze** button on the screen
10. **Eye Care:** Enables or disables eye care function. Basically the **Colour Temperature** will be set to **Warm** when this button is pressed
11. **Pause/Play:** Pauses the media being played / Resumes playing the paused media
12. **Numeric keyboard:** Opens a numeric keyboard. Use this virtual keyboard to enter a number in the text box on the screen
13. **Picture Mode:** Opens the picture mode selection menu. Press the button consecutively or use the Left and Right directional buttons to set
14. No function
15. **Exit:** Closes and exits from displayed menus or any running application, returns to previous screen, opens the Home Screen
16. **Source:** Opens the source selection menu
17. **Brightness +/-:** Increases or decreases the brightness of the screen

### Inserting the Batteries into the Remote

The remote may have a screw that secures the battery compartment cover onto the remote control first (or this may be in a separate bag). Remove the screw, if the cover is screwed on previously. Then remove the battery compartment cover to reveal the battery compartment. Insert two 1.5V - size **AAA** batteries. Make sure the (+) and (-) signs match (observing correct polarity). Do not mix old and new batteries. Replace only with same or equivalent type. Place the cover back on. Secure the cover again with the screw, if any.

### Standby Button

Press and hold the **Standby** button on the remote control. **Power off** dialogue will appear on the screen. Highlight **OK** and press the **OK** button. The Display will switch into standby mode. Press briefly and release to switch the Display into quick standby mode or to switch on the Display when in quick standby or standby mode.

The behaviour of the Standby button will change depending on the **Power Mode** option setting in the **Display Settings > Options > Power Up Settings** menu. If this option is turned off (**Eco mode**), the Display will switch into standby mode when the **Standby** button is pressed.

## General Use

The initial setup is not fully compatible with the touch screen. So it will be more convenient to use the remote control when performing initial setup process.

To interact with the user interface when on the Home Screen or when working in an application, tap, tap and hold or tap and drag with the included pen or your finger. The Display also supports multitouch gestures and more, so you can use two fingers to resize or rotate objects, zoom in and out, and two or more users can simultaneously write or draw while using the applications or annotation tool.

### Operation with the Remote Control

Press the **Home** button to display or return to the Home Screen. You can navigate through the elements situated on the Home Screen using the remote control buttons. Press a directional button first to start navigating on the Home Screen with the remote. Press the **Menu** button to display the **Display Settings** menu. Use the directional buttons to move the focus, proceed, adjust some settings and press **OK** to make selections in order to make changes, set your preferences, enter a sub-menu, launch an application, etc. Press the **Back** or **Exit** button to return to the previous menu screen or step, close a menu or exit an application, etc.

### Input Selection

Once you have connected external systems to your Display, you can switch to different input sources. Press the **Source** button on your remote control. Use the directional buttons to highlight a source option and press the **OK** button to switch to that source. Or expand the General Tools Bar on the Home Screen, then tap on the **Source** button. Available source options will be displayed. Tap on any input source option to switch to it.

### Adjusting the Volume and Brightness

You can adjust the volume and the brightness by using the **Volume +/-** and **Brightness +/-** buttons on the remote.

You can also adjust the volume and brightness using the dedicated sliders on the Settings Board. Tap on the **Settings** button on the General Tools Bar to display the Settings Board.

## Initial Setup

When turned on for the first time, initial setup should be performed. Follow the on-screen instructions to setup your Display. The installation wizard will guide you through the setup process. Use the directional buttons and the **OK** button on the remote to select, set, confirm and proceed. You can use the **Back** button on the remote or highlight the **Back** option at the bottom of the screen and press **OK** to go back to the previous steps and change your selections. You can also use the functionality of the touch screen to navigate through the initial setup process.

### 1. Language

The language selection options will be listed on the screen. Select the desired language from the list and press **OK** to continue.

### 2. Country

In the next step select your country from the list and press **OK** to continue.

### 3. PIN

At this point, you will be asked to define a PIN for security purposes. Highlight **New Pin** and press **OK**. Enter a four-digit PIN twice for confirmation using the virtual keyboard. You have to enter this PIN if you are asked to enter a PIN for any menu operation later. To skip this step without defining a PIN, highlight **Next** and press **OK**.

### 4. Display Operation Mode

The **Display Operation Mode** screen will be displayed next. For normal operation set the **Power Mode to Reactive**. Set to **Eco** for an energy-efficient operation. In this mode your Display's settings will be configured to reduce the energy consumption. Note that, in **Eco** mode, the UART/LAN Commands will not work if the Display is in standby state. You can also set your preferences for the **Energy Saving**, **HDMI Wake Up Enabled**, and **User Login** features here. Highlight **Next** and press **OK** to continue.

### 5. Network/Internet Settings

The **Network/Internet Settings** screen will be displayed. You can configure your Display's network settings using the options of this menu.

#### Wired Connection

Connect the Display to the network using an Ethernet cable before proceeding with the wired connection. Set the **Network Type** option to **Wired Device**.

#### Wireless Connection

Set the **Network Type** option to **Wireless Device**. The settings menu will change for the wireless connection. Refer to the **Network & Internet** section for detailed information on how to use this menu. After the settings are completed, press the **Back/Return** button to return to the initial setup. Highlight **Next** and press **OK** to continue.

#### Advanced Settings

Highlight **Advanced Settings** and press **OK**. You can use the options in this menu to change the IP and DNS settings of the Display. Highlight the required option and press **OK**. Select the items in the drop down menu and press **OK**. Use the virtual keyboard to enter the new values. Highlight **Save** and press **OK** to save the settings when finished.

#### Networked Standby Mode

You can also enable or disable the Networked Standby Mode feature by setting the related option accordingly. This is a standard that allows a device to be turned on or woken up by a network message when it is in standby mode. If you want your Display to consume less power in

standby mode, you can disable the **Networked Standby Mode** option by setting it to **Off**. Refer to the **Networked Standby Mode** section for more information.

The connection status information will be displayed at the bottom of the screen.

Refer to the **Network & Internet** and **Connectivity** sections if you need information on configuring a network connection and other available options. After the settings are completed highlight **Next** and press **OK** to continue.

#### 6. **Manufacturer Usage & Diagnostics**

You will be asked to give your consent to the collection of your data. Read the text on the screen for detailed information. Highlight **Accept** and press **OK** to give your consent. Highlight **Next** and press **OK** to proceed.

#### 7. **OTA Modes**

The **OTA Modes** screen will be displayed next. You can set your preference for an OTA upgrade. Highlight an option and press **OK** to make a selection. Read the text on the screen for more information on each option. Highlight **Finish** and press **OK** to complete the initial setup.

When the initial setup is completed Home Screen will be displayed. You can repeat the initial setup process and reset the Display's settings to the factory defaults anytime using the **First time installation** option in the **Display Settings > Options** menu. You can access the **Display Settings** menu by pressing the **Menu** button on the remote.

**Note:** You will be asked to enter the PIN to perform initial setup. If you didn't define a PIN during the initial setup, you can use the default PIN. Default PIN is set to **0000**. If you have defined a PIN during the initial setup or later via the Display menu, the default PIN will be **4725**.

## Home Screen

After the initial setup, the Display will open with the Home Screen. To be able to use the widgets, tools, applications and access the settings and user-specific content, login will be required if the User Login feature is enabled during the initial setup. Disable the User Login feature to have the default admin account automatically logged in after the initial setup. Refer to the **Login** and **Account Management System (AMS)** sections for more information. After you have logged in, the Home Screen of your user account will be displayed. Press the **Home** or **Exit** button to display or return to the Home Screen.

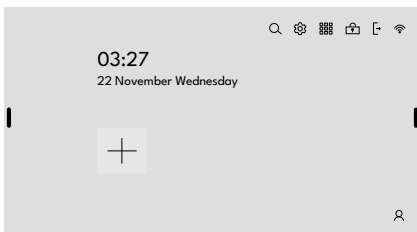

Following widgets will be available on the Home Screen:

#### In the upper right corner

- Search (🔍 - only if user logged in)
- Quick Settings (⚙️ - only if user logged in)
- All apps (📁 - only if user logged in)
- Lock (🔒 - only if user logged in)
- Log out (🚪 - only if user login is enabled)
- Wireless connection indicator

#### In the centre

- Time
- Date
- Edit (+) or favourite applications and edit (only if user logged in)
- Login (🔒 - only if user not logged in)

#### On the left and right sides

- General Tools Bars

## General Tools Bar

General Tools Bars are situated over the left and right edges of the screen. If not in use, the tool bars on the Home Screen will be hidden automatically. Tap on an empty area on the screen to reveal the hidden toggle buttons of the bars. The bars will appear in collapsed state. To expand or collapse a tool bar tap on the toggle button of that bar. The tool bars will always appear on top of all other content currently displayed on the screen. These toggle buttons and the bars can be dragged up and down along the edges of the bars/screen so you can see and tap on the content beneath. To use this function, tap and hold the toggle button or the dragging area at the bottom of the bar, drag it to the desired location without lifting your finger, and then release.

You can enable or disable the General Tools Bars using the related switches. Tap on the gear wheel widget on the Home Screen to display the Quick Settings Board. Tap on the **Show Right Bar** or **Show Left Bar** switch to enable or disable the related bar.

Following function buttons are included on the General Tools Bars:



**Toggle:** Expand or collapse the bar



**Source:** Display input source options



**Tools:** Open the Tools Board



**All Apps:** Display all applications installed on the Display



**Settings:** Open the Settings Board



**Recent Apps:** Display recently used applications



**Home:** Display Home Screen



**Back:** Return to previous screen, menu



**Drag:** Drag the bar along the edge of the screen

## Tools Board



Calculator



Chronometer



Timer



Palette



Freeze



Screenshot



Crop



Spotlight



Voting



Lock

Tools Board will be displayed when you tap on the **Tools** button on the General Tools Bar, if you are logged in previously. Otherwise login dialogue will be displayed.

Following function buttons will be included:

**Calculator:** Open calculator tool

**Chronometer:** Open chronometer tool

**Timer:** Open timer tool

**Palette:** Open quick palette tool

**Freeze:** Freeze the currently displayed picture on the screen. The General Tools Bars will not be shown and the Freeze Board will appear at the bottom of the screen. You can use the function buttons on this board to unfreeze the picture, open the quick palette tool, and take a screenshot. You can also drag the board left and right along the edge of the screen. To use this function, tap and hold the dragging area in the upper left corner of the board, drag it to the desired location without lifting your finger, and then release

**Screenshot:** Take a screenshot of the whole screen

**Crop:** Crop the screen and take a screenshot of the cropped part of the screen. Adjust the cropping area first and then tap on the check mark next to the **Crop** function button on the Tools Board. Tap on the cross mark to cancel

You can resize the cropping area by dragging the handles situated in the middle and the corners of it. To relocate the cropping area, tap and hold anywhere on this area, drag, and then release

**Spotlight:** Spotlight an area of the currently displayed picture on the screen. Tap and hold the spotlight area, drag it to the desired location, and then release. To resize the spotlight area, place your fingers on the screen and drag them away from or towards each other. You can also open the spotlight tool by tapping and holding anywhere on the screen with three fingertips

**Voting:** You can start a voting using this tool. When you tap on the **Voting** function button, the voting screen with a QR code will be displayed if the Display is connected to the Internet. To participate in the voting, participants with mobile devices (phones, tablets, etc.) that allow Internet-access should scan this code. Note that, the mobile devices should be connected to the same network as the Display. The QR code will direct the participants to a site where they can enter their user name for the voting. After entering the username, they should tap on the **Join** button. If the connection is successful, the "Success" message appears on the screen of the mobile device. There will also be an increase in the number of the connections on the voting screen if the connection is successful, (For example, if it is 0, it becomes 1). Afterwards, when the **Start Session** button on the voting screen is tapped, this page will be closed and a bar will appear at the bottom of the screen of the Display. **Start Voting**, **Show Result**, and **Quit** function buttons will be available on this bar. When the **Start Voting** button is tapped, a screen with 5 options (A, B, C, D, and E) appears on the mobile device. The participants

can select the desired option here. On the bar, the **Start Voting** button turns into the **Stop Voting** button. This button can be tapped, to end the voting. When the voting is stopped, the connected devices will no longer be able to vote. Afterwards, when the **Show Result** button is tapped, the voting results will be displayed. On this screen, the distribution of votes is displayed on a graph. This graph shows the number of votes and participants. On the second screen, the names of the participants and their votes can be seen. Tap on the **Return** button to close results. Tap on the **Quit** button on the bar to close the voting tool

**Lock:** Create a screen lock password / Lock the screen. You will need to enter this password to unlock the screen

When you open a tool, it will always be shown on top of all content and have drag and drop function. To use this function, tap and hold the centre of the palette tool or the title area of other tools, drag them to the desired location without lifting your finger, and then release.

To close a tool, tap on the X mark on the tool or the tool's function button on the Tools Board or the **Back** function button on the General Tools Bar.

**Note:** The screenshots will be saved into the **Pictures** folder on the internal memory of the Display. You can use the File Manager application to browse the files on the Display.

**Display Settings:** Open the Display Settings menu

**Lock:** Set a screen lock password for the active user account or change the existing one

**AMS:** Open AMS (Account Management System) settings. Will not be available if the user account does not have administrative rights (**User Role - Super Admin**). Refer to the **Account Management System (AMS)** section for more information

**Login Settings:** Open login settings. Will not be available if the active user account does not have administrative rights (**User Role - Super Admin**). Refer to the **Login** section for more information

**Password:** Change the password of the active user account

**Users:** Open the Users Board. Add or delete user accounts or edit the settings of the existing ones. Will not be available if the active user account does not have administrative rights (**User Role - Super Admin**)

**Wallpaper:** Set the wallpaper option of your choice for your TV. Highlight a wallpaper option and tap on the **Save** button.

## Settings Board

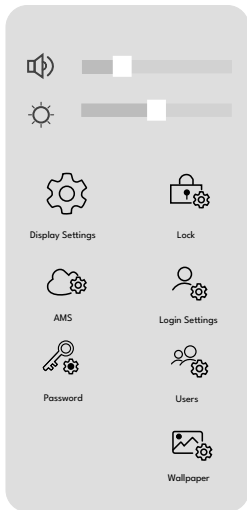

Settings Board will be displayed when you tap on the **Settings** button on the General Tools Bar, if you are logged in previously. Otherwise login dialogue will be displayed.

Following function buttons will be included:

**Volume Slider (🔊):** Adjust volume level

**Brightness Slider (☀️):** Adjust brightness level

## Users Board



Tap on the **Users** button on the Settings Board to display the Users Board. This button will not be available if the active user account does not have administrative rights.

Select the user account the settings of which you want to change or which you want to delete.

Following function buttons will be included:

**Add:** Add a new user account

**Edit:** Change the name and the role of the selected user account

**Delete:** Delete the selected user account

**Password:** Change the password of the selected user account



**Lock:** Set a screen lock password for the selected user account or change the existing one

The updated information will be saved on the Display. If the Display is connected to the Internet and operating in AMS active mode, the updated information will be saved in AMS.

## Quick Palette

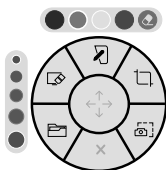

The dynamic (floating) Quick Palette mainly provides drawing functions. You can use the tools on it to change the pen's colour, pen's or eraser's thickness, take a screenshot, launch the white board application, and so on. You can open the Quick Palette by tapping and holding anywhere on

the screen with two fingertips.

Following function buttons will be included:

**Clear Screen** (☒): Clear all drawing on the screen

**White Board** (📄): Launch the Vdraw application

**Crop** (📏): Crop the screen and take a screenshot of the cropped part of the screen. Adjust the cropping area first and then tap on the check mark next to the cropping function button on the Quick Palette. Tap on the cross mark to cancel

You can resize the cropping area by dragging the handles situated in the middle and the corners of it. To relocate the cropping area, tap and hold anywhere on this area, drag, and then release

**Screenshot** (📷): Take a screenshot of the whole screen

**Close** (✕): Close Quick Palette

**File Manager** (📁): Launch the File Manager application

### Tip Size Bar, Colour Bar, Eraser

A thin and a thick white ring will appear around the circles to indicate the selected ones. The thin white ring will indicate the selected option for the pen and the thick white ring will indicate the selected option for the highlighter. If the selected option is the same for both the pen and the highlighter, only one thick ring will be visible.

Only a thick ring will be visible on the tip size bar to indicate the selected option for the eraser.

**Tip Size Bar:** Select the tip size of the pen, highlighter or eraser



**Colour Bar:** Select the colour of the pen or highlighter. Supported colours are Black, Red, Green and Blue



**Eraser** (🧽): Switch to eraser mode or switch back to pen/highlighter mode. This function button is situated on the colour bar

When switched to eraser mode you can use the pen or your fingers to erase the digital ink from the interactive screen. You can also use your palm to erase larger areas.

**Note:** The screenshots will be saved into the **Pictures** folder on the internal memory of the Display. You can use the File Manager application to browse the files on the Display.

## Drawing/Writing Over Screen

Please follow instructions below for drawing or writing on the screen.

- Select the desired colour and size for the pen or highlighter on the colour and tip size bar by tapping with the corresponding tip of the included pen. Use the thin tip for pen function and the thick tip for highlighter function
  - Draw/Write anywhere on the screen with the Stylus pen
- With the included Stylus pen, you can write and draw just like you would with an ordinary pen. The thin tip is for pen function and the thick tip is for highlight function.
- Tap on the Eraser (🧽) button to erase local areas.
  - Tap on the Clear Screen (☒) button to clear all drawings and writings on the screen at once
  - Tap on the Close (✕) button to close the Quick Palette

The drawings will not be erased when you close the Palette. They will appear again when the Quick Palette is opened again. This will not apply if the Display is switched off and back on again.

## Login

When the Display is turned on for the first time, an elementary Home Screen will be displayed after the initial setup is completed, if the User Login feature is enabled during the initial setup. As mentioned before, you will not be able to use the tools, applications and access the settings and create user-specific content if this is the case. Therefore, login will be required or you can disable the User Login feature during the initial setup to have the default admin account automatically logged in. Refer to the **User Login Feature** section below for more information.

You can log in as described below, if the user login feature is enabled.

- Tap on the **Login** widget (👤) situated in the centre of the Home Screen. The login dialogue will be displayed.

There are two ways to log in;

- Enter your user name and password credentials and tap on the **Login** button. Refer to the **Creating User Accounts** section below for more information on creating a user account.
- Use the default user name and password to log in. The default username and password are both set to **"admin"**.

Tap on the **Cancel** button to exit.

## User Login Feature

To use tools, applications and access the settings without logging in with your user account, you will need to disable the User Login feature during the initial setup. This will automatically log you into the default admin account. But if you did not disable this feature during the initial setup, you need to log in first as described above. After logging in, you can enable or disable this feature as described below.

- Tap on the **Settings** button on the General Tools Bar to display the Settings Board
- Tap on the **Login Settings** button. Login Settings screen will be displayed. Will not be available if the active user account does not have administrative rights (**User Role - Super Admin**)
- Tap on the **User Login** switch to enable or disable
- Tap on the **Save** button to complete

## Creating User Accounts

To create or add a user account the User Login feature should be enabled first as described above. To do that you need to log into an account with administrative rights. You can use the default username and password to do this. Enter **"admin"** for both.

Now you will be allowed to use the tool bars. Tap on the **Settings** button on the General Tools Bar to display the Settings Board. Then tap on the **Users** button. You will see the options to add, edit, and delete an account. Tap on the **Add** button to add a new user account. Enter the credentials and select the user role as **User** or **Super Admin** to determine the authorisation level of the account. When you are done, tap on the **Save** button.

**Super Admin** - Able to list users, add, edit and delete any user or update user password and lock password of any user

**User** - Able to edit own user password and lock password

The new user account information will be saved on the Display. If the Display is connected to the Internet and operating in AMS active mode, the information of the created user account will be saved in AMS and will be accessible on any Display registered to the same AMS.

## Account Management System (AMS)

AMS is a cloud-based system where all the data of the registered users and the Displays is stored. So, users can access their accounts and settings on any Display registered to the same AMS. Registering with AMS is not mandatory if a stand-alone operating Display is needed.

The Display supports operating both in AMS active and AMS passive mode. AMS passive mode is set by default.

## AMS Registration

It is required to have an Internet connection and the active user account should have administrative rights (**User Role - Super Admin**) in order to connect the Display to AMS. Please follow the instructions below:

- Connect the Display to the Internet  
Refer to the **Connectivity** section for more information
- Tap on the **AMS** button situated on the Settings Board. AMS Settings screen will be displayed. The **AMS** button is also situated on the Quick Settings Board. Tap on the **Quick Settings** widget on the Home Screen to display the board
- Tap on the **AMS Active** switch to enable the AMS
- Following fields will appear. These fields should be filled in to register with AMS. Enter the required information  
**Display Name:** A Name for your Display. Display information can be followed through AMS with this name  
**Account Management System URL:** Web URL of AMS  
**Account Management System Key:** Unique key for AMS
- When you are done filling these fields, tap on the **Save** button to complete the registration

Tap on the **Cancel** button to exit.

As a result, device and user settings will be downloaded from AMS, and users registered to AMS will become active in this Display. And the information of this Display and the user accounts created on it will be kept on AMS and will become accessible on any Display registered to the same AMS.

## Obtaining AMS URL and AMS Key

Please contact your AMS administrator for AMS URL and AMS Key information.

AMS administrator is required to follow the instructions below to get the AMS Key:

- Enter the AMS URL in the address bar of the web browser
- Enter the user name and the password in the related fields to log in
- Go to Settings > Configuration (AMS Settings Page - Configuration Tab)
- Find the AMS Secret Key field on the page

## Favourite Applications

You can select the desired applications for quick access. These apps will be accessible directly from the Home Screen.

To add an application to your favourites, tap on the plus sign (+) on the home screen. If an application is priorly added, tap on the plus sign at the bottom right corner of the favourite applications box to add an application or remove a present one. Available apps will be displayed in a box on the right side. Here you can select the applications you

want to add by tapping on them, and then tap on the **Add** button to add them. In the same way, you can select the applications that you want to remove from the favourite applications box and then tap on the trash can button to remove them. You can add or remove one or more of them by tapping on the apps in these boxes. When you are done, tap on the **Cancel** button.

If you want these changes to be applied to your registered account on AMS, the Display should be connected to the Internet and operating in AMS active mode.

## All Applications

Tap on the **All Apps** widget (☰) on the Home Screen or on the General Tools Bar. All applications installed on your Display will be listed here. You can launch any installed application using this screen.

Tap anywhere on the darkened area of the screen or the **Back** button on the General Tools Bar to exit.

**Note:** When using the VMeet application, make sure to connect the USB camera to the Display before you launch the application. Otherwise, you won't be able to turn on the camera during your meeting. If this is the case, close the app and relaunch it to use the camera.

## Recent Applications

Tap on the **Recent Apps** button on the General Tools Bar. The recently used applications that are still running in the background will be displayed. Swipe up or down to see all apps. You can switch between apps using this screen. Tap on an app to switch to it. To close an app, tap on the 'X' sign on the upper right corner of the app. You can close all recently used apps at once by tapping on the **Clear All** button.

Tap anywhere on the screen or the **Home** button on the General Tools Bar to exit.

## Display Settings Menu Content

You can configure the settings of your Display using the **Display Settings** menu. In order to access this menu, press the **Menu** button on the remote or tap on the **Quick Settings** widget (⚙️) on the Home Screen to display the Quick Settings Board and then tap on the **Display Settings** button. You can also use the **Display Settings** button situated on the Settings Board. Available options will be listed.

Note that some options in the **Display Settings** menu may not be available depending on the model of your Display and its features.

### Picture

**Picture Mode:** Set the picture mode to suit your preference or requirements. Picture mode can be set to one of these options: **Game, Sports, Signage, Natural, and Text.**

Some of the picture settings will be adjusted according to the selected picture mode.

**Energy Saving:** Set your preference for energy saving. If set to **Eco** the Display will adjust the energy consumption accordingly. Set to **Off** to turn this setting off. Some other picture settings may not be changed if this option is set to **Eco.**

When the Display is not in use, you can switch off or disconnect the Display from the mains plug to reduce or cut the energy consumption.

**Contrast:** Adjust the contrast value of the screen.

**Brightness:** Adjust the brightness value of the screen.

**Sharpness:** Adjust the sharpness value for the objects displayed on the screen.

**Colour:** Adjust the colour saturation value of the screen.

**Backlight:** Adjust the backlight level of the screen manually. This item will not be available if the **Energy Saving** option is set to **Eco.**

**Picture Zoom:** Set the aspect ratio of the screen. To make the image fit the screen exactly, you can select one of the predefined options according to your preference.

### Advanced Settings

**Dynamic Contrast:** Set your preference for the dynamic contrast ratio setting. **High, Medium, Low, and Off** options will be available.

**Microdimming:** Set your micro dimming preference. **High, Medium, Low, and Off** options will be available. While this feature is active, it will enhance contrast locally for each defined zone.

**Colour Space:** Set your colour space preference. **Auto, Rgb, and Yuv** options will be available.

**Colour Temperature:** Set your colour temperature preference. **Normal (9300K), Warm, and Cold** options will be available.

**Gamma Slider:** Adjust the light and dark balance manually.

**Noise Reduction:** Set your preference for noise reducing functionality. **High, Medium, Low, and Off** options will be available.

**Colour Shift:** Adjust the colour tone manually.

**Film Mode:** It is the function for 3:2 or 2:2 cadence detection for 24 fps film content and improves the side effects (like interlacing effect or judder) which are caused by these pull down methods. Set your Film Mode preference as **Auto** or turn it off by setting to **Off.**

**HDMI RGB Range:** This setting should be adjusted according to input RGB signal range on HDMI source. It can be limited range (16-235) or full range (0-255). Set your HDMI RGB range preference. **Auto, Full, and Limit** options will be available.

**Reset:** Reset the video settings to factory default settings.

**Note:** Adjusting some of the settings may not affect the picture on the launcher menu.

## Sound

**Speakers:** To hear the Display audio from the connected compatible audio device set to **External Audio System**. Set to **Display Speakers** to use the speakers of your Display for sound output.

**Dolby Audio Processing:** With Dolby Audio Processing, you can improve the sound quality of your Display. Press **OK** to see the options and set.

**Sound Mode:** Highlight the **Sound Mode** option and press **OK** to see the preset sound modes. **Smart, Music, Movie,** and **News** options will be available. Highlight the option you prefer and press **OK** to set.

**Volume Leveler:** Allows you to balance the sound levels. In this way, you are minimally affected by abnormal sound rises and falls. If the **Sound Mode** is set to **Smart**, this feature can be turned on. Highlight and press **OK** to turn on. Then adjust manually using the slider.

**Balance:** Adjust the left and right volume balance for speakers and headphones.

**Digital Output:** Set the digital sound output preference. **PCM, Bypass,** and **Auto** options will be available. Highlight the option you prefer and press **OK** to set.

**Note:** This option should be set to **PCM** instead of **Auto**, if the connected external audio device does not support DD. Otherwise, no sound will be heard from the connected device.

**AVL:** With this option, you can set the Display to automatically level out sudden volume differences. Typically at the beginning of adverts or when you are switching sources. Turn this option on/off by pressing **OK**.

**HDMI/ARC Latency:** Adjust the delay value for HDMI/ARC.

**Audio Output Latency:** Adjust the delay value for SPDIF.

**Dialogue Enhancer:** This feature provides sound postprocessing options for speech-gated dialogue enhancement. Highlight and press **OK** to turn on. Then adjust manually using the slider.

**Reset:** Reset the sound settings to factory default settings.

## Network & Internet

You can configure your Display's network settings using the options of this menu.

**Wi-Fi:** Turn the wireless LAN (WLAN) function on and off. Highlight and press **OK** to turn this function on and off.

**Note:** If the Display is connected to a wired network, unplug the Ethernet cable to allow wireless connection.

### Available networks

When the WLAN function is turned on, a few available wireless networks will be listed. Highlight **See all** and press **OK** to see all networks. Select one and press **OK** to connect.

You may be asked to enter a password to connect to the selected network, in case the network is password protected.

You can see the status of the connection under the name of your network. It will read 'Connected' if the connection is successful. Highlight the network that your Display is connected to and press **OK** to see the information on the connection, such as the Internet connection status (as **Connected - Not connected**), and if connected, the IP/MAC addresses and signal strength. You can also change the IP settings using the related option and delete the connected wireless network profile using the **Forget network** option here. You can set a proxy server using the related option under the **Other Options** caption.

**Note:** The IP Setting changes will not take immediate effect but becomes active after the Display is turned off and then back on again.

## Other Options

**Add new network:** Add networks with hidden SSID's (network name). You can use this option in order to connect to the hidden networks by entering their names manually. This item will not be available if the **Wi-Fi** option is not turned on.

**Proxy settings:** Set a HTTP proxy for browser manually. This proxy may not be used by other apps.

**Networked Standby Mode:** This is a standard that allows a device to be turned on or woken up by a network message when it is in standby mode. Highlight and press **OK** to turn this function on and off. Refer to the **Networked Standby Mode** section for more information.

**Internet Speed Test:** Start a speed test for the Internet connection. The test result will be displayed when completed.

## Ethernet

If the Ethernet (LAN) function under the **Ethernet** caption is turned on, you can see the LAN status (as **Connected - Not connected**) and also MAC/IP addresses here if the connection was successful. You can also change the IP settings using the related option. You can set a proxy server using the related option under the **Other Options** caption.

**Ethernet:** Turn the LAN function on and off. Highlight and press **OK** to turn this function on and off.

**Connected/Not connected:** Displays the status of the connection (via Ethernet), IP and MAC addresses.

**802.1x Settings:** Configure your Display's Ethernet port settings.

**IP settings:** Configure your Display's IP settings.

**Note:** The IP Setting changes will not take immediate effect but becomes active after the Display is turned off and then back on again.

## Options

### Device Info

Display device information menu options.

**Set ID:** Sets the device ID. Highlight this option and press the **Numeric keyboard** button (depends on the model) or numeric buttons on the remote control to set an ID number for your Display.

**Software Version:** Displays current software version. Press **OK** to open the update centre. In addition to the current software version, the last update date information can be found here. The **CHECK UPDATE** option will be highlighted. Press **OK** to start a manual search for a software update. To do this, your Display should be connected to the Internet. If any update is found, you can download and install the new software using the related options. Follow the on-screen instructions to complete the process.

**Serial Number:** Displays serial number of the Display. (Cannot be changed by the user)

**Model Name:** Displays model name of the Display. (Cannot be changed by the user)

**Save Model Information:** Copies the model information data of the Display to a connected USB device.

**Display Life Time:** Displays the lifetime of the Display in hours.

### Controls

**Pixel shift:** Enables or disables pixel shifting. This option can be used to avoid image retention (after image effects) that can occur when displaying fixed patterns or still images for long periods of time. If enabled, the picture and OSD (On-Screen Display) will be shifted at specified time intervals.

**No Signal:** Sets the behaviour preference of the Display, when no signal is detected from the currently set input source. **Failover**, **Input Search**, and **Disabled** options are available.

If **Failover** is selected the Display checks the connected USB device for available files to play. If no playable files are available or there is no USB device connected to the Display, the No Signal Image will be displayed. If there isn't any No Signal Image available, No Signal OSD will be displayed on the screen. The setting of the **USB Auto Play** option in the **Display Settings > System Settings > More** menu is not important, in Failover mode it will function anyway.

If **Input Search** is selected, available input sources will be listed. Highlight the options you want and press **OK** to select. The Display will search all selected input sources consecutively to find signal. If no signal is detected from other available sources, the Display will turn off automatically after completing a cycle.

**How to install No Signal Image**

Install the file you want to use onto the root directory of any USB storage device and name it as "NoSignalImage.png". Connect the USB storage device to the Display. Highlight the **USB Operations** option in the **Display Settings > Options > USB** menu and press **OK**.

**Control Button Lock:** Set to **On** to prohibit the use of the button/s on the Display.

**Remote Control Lock:** Set to **On** to inhibit the use of the remote. Remote control will function in standby mode independently from the setting of this option.

To turn this option off and be able to use the remote again, tap on the **Quick Settings** widget on the Home Screen to display the Quick Settings Board. Then tap on the **Display Settings** button. Enter the **Options > Controls** menu and set this option to **Off**.

You can also unlock the remote control by pressing the "Down / Volume + / Brightness + / Volume - / Brightness -" buttons consecutively.

**UART0:** Select ASCII/HEX protocol for UART 0. Default value is ASCII. There is no need to restart the Display after selection in order to work with the protocols correctly. If the selection is changed, the latest selected protocol will be preserved and started when the Display is booted up.

Note that ASCII/HEX selection is not working while debug logs are enabled. If it is wrongly changed to HEX while debug logs are enabled, revert the selection to ASCII and reboot the Display in order to correct the debug logs and the ASCII protocol behaviour.

Also note that HEX protocol will work with the baud rate value 19200 for UART 0.

**UART1:** Select ASCII/HEX protocol for UART 1. Default value is HEX. There is no need to restart the Display after selection in order to work with the protocols correctly. If the selection is changed, the latest selected protocol will be preserved and started when the Display is booted up.

Note that ASCII/HEX selection is always working as expected. It does not matter if the debug logs are enabled or not.

Also note that HEX protocol will work with the baud rate value 9600 for UART1.

**Embedded Touch:** Enable the functionality of the embedded touch screen for the selected option. If set to **Auto**, touch screen will be active for the current source (HDMI, DP, OPS or Display/Home). Refer to the **Embedded Infrared Overlay Touch Screen** section for more information.

**Note:** Availability of the input options may differ depending on the model of the Display.

**Microphone and Front USB (depends on the model):** Set your preference for the usage of the USB input/s and microphone located on the front side of the Display. **Display**, **OPS**, and **Auto** options are available. Selected option determines whether the microphone and front USB input/s are active.

**Display** - active for Home source

**OPS** - active for OPS source

**Auto** - active for current source (Home or OPS)

**Note:** Microphone and front USB may not be available depending on the model of your Display.

**Menu Lock:** You can block access to the **Display Settings** menu by setting this option to **All menus**. When you press the **Menu** button on the remote, tap on the **Display Settings** button on the Quick Settings Board or on the Settings Board, you will be asked to enter the PIN that you have defined during the initial setup process. If you didn't define a PIN during the initial setup, you can use the default PIN. Default PIN is set to **0000**. If you have defined a PIN during the initial setup or later via the Display menu, the default PIN will be **4725**. Set to **Off** to disable this function.

**Auto Source Switch:** If this option is enabled the Display will switch to the currently active HDMI source automatically when a device is connected to the Display through the HDMI1 or HDMI2 input socket. Set to **Enabled** to enable this feature.

When a source device connected to either HDMI1 or HDMI2 input socket is removed, the Display will switch to the other active HDMI source. If there is no other device connected to the Display and the **HDMI Wake Up Enabled** option is enabled, the Display will switch into the standby mode.

There is also a 3-second restriction for the successive connected HDMI sources. This means, second HDMI device must be plugged in 3 seconds after the first HDMI device is plugged in.

**Note:** This feature applies for HDMI1 and HDMI2 input sockets only. Refer to the **General View** section to see the HDMI inputs.

**Bluetooth:** Switches on or off the Bluetooth functionality. Set to **Enabled** to enable this feature.

**Note:** Previous pairing information will be lost if the **Bluetooth** option is disabled.

**Bluetooth Remotes & Accessories:** You can use wireless accessories, such as remote controls, headphones, keyboards or game controllers with your Display. Add devices to use them with your Display. Select this option and press **OK** to start searching available devices in order to pair them with your Display. If available highlight the **Add accessory** option and press **OK** to start the search. Set your device to pairing mode. Available devices will be recognised and listed or pairing request will be displayed. To start pairing, select your device from the list and press **OK**, or highlight **OK** and press **OK** when the pairing request appears.

Connected devices will also be listed here. Highlight the device and press **OK** to see available options. To unpair a device, highlight the **Unpair** option and press **OK**. Then select **OK** and press **OK** again to unpair the device from the Display. You can also change the name of a connected device. Highlight the **Change name** option and press **OK**. Use the virtual keyboard to change the name of the device.

If the device supports it, the device's current battery life remaining information will be displayed here as well.

If the **Bluetooth** option in the **Controls** menu is disabled, this option will become unavailable and appear as greyed out in the menu. Note that previous pairing information will be lost if the **Bluetooth** option is disabled.

## Power Up Settings

**Power Up Mode:** Configures the power up mode preference. **Always On**, **Standby**, and **Last State** options are available.

**Power Mode:** If this feature is enabled the Display can be turned on again with the RS232 and LAN commands if it is turned off through it. Press **OK** to enable or disable the feature.

Enabled - Reactive mode

Disabled - Eco mode

**HDMI Wake Up Enabled:** This feature works based on HDMI 5V or video signal and it will only work with a single HDMI source. When this signal is active the Display wakes up and when the signal is inactive the Display shuts down. **Disabled**, **5V**, and **Enabled** options are available. Set according to your preference. Highlight the option you prefer and press **OK** to enable. In order to use this feature in conjunction with the Auto Source Switch feature it is recommended to enable the **Auto Source Switch** option in the **Options > Controls** menu.

Enabled - works based on video signal

5V - works based on 5V signal

**Note:** Depending on the model of your Display, this feature may not be available, or if the **Power Mode** option is disabled (Eco mode), it may not work with the HDMI2 source.

## USB

**Clone to USB:** Copies the database files from the Display to a connected USB device.

**Clone from USB:** Copies the database files from a connected USB device to the Display.

**USB Operations:** Highlight and press **OK** to perform USB operations.

**USB Information:** Press **OK** to open the **USB Information** menu screen. Current total and free space information of the connected USB device will be displayed. You can also format the connected USB device as device storage using the **Format Disk** option in this menu (FAT32 format only) to extend the storage capacity of your Display. After doing this, that device will only be usable with the Display.

**IMPORTANT:** Formatting your USB storage device will erase ALL the data on it and its file system will be converted to FAT32.

**Safely Remove:** You can use this option to remove the devices connected to the USB inputs of the Display safely. Highlight this option and press **OK**. Wait for the message to be displayed on the screen and then remove your device.

Failure to do so, may cause problems when you connect your USB device to other devices and you might have to format your USB device.

## OPS Settings

Press **OK** to open the **OPS Settings** menu screen.

**OPS Status:** Displays whether the OPS module is on or off. Allows the change of status via soft PSON signal (0.5s).

**OPS Power:** Highlight and press **OK** to turn the OPS module on or off.

**Power Down:** Turns the OPS off via hard PSON signal (5s).

**Boot Signal:** Enables or disables sending of a PSON signal. The Display checks the status signal of the OPS at bootup in order to turn it on by sending a PSON signal if it is off. Some OPS's send incorrect information on their status during the bootup of the Display, so they seem to be on even though they are off. For such non-standard OPS's, this option must be enabled. In this case, a PSON signal will be sent for the OPS regardless of the received status information at bootup.

**Recovery Mode:** When this option is enabled and OPS is on, if there is no video for 10 seconds it resets hotplug. If there is no video available after 30 seconds it reboots OPS.

**OPS Always On:** When this option is enabled, the **Power Mode** option in the **Display Settings > Options > Power Up Settings** menu will be forced to enabled (**Reactive mode**) in the menu and OPS will not be set to standby.

**Power Off Mode:** Some OPS devices doesn't support power button feature. It can take a long time for the OPS to go into standby mode. In such cases, these menu options will be used to determine the behaviour of the Display. **Force** and **Normal** modes will be available. Highlight and press **OK** to switch between modes.

**Force:** If the OPS is not turned off when the standby button is pressed, the OPS will only wait 10 seconds to switch into standby mode.

**Normal:** The Display continues to show the message "OPS is shutting down" on the screen until the power is turned off. If the Display doesn't switch into standby mode for 20 seconds, a message will be displayed.

**SDM Version (depends on the model):** Displays the SDM version information.

## Volume Settings

**Volume Limit:** Sets the maximum value of the volume.

**Volume Limit (Headphone):** Sets the maximum value of the headphone volume.

**Startup Volume Enable:** Enables or disables the use of startup volume value which is set in the **Startup Volume Value** menu item. If this option is disabled, this menu item will be unavailable to be set. Press **OK** to enable or disable the feature.

**Startup Volume Value:** Sets the startup value of the volume.

**Fixed Volume Enable:** Enables or disables the use of fixed volume value which is set in the **Fixed Volume Value** menu item. If this option is disabled, this menu item will be unavailable to be set. Press **OK** to enable or disable the feature.

**Fixed Volume Value:** Sets the value of the volume to be fixed.

**Headphone Direct Volume:** When this feature is enabled, the sound is routed directly to the headphone output, without going through the Display's sound processing procedures.

## Reset to Default Values

**Reset:** Highlight this option and press the **OK** button on the remote to return the **Options** menu settings to factory defaults.

## First time installation

Highlight this option and press **OK** to repeat the initial setup process and reset the Display's settings to the factory defaults.

**Note:** You will be asked to enter the PIN to perform initial setup. If you didn't define a PIN during the initial setup, you can use the default PIN. Default PIN is set to **0000**. If you have defined a PIN during the initial setup or later via the Display menu, the default PIN will be **4725**.

## System Settings

**Language:** Set your OSD menu language preference.

**Date/Time:** Set the date and time options of your Display.

**Automatic date & time:** You can set your Display to automatically update the time and date data over the network. Turn this option off, if you want to manually set the date and time.

**Set date:** Set the date manually.

**Set time:** Set the time manually.

**Set time zone:** Set the time zone.

**Use 24-hour format:** Turn the 24-hour format on or off.

**Sources:** Enable or disable the source options. There will also be **Enhanced** and **Auto** options available for some sources, if your Display supports Ultra HD. The **Enhanced** option can be used for up to 4K@60Hz images, and the **Enabled** option can be used for up to 4K@30Hz images. Set to **Auto** to allow the Display to automatically switch between the **Enabled** and **Enhanced** options in case no image can be displayed due to incompatibility with the source device.

**Note:** HDMI cables which are longer than 5 metres and which are not HDMI certified can cause display problems. We recommend using a certified Premium High-Speed HDMI Cable. Source device, connection cable quality and other HDMI equipments used may affect performance.

Please refer to % <https://www.hdmi.org/resource/cables> (for finding the right cable)

**More**

**Menu Timeout:** Set your idle timeout duration preference for the menus.

**Standby Mode Led:** Enable or disable the functionality of the standby mode LED. If set to **Off** the standby mode LED will not light up when the Display is in standby mode.

**Software Upgrade:** Ensure that your Display has the latest software. Press **OK** to see the current software version and last update time. The **CHECK UPDATE** option will be highlighted. You can start a manual search for an update by pressing **OK**. To do this, your Display should be connected to the Internet. If any update is found, you can download and install the new software using the related options. Follow the on-screen instructions to complete the process.

**Auto Software Upgrade:** Enable or disable the automatic software upgrade functionality. **Disabled, Enabled,** and **Forced** options will be available. Set according to your preference.

**Country:** The country that was selected during the initial setup process will be shown.

**Auto Display Off:** Set your time preference for the Display to automatically go into standby mode when not being operated. This option can be set from 1 to 8 hours in steps of 1 hour. You can also disable this option by setting to **Off**.

**CEC:** Enable or disable the CEC functionality. Highlight the option of your choice and press **OK** to set.

**CEC Auto Power On:** This function allows the connected HDMI-CEC compatible device to turn on the Display and switch to its input source automatically. Highlight the option of your choice and press **OK** to set.

**USB Auto Play:** Using this option you can set your Display to start playing the media content installed on a removable device automatically. Refer to the **USB Auto Play Feature** section for detailed information.

**Legal Information:** Provides information about licences. Third party source, System WebView licences, and Consumer Information options will be available.

**Physical Keyboard Layout:** Select your keyboard type, configure remote controller input method preferences, and manage keyboard settings.

## Operating System Settings Menu Content

You can also configure some of the settings of your Display via the hidden operating system's **Settings** menu. In order to access this menu, press the **Menu** button and then the **Numeric keyboard** button on the remote and enter the **3-2-9-1** numbers using the numeric keyboard. Available options will be listed. You can also press the related button on the front side of the Display to access this menu (depends on the model). Refer to the **Control Buttons on**

the **Display** section if you need further information on the buttons on the Display and their functions.

## Network & Internet

You can configure your Display's network settings using the options of this menu. Refer to the **Display Settings Menu Content** section for more information.

## Apps

Using the options of this menu, you can manage the apps on your Display.

### Recently opened apps

You can display recently opened apps. Highlight **See all apps** and press **OK** to see all the apps installed on your Display. The amount of storage space that they needed will also be displayed. You can see the version of the app, open or force to stop the running of the app, uninstall a downloaded app, clear the data and cache, turn on/off the notifications, see the permissions and turn them on/off, etc. Highlight an app and press **OK** to see available options.

### Permissions

Manage the permissions and some other features of the apps.

**App permissions:** The apps will be sorted by permission type categories. You can enable and disable permissions for the apps from within these categories.

**Special app access:** Configure some app features and special permissions.

**Security & Restrictions:** Using the options of this menu you can allow or restrict installation of apps from sources other than the Google Play Store.

## Device Preferences

**About:** Check for system updates, change the device name, reset the Display to the factory defaults, and view system information such as network addresses, serial numbers, versions, etc. You can also view legal information here.

**Factory reset:** Reset all settings to the factory defaults. Highlight **Factory reset** and press **OK**. A confirmation message will be displayed, select **Factory reset** to proceed with resetting. A further confirmation message will be displayed, select **Erase everything** to factory reset the Display. The Display will switch off/on first and the initial setup will start. Select **Cancel** to exit.

**Note:** You may be asked to enter a PIN to proceed with the reset operation. Enter the PIN you have defined during the initial setup. If you didn't set a PIN during the initial setup, you can use the default PIN. The default PIN is set to **0000**. If you have defined a PIN during the initial setup or later via the Display menu, the default PIN will be **4725**.

**Date & Time:** Set the date and time options of your Display. You can set your Display to automatically update the time



and date data over the network. Set corresponding to your environment and preference. Disable by setting as **Off** if you want to manually change the date or time. Then set the date, time, time zone and hour format options.

**Keyboard:** Select your keyboard type, configure remote controller input method preferences, and manage keyboard settings.

## Display & Sound

### Display

**Text scaling:** Set your preferred text size.

**Match content frame rate:** Set your preference for the Display's behaviour related to adapting to the frame rate of the content.

**Advanced display settings:** Enter additional settings menu. You can enable or disable gaming mode, select your preference for the video formats, show or hide enabled and disabled formats.

### Sound

**System Sounds:** System sound is the sound played when navigating or selecting an item on the Display screen. Highlight this option and press **OK** to turn this function on or off.

**Advanced Sound Settings:** Select your preference for the sound formats, show or hide enabled and disabled formats.

**Storage:** View the total storage space status of the Display and connected devices if available, create free storage space by deleting cached data and uninstalling priority installed apps. To see detailed usage information, highlight the internal storage option or a connected device option and press **OK**. There will also be options for ejecting and setting up the connected USB storage devices as device storage.

#### Erase & format (Set up) as removable storage:

If you did priorly format your USB storage device as device storage, it will only be usable with your Display. You can use this option to format it again in order to use it with other devices. Before proceeding with the formatting, you may consider backing up the data on your device to your Display's internal storage or to another USB storage device using the **Back up apps** option. Otherwise, some apps may not work properly after formatting. Follow the on-screen instructions and read the information displayed on the screen before proceeding.

**Note:** Formatting the connected storage device will erase all data installed on it. Back up the files that you want to keep before you proceed with formatting the device.

**Erase & format (Set up) as device storage:** You can use the connected USB storage device to extend the storage capacity of your Display. After doing this, that device will only be usable with the Display. Follow the on-screen instructions and read the information displayed on the screen before proceeding.

**Note:** Formatting the connected storage device will erase all data installed on it. Back up the files that you want to keep before you proceed with formatting the device.

**Eject:** To keep your content safe, eject your USB storage device before you unplug it from your Display.

**Screen Saver:** Set the screensaver options for your Display. You can choose a screensaver, set a time for the screensaver to activate, or activate the screensaver.

**Location:** You can allow the use of the wireless connection to estimate the location, see the recent location requests and allow or restrict the listed apps to use your location information.

**Accessibility:** Configure **Captions, Text to speech, Accessibility shortcut** settings and turn **High contrast text** and **Audio description** on or off. Some of the caption settings may not be applied.

**Restart:** Restart the Display. Highlight and press **OK**. A confirmation message will be displayed, select **Restart** to proceed and **Cancel** to exit. The Display will first switch off and then switch on again.

## Bluetooth Remotes & Accessories

You can use wireless accessories, such as remote controls, headphones, keyboards or game controllers with your Display. Add devices to use them with your Display. Highlight this option and press **OK** to start searching available devices in order to pair them with your Display. If available highlight the **Add accessory** option and press **OK** to start the search. Set your device to pairing mode. Available devices will be recognised and listed or pairing request will be displayed. Select your device from the list or highlight **OK** when the pairing request is prompted and press **OK** to start pairing.

Connected devices will also be listed under this section. Highlight the device name and press **OK** to access detailed information on the device and additional settings listed below.

**Change name:** Change the name of the device.

**Unpair:** Unpair the device from the Display.

**Battery:** If the device supports it, the device's current battery life remaining information will be displayed here.

**Note:** This menu will not be available if the **Bluetooth** option in the **Display Settings > Options > Controls** menu is not set to **Enabled**.

## Installing Third Party Applications

Check if the installation of apps from sources other than the Play Store is allowed in the the operating system's **Settings > Apps > Security & Restrictions** menu. Highlight the **Unknown sources** option and press **OK**. If the checkbox next to the related app option in the **Install unknown apps** menu is not checked, highlight that option and press **OK**. Then follow the below mentioned steps in order to install a third party application. Refer to the

**Operating System Settings Menu Content** section if you need further information.

- Copy the file with the extension “.apk” onto a FAT formatted USB storage device
- Connect the USB storage device to one of the USB inputs on the Display
- Launch the **File Manager** app from the All Apps menu. Select your connected USB storage device and press **OK** to browse the content. Highlight the file with the extension “.apk” and press **OK**. Your permission will be asked. Select **Install** and press **OK** again to proceed

**Note:** Third party applications support is limited. Some functions of the application or properly launch may be affected.

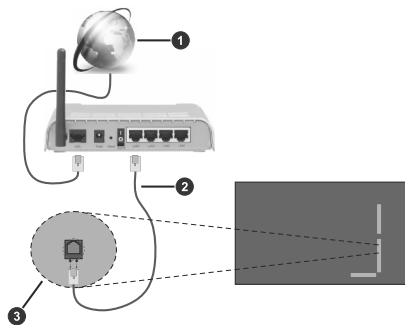

- 1 Broadband ISP connection
- 2 Ethernet (LAN) cable
- 3 Ethernet (LAN) input (on the rear side of the Display)

### To Connect to a Wireless Network

A wireless LAN modem/router is required to connect the Display to a wireless network. If the Display is connected to a wired network, unplug the Ethernet cable to allow wireless connection.

Highlight the **Wi-Fi** option in the **Network & Internet** menu and press **OK** to turn on the WLAN. Available networks will be listed. Select one and press **OK** to connect. You may be asked to enter a password to connect to the selected network, in case the network is password protected.

You can see the status of the connection under the name of your network. It will read 'Connected' if the connection is successful. Highlight your network under the **Available networks** caption in the **Network & Internet** menu and press **OK** to see the detailed information on the connection such as MAC and IP addresses. This way you can also access advanced settings for the wireless connection such as IP settings. You can also use the **Forget network** option here to delete the connected wireless network profile, so the Display will not connect to that network automatically if it is available when the WLAN option is turned on. You can set a proxy server using the related option under the **Other Options** caption.

**Note:** The IP Setting changes will not take immediate effect but becomes active after the Display is turned off and then back on again.

## Connectivity

To configure wired and wireless settings you should access the **Display Settings > Network & Internet** menu. Press the **Menu** button on the remote or tap on the **Quick Settings** widget (⚙️) on the Home Screen and then tap on the **Display Settings** button to view the **Display Settings** menu. You can also use the **Display Settings** button situated on the Settings Board.

The **Network & Internet** menu can also be accessed from the operating system's **Settings** menu. Refer to the **Operating System Settings Menu Content** section if you need further information.

### To Connect to a Wired Network

There is an Ethernet socket on the rear side of your Display. Connect your Display to your modem/router via this Ethernet socket using an Ethernet cable. Refer to the **General View** section on the first pages of this manual to see the location of the socket.

The status of the Internet connection under the **Ethernet** caption in the **Network & Internet** menu will read 'Connected'. The MAC and IP addresses will also be displayed under this caption. You can also set a proxy server and change the IP settings using the related options under the **Ethernet** and **Other Options** captions.

**Note:** The IP Setting changes will not take immediate effect but becomes active after the Display is turned off and then back on again.

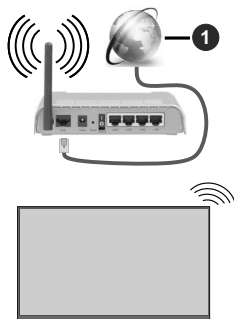

### 1 Broadband ISP connection

A network with hidden SSID (network name) can not be detected by other devices. If you want to connect to a network with hidden network name, highlight the **Add new network** option under the **Other options** caption and press **OK**. To connect to the network, enter its name, select the type of security and then enter the password if it is password-protected. You can also make your network's name visible by changing the settings via the modem's software.

A Wireless-N router (IEEE 802.11a/b/g/n/ac) with simultaneous 2.4 and 5 GHz bands is designed to increase bandwidth. These are optimised for smoother and faster HD video streaming, file transfers and wireless gaming.

The frequency and channel differ depending on the area.

The transmission speed differs depending on the distance and number of obstructions between the transmission products, the configuration of these products, the radio wave conditions, the line traffic and the products that you use. The transmission may also be cut off or may get disconnected depending on the radio wave conditions, DECT phones or any other WLAN 11b appliances. The standard values of the transmission speed are the theoretical maximum values for the wireless standards. They are not the actual speeds of data transmission.

The location where the transmission is most effective differs depending on the usage environment.

The Wireless feature of the Display supports 802.11 a,b,g,n & ac type modems. It is highly recommended that you should use the IEEE 802.11n communication protocol in order to avoid any possible problems while watching videos.

You must change your modem's SSID when there are any other modems around with the same SSID. You can encounter connection problems otherwise. Use a wired connection if you experience problems with a wireless connection.

A stable connection speed is required to play back streaming content. Use an Ethernet connection if the wireless LAN speed is unstable.

**Note:** Operating system allows only one network connection at a time. If the Display is connected to the network both wirelessly

and via Ethernet (wired), the Ethernet connection will take priority. Since if this is the case, a WLAN connection can not be established. Unplug the Ethernet cable to allow wireless connection.

## Networked Standby Mode

Networked Standby Mode is a standard that allows a device to be turned on or woken up by a network message (magic packet). This message is sent to the device by a program executed on a remote device connected to the same local area network, such as a smartphone.

To enable this feature the **Networked Standby Mode** option in the **Display Settings > Network & Internet** menu and the **Power Mode** option in the **Display Settings > Options > Power Up Settings** menu should be enabled (**Power Mode - Reactive**). It is necessary that both the device, from which the network message will be sent to the Display, and the Display are connected to the same network. All devices must support magic packet on the system from Access Points to the device which sends the magic packet and the device which receives the magic packet to wake-up. You can use any Networked Standby Mode software available for the operating system of your device in order to send magic packets.

In order to use this feature the Display and the remote device should be connected at least once while the Display is on. If the Display is powered off, the connection should be re-established, the next time it is switched on. Otherwise this feature will be unavailable. This does not apply, when the Display is switched into the standby mode.

### How to control functionality

- Enable the **Networked Standby Mode** feature from within the **Display Settings > Network & Internet** menu
- Connect your Display and the remote device, which will send the magic packets to the Display, to the same network
- Get the MAC address of your Display which will be needed in order to send magic packets. Refer to the **Connectivity** section for information on how to get the MAC address
- Switch the Display into standby mode
- Send magic packets to the MAC address of your Display by using mobile phones, Linux or Windows computers

Your Display should wake up after receiving magic packets.

## Media Player Applications

Tap on the **All Apps** widget (☰) on the Home Screen or on the General Tools Bar. The applications installed on your Display will be listed. Launch the application of your choice. **Gallery**, **Media Player** and **Music** applications can be used to play/display media files.

The application menus are not fully compatible with the touch screen. So it will be more convenient to use the remote control when navigating through these menus.

**Note:** Use the Media Player applications **Gallery**, **Media Player** and **Music** to play/display media files. It might not be possible to play/display media files using other applications such as OfficeSuite.

## Video Files

Launch the **Media Player** app from the All Apps menu. Select the connected USB storage device. Highlight a video file and press **OK** to play it back. You can use the media control buttons on the screen to control the video playback, and the buttons on the info bar to configure the settings. The media control buttons and the info bar will disappear after a certain period of time. Press **OK** to reveal them again.

**Pause/Play:** Pause and resume the playback.

**Back:** Return to the previous screen.

## Music Files

Launch the **Music** app from the All Apps menu.

You can use the tabs at the top of the screen to sort the files. Press **OK** to play back the highlighted music/audio file. Now Playing screen will be displayed. You can use the options here to control the media.

**Pause/Play:** Pause and resume the playback.

**Back:** Return to the previous screen.

## The Media Control Buttons on the Now Playing Screen

**Play List:** Display the now playing playlist.

**Shuffle:** Highlight and press **OK** to turn the shuffle option on or off. When the shuffle mode is on, all of the music files in the current playlist are played in a random order.

**Repeat:** Highlight and press **OK** to turn on or off the repeating option for the playing file or all files in the current playlist. Press **OK** consecutively to change the functionality. All music files in the current list or the currently playing file will be repeatedly played back.

**Pause/Play:** Highlight and press **OK** to pause and resume the playback.

**Start from beginning/Previous File:** Highlight and press **OK** to start the playback from the beginning or switch to the previous file in the list.

**Next File:** Highlight and press **OK** to switch to the next file in the list.

**Playback Progress Bar:** Highlight and use Left/Right directional buttons to fast forward or rewind the playback.

## Image Files

Launch the **Gallery** app from the All Apps menu.

Press **OK** to display the highlighted image file. On the upper left and right of the screen some options will be available. Using these options you can sort or group the files, change the viewing style, start a slideshow, etc. You will also be able to select the files, then make the selected files available offline, share them via short-range wireless connection

(depends on the model), rotate left/right or refresh the screen or access more settings using the related options.

When you start a slide show, all image files in the current folder will be displayed in an infinite loop. Press the **OK** or **Return/Back** button to stop the slide show.

**Pause/Play:** Start a slide show.

**Back:** Return to the previous screen.

## From USB Connection

**IMPORTANT!** Back up the files on your USB storage devices before connecting them to the Display. Manufacturer will not be responsible for any file damage or data loss. Certain types of USB devices (e.g. MP3 Players) or USB hard disk drives/memory sticks may not be compatible with this Display.

You can view your photos or play your music and video files installed on a connected USB storage device on the Display. Plug in the USB storage device to one of the USB inputs on the Display.

Launch one of the **Gallery**, **Media Player** and **Music** applications from the All Apps menu. Highlight a media file and press the **OK** button. Refer to the related section above for more information on using the apps.

**Note:** Wait a little while before each plugging and unplugging as the player may still be reading files. It is recommended to use the **Safely Remove** option in the **Display Settings > Options > USB** menu. Failure to do so may cause physical damage to the USB player and the USB device itself. Do not pull out your drive while playing a file.

## USB Auto Play Feature

This feature is used to start playing the media content installed on a removable device automatically. It uses the media playing applications. The media content types have different priorities in order to be played. The reducing priority order is as Image and Video. That means, if there is image content in the root directory of the removable device, the **Gallery** app will play the images in a sequence (in file name order). The Display will then check for video content. If any video file is available, the **Media Player** app will play the videos. All available files are played back in an endless loop.

This feature will only work if all of the following circumstances occur:

- The USB device is plugged in.
- The **USB Auto Play** option is set to **On**. It can be found in the **Display Settings > System Settings > More** menu.

## CEC and CEC RC Passthrough

This function allows to control the CEC-enabled devices, that are connected through HDMI ports by using the remote control of the Display.

The **CEC** option in the **Display Settings > System Settings > More** menu should be set to **Enabled** at first. Press the **Source** button and select the HDMI input of the connected CEC device from the **Source** menu. When a new CEC source device is connected, it will be listed in the source menu with

its own name instead of the connected HDMI port's name (such as DVD Player, Recorder 1, etc.).

The Display remote is automatically able to perform the main functions after the connected HDMI source has been selected. To terminate this operation and control the Display via the remote again, set the **CEC** option in the **Display Settings > System Settings > More** menu to **Disabled**.

The Display also supports the ARC (Audio Return Channel) feature. This feature is an audio link meant to replace other cables between the Display and an audio system (A/V receiver or speaker system).

When ARC is active, the Display does not mute its other audio outputs automatically. You will need to decrease Display volume to zero manually if you wish to hear the ARC audio only (same as optical or co-axial digital audio outputs, availability depends on the model). If you want to change connected device's volume level, you should select that device from the source list. In that case volume control keys are directed to connected audio device.

### System Audio Control

Allows an Audio Amplifier/Receiver to be used with the Display. The volume can be controlled using the remote control of the Display. To activate this feature set the **Speakers** option in the **Display Settings > Sound** menu to **External Audio System**. The Display speakers will be muted and the sound of the watched source will be provided from the connected sound system.

**Note:** The audio device should support System Audio Control feature and **CEC** option should be set to **Enabled**.

## USB TYPE-C

Multiple protocols and power delivery up to 5V@3A are supported via USB-C port/s on your Display. USB Type-C features are compatible with the devices that meet the USB-Type-C-Specification. 4K video stream (if the source supports DP alternate mode), USB data transmission and 5V@3A power delivery are supported through the USB-C connection that handle the plug orientation.

**Note:** It is recommended to use Electronically Marked USB-C to USB-C cable for video stream over Type-C connection. Also e-marked USB-C to USB-A cable can be used for data transmission.

## HDMI Out

The HDMI port located on the rear bottom side of the Display functions as an output port (HDMI Out port). This port will not function as an input, thus no source devices should be connected to this port. Only the content received from the HDMI1 input port located also on the rear bottom side of the Display can be outputted from this port. The content received from other inputs can not be outputted. This is a default function and you can not disable/enable through any menu option. HDMI Out port will always function if a source device is connected to the HDMI1 input.

**Note:** Refer to the **General View** section on the first pages of this manual to see the location of the HDMI ports.

**Note:** In Reactive mode (when the Power Mode option in the Display Settings>Signage Settings>Power Up Settings menu is enabled), when making daisy chain connection via HDMI Output, the HDMI Wake Up Enabled option in the Power Up Settings menu should be set to Enabled to use the HDMI Wake Up feature.

## Real Time Clock (RTC)

Your Display has an RTC. It is used to maintain the real date and time information for a period of time if the energy supply is interrupted by separating the Display from the mains or by a power blackout. In this case the Display will use the date and time information stored in RTC.

- All time sources are able to override RTC date/time.
- Display tries to connect to the **NTP server** periodically (6 hours after last update) to get the current date and time information. If the Display successfully gets this information from the NTP server, it updates itself and RTC with the received date and time information. If the NTP server update fails, the Display uses RTC time and date to update itself.
- The RTC battery provides power to the integrated real-time clock and the calendar. Without any external power source, RTC is able to function for a minimum of 14 days.
- If RTC is used as time source, manual date-time set is enabled from the **Date/Time** option in the **Display Settings > System Settings** menu.

## Controlling With An External PC

You can control the Display from an external PC via RS-232 (COM port) or LAN (Ethernet port) on the PC. For instance, system source can be changed from remote computer. When a command is sent from the PC to the Display, the Display operates according to the received command and sends a response message to the PC.

### Equipment/Tools

- RS-232 (3.5mm) to RS-232 (male) cable or LAN cable (connected via router)
- USB to RS-232 (female) adapter
- Notebook or PC which has USB or LAN port
- Installed program on remote PC to send commands

In general, the commands are sent for operating the implemented functions via serial or LAN port and utility. A suitable utility can be used such as described below.

## Connecting to the Display (RS232 port)

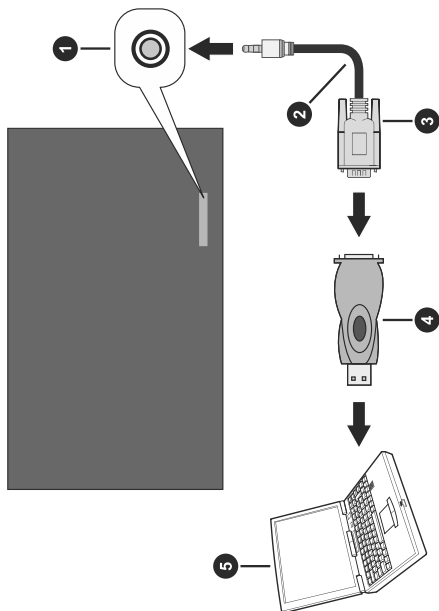

1. RS-232 Input Socket (3.5mm)
2. RS-232 to 3.5mm serial cable (commercially available)
3. To COM port
4. RS-232 to USB adapter
5. PC

Run the software and select **Serial** as **Connection Type**. Enter the Display's serial port in the field **Serial Line** (in the following example it is COM4) and "115200" in the field **Speed**. Then click the **Open** button.

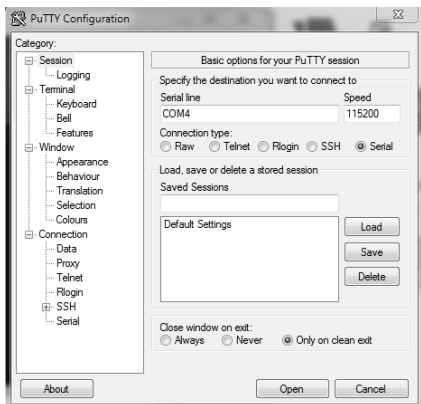

## Connecting to the Display (LAN port)

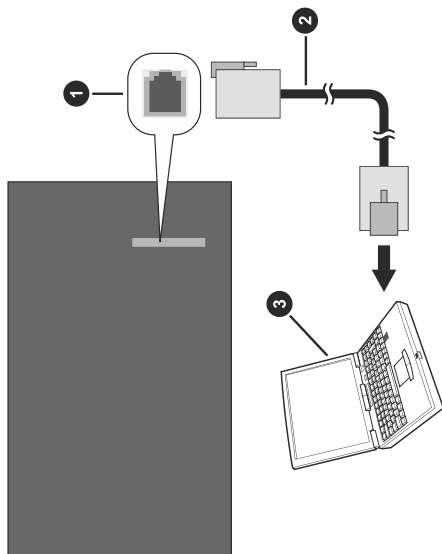

1. Ethernet port
2. Ethernet cable (commercially available)
3. PC

Run the software and enter the Display's IP address in the field **Host Name**. Enter "1986" as a default value in the field **Port**. Then select **Telnet** as **Connection type** and click the **Open** button.

**Note:** Refer to the **Connectivity** section of this manual for information on connecting the Display to a network and displaying the IP address of the Display.

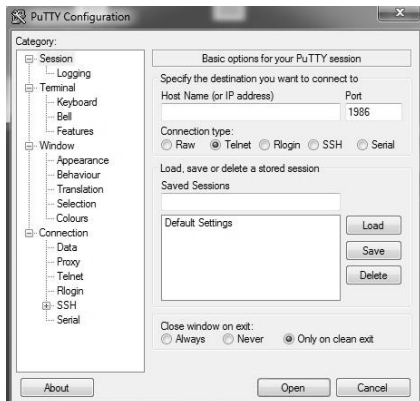

## RS232/LAN Command Table

### ADMIN PANEL COMMANDS

Command	Description	Parameter	Return
<b>TOF</b>	Turn off panel	no parameter	#Display will be sent to Active Standby state. or #Display is in Active Standby state already!
<b>RST</b>	Restart	no parameter or int (wait seconds until Restart)	#Display will be restarted
<b>STV</b>	Sets panel Volume, parameter value will ve set for volume level	integer (volume level)	#Volume set level= ...
<b>GTZ</b>	Get Time Zone	no parameter	#Timezone is ...
<b>CTZ</b>	Change Time Zone.	integer (gmt value )	#Timezone setup SUCCEEDED
<b>STL</b>	Set panel Language	string-int (please look at abbreviations of languages)	#Language changed to ... or #Wrong language selection.
<b>SMA</b>	Set mac address Note: This command is not available for MB230 platform. Instead, set_mac_address command can be used. Note2: This command only changes mac address of wired interface. Note3: Reboot needed.	string-int ( ex: eth0-00:09:df:86:34:25)	#SetMacAdress Successful #*FAILURE - Invalid mac address! #*FAILURE - Could not write MAC address!
<b>get_mac_address</b>	Get mac address	none	#*Hwaddr: mac_address - Succesfull
<b>GETMACADDRESS</b>	Gets mac address of selected network interface	none	#*Hwaddr: <mac_address> - Succesfull or #*Mac address could not be obtained
<b>GETGPIO</b>	Gets the GPIO's state	pin number(visit the GPIO List)	#*GPIO level is ...
<b>SETGPIOLOW</b>	Sets the GPIO's state to low	pin number(visit the GPIO List)	#*... is set to HIGH
<b>SETGPIOHIGH</b>	Gets the GPIO's state to high	pin number(visit the GPIO List)	#*... is set to LOW

<b>SELECTSOURCE</b>	Select source.	integer n (7 = HDMI1, 8 = HDMI2, 9 = HDMI3, 10 = HDMI4, 19 = DP, 20 = OPS, 26 = TYPE C )	#*Select external source: ...
<b>SSIP</b>	Set static IP, Default Gateway and SubnetMask addresses (seperate addresses with "-" character)	string ( ex: 192.168.0.15-10.0.90.5-255.255.255.0)	#IP address setting Succesfull

#### AUDIO COMMANDS

Command	Description	Parameter	Return
<b>VOLUME</b>	Set volume level.	integer n ( $0 \leq n \leq 100$ )	#*set volume to n
<b>GETVOLUME</b>	Volume level information.	no parameter	#*volume level is ...
<b>VOLUMEUP</b>	Increase Volume Level by 1 step (Until max volume)	no parameter	#*volume LEVEL is increased to ... or #*Volume level is at max value. You can not increase volume level further. Confirmed max volume level is ...
<b>VOLUMEDOWN</b>	Decrease Volume Level by 1 step	no parameter	#*volume LEVEL is decreased to .. or #*Volume level is at min value. You can not decrease volume level further
<b>SETEQMODE</b>	Set equalizer mode.	string n (Standart, Music, News, Theater, Game, Custom)	#*setEQMode() set to n or #*The above parameter should be one of Standard, Music, News, Theater, Game, Custom.
<b>GETEQMODE</b>	Get equalizer mode	no parameter	#*the equalizer mode is n Note: Above n is one of Standart, Music, News, Theater, Game, Custom
<b>GETMUTE</b>	Get mute status.	no parameter	#*MUTE OFF or #*MUTE ON
<b>SETMUTE</b>	Toggle mute status.	no parameter	#*MUTE OFF or #*MUTE ON
<b>SETBALANCE</b>	Set balance value.	integer n ( $-50 \leq n \leq 50$ )	#*set balance level to n or #*invalid balance level entered
<b>GETBALANCE</b>	Get balance value.	no parameter	#*balance level is ...



<b>SETDYNAMICBASS</b>	Set dynamic bass state.	integer n (0 = off, 1 = on)	#*set dynamic bass state to n
<b>GETDYNAMICBASS</b>	Get dynamic bass state.	no parameter	#*the dynamic bass state is ... (0 = off, 1= on)
<b>SETBASSGAIN</b>	Set bass gain	integer n (-6 <= n <= 6)	#*set bass gain to n or #*Incorrect sound system parameter entered
<b>GETBASSGAIN</b>	Get bass gain	no parameter	#*the bass gain level is n Note: Above n is -6 <= n <= 6
<b>SETSURROUNDSSOUND</b>	Set surround sound state.	integer n (0 = off, 1 = on)	#*set surround sound state to n
<b>SOUNDRESET</b>	Reset sound settings	no parameter	#*reset all sound settings

#### BROWSER COMMANDS

Command	Description	Parameter	Return
<b>OPENURL</b>	Starts the given URL and returns web page load status directly.	string	#*URL : ...
<b>GETURL</b>	Gets URL of the current page if the portal is active.	no parameter	#*URL : ...
<b>SETSETTINGSURL</b>	Sets the browser settings URL	string	#*Setting URL is set
<b>GETSETTINGSURL</b>	Gets the browser settings URL	no parameter	#*Setting URL is ...
<b>SETSTARTURL</b>	Sets the start URL	string	#*Start URL is set
<b>GETSTARTURL</b>	Gets the start URL	no parameter	#*Start URL is ...
<b>GETUSERAGENT</b>	Gets portal user agent.	no parameter	#*Current UA : ...
<b>CLEARCACHE</b>	Clear browser cache/ cookies (Private datas like web form)	no parameter	#*Browser cookies are cleared
<b>CLEARBROWSERDATA</b>	Clear browser data files like History, Bookmarks, Speed Dial and Configuration	no parameter	#*Browser data files are cleared
<b>GETCMSSTATUS</b>	Gets the CMS status	no parameter	#*Do cms status assignment with SETCMSSTATUS command or Returns the value of cms status
<b>SETCMSSTATUS</b>	Sets the CMS status	string parameter max. length of 255 characters	#*CMS status set to ... or #*NACK

<b>GETCMSPARAMS</b>	Gets the CMS parameters	no parameter	#*Do cms param assignment with SETCMSPARAMS command. or Returns the value of cms params
<b>SETCMSPARAMS</b>	Sets the CMS parameters	string parameter max. length of 255 characters	#*CMS params set to ... or #*NACK
<b>SETBROWSERDEBUG</b>	Sets the browser debug mode	string n (n = ON, n = OFF)	Browser debug is enabled. Open the following url with any chromium-based desktop browser: chrome://inspect or Browser debug is disabled
<b>SETBROWSECORS</b>	Set browser cors status to enable disable web security flag	int n (n = 0,1)	#*Browser cors is enabled or #*Browser cors is disabled
<b>GETBROWSECORS</b>	Get browser cors status	no parameter	#*Browser cors is enabled or #*Browser cors is disabled

#### FILE SYSTEM COMMANDS

Command	Description	Parameter	Return
<b>MP3PLAY</b>	Play MP3 audio file.	string-integer n Example: MP3PLAY audio.mp3	#*Playing audio : n
<b>MP3GETPLAYING</b>	Returns playing audio file.	no parameter	#*Playing /storage/2ECD-304C/audio.mp3
<b>VIDEOPLAY</b>	Play Video file.	string-integer n Example: VIDEOPLAY video.mp4	#*Playing video : n
<b>VIDEOGETPLAYING</b>	Returns playing video file.	no parameter	#*Playing /storage/2ECD-304C/video.mp4
<b>IMGSHOW</b>	Show image file.	string-integer n Example: IMGSHOW picture.jpg	#*Playing video : n
<b>IMAGEGETSHOWN</b>	Returns shown image file.	no parameter	#*Showing /storage/2ECD-304C/picture.jpg
<b>GETDISKFORMAT STATE</b>	Get format state of internal USB disk	no parameter	#*the disk is formatted. or #*the disk is not formatted. or #*No Internal USB is found.
<b>FORMATDISK</b>	Format the internal USB disk as FAT32	no parameter	#*formatting is succesful. or #*error while formatting. or #*No Internal USB is found.

#### GENERAL PANEL FUNCTIONS

Command	Description	Parameter	Return
<b>Led</b>	Turns the led on/off. (Used for setting the led status of current state)	integer n (0 = off, 1 = on)	#*Led is ON or #*Led is OFF
<b>GETLED</b>	Get led on/off state. (Used for getting the led status of current state)	no parameter	#*LED is on or #*LED is off
<b>SETSTANDBYLED</b>	Set Standby led status	string n (n = ON, n = OFF)	#*Standby Led is set to ON or #*Standby Led is set to OFF or #*Standby Led is not set (invalid input)
<b>SETSOURCE</b>	Set source as enable/ disable.	string n, integer b (n = HDMI1, n = HDMI2, n = HDMI3, n = HDMI4, n = DP, n = OPS, n = TYPE-C, n = WIDI ) (b = 1(enable), b = 0(disable))	#*Selected source n #*Enable/Disable state :b
<b>GETSOURCE</b>	Gets source.	Gets source.	#*source is ...
<b>SETSOURCENAME</b>	Changes source name with given index.	string n - integer m n = New source name m = Source index (HDMI1 = 5, HDMI2 = 8, HDMI3 = 9, HDMI4 = 10, DP = 6, OPS = 7, TYPE-C = 11, WIDI = 15) (Example=SETSOURCE NAME ASLI 5)	#* <old source name> source name changed with <new source name> or #*Source not available
<b>GETSOURCENAME</b>	Gets the source name with given index.	integer n n = Source index (HDMI1 = 5, HDMI2 = 8, HDMI3 = 9, HDMI4 = 10, DP = 6, OPS = 7, TYPE-C = 11, WIDI = 15)	#*Source name is ... or #*Source not available
<b>KEY</b>	Send key.	string-integer n (n = 0, n = 1, ....., n = up, ....., n = menu, .....ext.)	n key sent
<b>GETSWVERSION</b>	Returns the software version of panel.	no parameter	#*V...
<b>GETMODELNO</b>	Get model no.	no parameter	*Model no: ...
<b>SETMODELNO</b>	Set model no.	string-integer n	#*ACK or #*NACK
<b>GETSERIALNO</b>	Get serial no. (returns #*NACK if no serial number has been set)	no parameter	#*<Serial no> or #*NACK
<b>SETSERIALNO</b>	Set serial no.	string-integer n	#*ACK or #*NACK

SETFTIPIN	Set FTI PIN number	integer n (n is a four digit number)	#*FTI PIN was set to n
GETFTIPIN	Get FTI PIN number	no parameter	#*The FTI PIN is n
<b>CHANGELNG</b>	Change active language	integer n n = language( 0="Turkish", 1="English",2="Albanian", 3="Arabic",4="Azerbaijani", 5="Belarusian",6= "Bosnian",7="Bulgarian", 8="Czech",9="Danish", 10="Dutch",11="Estonian", 12="Finnish",13="French", 14="German",15="Gaelic", 16="Greek",17="Hebrew", 18="Croatian",19= "Hungarian",20="Italian", 21="Kazakh",22="Latvian", 23="Lithuanian", 24="Macedonian", 25="Norwegian", 26="Persian",27="Polish", 28="Portuguese", 29="Romanian"," 30=Russian", 31="Slovak",32= "Slovenian",33="Spanish", 34="Serbian",35="Swedish", 36="Thai",37="Ukranian", 38="Vietnamese" 39=","Japanese")  Example: CHANGELNG 0 (To set system language to Turkish)	#* [old language] language changed to n or #* Incorrect item parameter entered

<b>SETCOUNTRY</b>	Set country	string n Valid country strings are below: TURKEY, UK, ALBANIAN, AUSTRALIA, AUSTRIA, BELARUSIAN, BELGIUM, BULGARIA, COLOMBIA, CROATIA, CYPRUS, CZECH, DENMARK, ESTONIA, FINLAND, FRANCE, GERMANY, GREECE, HUNGARY, INDIA, IRAQ, IRELAND, ISRAEL, ITALY, JORDAN, LATVIA, LEBANON, LITHUANIA, LUXEMBOURG, MACEDONIA, MALTA, NETHERLANDS, NEW ZEALAND, NORWAY, IRAN, POLAND, PORTUGAL, ROMANIA, RUSSIA, SAUDI ARABIA, SERBIA, SLOVAKIA, SLOVENIA, SPAIN, SWEDEN, SWITZERLAND, THAILAND, UKRAINE, VIETNAM, JAPAN	#* setCountry() set to n or #*Incorrect item parameter entered
<b>GETCOUNTRY</b>	Get country	no parameter	#*COUNTRY IS : ...
<b>SETCUSTOMERNAME</b>	Change Customer name	string n ( n = Customer name)	#*Customer name is set as n
<b>GETCUSTOMER</b>	Get Customer name	no parameter	#*Customer: [CUSTOMER]#*
<b>BUILDINFO</b>	Reports the build info.	no parameter	#*Build info = ... #*Build Date = ...
<b>FACTORY</b>	Load factory settings to NVRAM. Settings are updated with defaults.	no parameter	#*Factory Settings were loaded to NVRAM.
<b>RESET</b>	Reset the device.	no parameter	#*Reset hardware
<b>MENUTIMEOUT</b>	Set menu time out mode.	integer n ( n = 0 , n = 15, n = 30, n = 45, n = 60)	#*set menu timeout mode to OFF or #*set menu timeout mode to 60 or #*Invalid menu timeout mode

<b>GETMENUTIMEOUT</b>	Get menu time out mode	no parameter	#*menu timeout mode is OFF or #*menu timeout mode is n or #*can not get menu timeout mode Note: Above n is one of (15, 30,45, 60)
<b>AUTOTVOFF</b>	Set auto panel off level.	integer n (0 = off, 1 = 1 HOUR, 2 = 2 HOUR, 3 = 3 HOUR, 4 = 4 HOUR, 5 = 5 HOUR, 6 = 6 HOUR, 7 = 7 HOUR, 8 = 8 HOUR )	#*set auto display off mode to n or #*set auto display off mode to OFF or #*auto display off must be Integer and between [0-8]
<b>GETAUTOTVOFF</b>	Get auto panel off mode.	no parameter	#*auto Display off is n or #*auto Display off is OFF
<b>GETSTANDBY</b>	Get standby on/off.	no parameter	#*standby off or #*standby on
<b>INTERACTIVE STANDBY</b>	Enter active standby state	no parameter	#*Display will be sent to Active Standby state! or #*Display is in Active Standby state already!
<b>EXITACTIVESTANDBY</b>	Exit active standby state	no parameter	#Display will be turned on! or #* Display is not in Active Standby state!
<b>GETTVLIFETIME</b>	Prints panel life time in minutes.	no parameter	#*Display Life Time: n
<b>SETPOWERONDELAY</b>	Set poweron delay level	integer n (0<=n<=20, delay is calculated as 100ms*n)	#*Power on delay set to ... ms or #*NACK
<b>GETPOWERONDELAY</b>	Get poweron delay level	no parameter	#*The power on delay is ... ms
<b>SIGNAGERESET</b>	Set all items in the signage settings menu to their default values.	no parameter	#*All signage settings set to default values
<b>SWOL</b>	Set Wake on Lan option	integer n ( n = 1 (enable), n = 0 (disable))	#*Wake on Lan is set to enable. or #*Wake on Lan is set to disable. or #*NACK

<b>GWOL</b>	Get Wake on Lan option	no parameter	#*Wake on Lan is enable. or #*Wake on Lan is disable.
<b>TIME</b>	Display the current date and time.	no parameter	Time = ...
<b>SETTIMEMODE</b>	Set time mode	string n ("auto", "manual")	#*set time mode to n or #*invalid input type
<b>GETTIMEMODE</b>	Get time mode	no parameter	#*time mode is n Note: Above n is "auto" or "manual".
<b>SETPOWERMODE</b>	Set Power Mode (SETPOWERMODE n)	string n (Eco,Reactive)	#*Set power mode to ... or #*Invalid power mode parameter (<Eco/Reactive>)
<b>GETPOWERMODE</b>	Returns Power Mode (Eco or Reactive)	no parameter	#*Power mode is ....
<b>GETCPU TEMPERATURE</b>	Gets cpu temperature	no parameter	#*cpu temperature is ...
<b>GETRAMUSAGE PERCENTAGE</b>	Gets ram usage percentage	no parameter	#*memory usage percentage is ... or #*can not get memory usage percentage
<b>set_video_output</b>	Switch on and off, all the Panel Supply Voltages and Video Signals	integer n (0 = off, 1 = on)	#*Video output is set to 0 or #*Video output is set to 1 or #*Invalid parameter
<b>screen_capture_usb</b>	Capture specified surface as png to USB stick.	integer n (0 for UI, 8 for video layer)	#*Screen capture is successfull. or #*Screen capture failed!
<b>VIDOFF</b>	Hides video.	no parameter	#*Video off.
<b>VIDON</b>	Shows video.	no parameter	#*Video on.
<b>GETVIDSTATE</b>	Get video state.	no parameter	#*Video is on or #*Video is off
<b>SETSCHEDULER</b>	enables/disables scheduler	string n (N_X, N_X) (N is scheduler number (1,2,3,4), X is "ON" or "OFF") ----- "SETSCHEDULER N_X" (SETSCHEDULER 1_OFF) (SETSCHEDULER 2_ON)	#*The scheduler Plan N (1,2,3,4) is set to X (ON, OFF) or #*Wrong parameter entered

<b>GETSCHEDULER</b>	gets scheduler enabled/ disabled	"GETSCHEDULER N" (N is scheduler number) ----- ----- "GETSCHEDULER 1"	#*The scheduler Plan N (1,2,3,4) is ... (ON, OFF) or #*Wrong parameter entered
<b>SETSCHEDULEOP</b>	sets scheduler parameters	string n ( schedulerplannumber_ onenabled_ontime_ offenabled_ offtime_days_ sourceorbrightness_value in format: A_B_hh:mm_C_ hh:mm_D_E_F ) A = 1, 2, 3, 4 B = 0, 1 C = 0, 1 D = XXXXXX (X = 0, 1) E = 0, 1 (0 = source, 1 = brightness) F; if E = 0, Available source names: Last Source USB DP OPS Type C HDMI 1 HDMI 2 HDMI 3 HDMI 4 if E = 1, backlight value = 0, 5, 10, 15, 20, 25, 30, 35, 40, 45, 50, 55, 60, 65, 70, 75, 80, 85, 90, 95, 100 ----- ----- "SETSCHEDULEOP number_ enabled_ontime_offenabled_ offtime_days_source" (SETSCHEDULEOP 4_1_ 08:00_1_22:00_0111110_0 _HDMI 1)	#*Schedule parameters are ... (set/not set).



<b>GETSCHEDULEOP</b>	gets scheduler parameters	<p>"GETSCHEDULEOP N" (N is scheduler number) N=1, 2, 3, 4 ----- GETSCHEDULEOP 1"</p>	<p>##Scheduler Plan N (1,2,3,4) on/off time, source and days are: ..... (hh:mm_hh:mm_source_days) or ##Scheduler Plan N (1,2,3,4) on/off time, backlight and days are: ..... (hh:mm_hh:mm_backlight_days) or ##Scheduler Plan N (1,2,3,4) is not set or ##Wrong parameter entered</p>
<b>STARTFTI</b>	start first time installation	no parameter	

#### MODE COMMANDS

Command	Description	Parameter	Return
<b>SETSTARTUPSOURCE</b>	Sets startup source which has been entered after power off on	integer n ( $1 \leq n \leq 7$ ) Source Index (n=1) DP (n=2) SLOT/OPS (n=3) TYPE C (n=4) HDMI1 (n=5) HDMI2 (n=6) HDMI3 (n=7) HDMI4	## The startup source is set to ... or ## Invalid startup source is entered.
<b>GETSTARTUPSOURCE</b>	Gets startup source which has been entered after power off on	no parameter	##The startup source is ...
<b>SETSTARTUPMODE</b>	Set start up mode	integer n ( $0 \leq n \leq 2$ ) (n = 0 => On, n = 1 => Standby, n = 2 => Last)	##The startup mode is ... or ##Invalid startup mode entered.
<b>GETSTARTUPMODE</b>	Get startup mode	no parameter	##The startup mode is ...
<b>SETPANELLOCK</b>	Set Panel lock availability (ON,OFF)	string n (ON, OFF)	##Set panel lock to ... or ##Invalid panel lock parameter
<b>GETPANELLOCK</b>	Get panel lock availability	no parameter	##The panel lock is ... or ##Panel lock has not been set yet.
<b>SETMAXVOLUME</b>	Set volume maximum level	integer n ( $0 \leq n \leq 100$ )	## Maximum volume limit is set to ... or ## Invalid volume parameter!
<b>GETMAXVOLUME</b>	Get volume maximum level	no parameter	##Maximum volume limit is ...
<b>GETMINVOLUME</b>	Get volume minimum level	no parameter	##The minimum volume is ...

<b>SETSTARTVOLUME</b>	Set startup volume	integer n (0 ≤ n ≤ 100)	#*Start up volume is set to ... or #*Volume can not be higher than maximum volume #*Invalid volume parameter!
<b>GETSTARTVOLUME</b>	Get startup volume	no parameter	#*Start up volume is ...

#### MEDIA BROWSER COMMANDS

Command	Description	Parameter	Return
<b>SETSLIDESHOW INTERVAL</b>	set slide show interval	integer n ( 5, 10, 15, 20, 25, 30 )	#*The slideshow interval is set to ... seconds
<b>GETSLIDESHOW INTERVAL</b>	get slide show interval	no parameter	#*The slideshow interval is ... seconds
<b>SETUSBAUTOPLAY</b>	set usb autoplay mode	string n (ON, OFF)	#*The USB autoplay is set to ... (ON, OFF)
<b>GETUSBAUTOPLAY</b>	get usb autoplay mode	no parameter	#*The USB autoplay is ... (1, 0)
<b>SETMBSUBTPOS</b>	set subtitle position	string n (Up, Down)	#*The subtitle position is set to ... (up, down)
<b>GETMBSUBTPOS</b>	get subtitle position	no parameter	#*The subtitle position is ... (up, down)
<b>SETMBSUBTFONTSIZE</b>	set subtitle font size	integer n	#*The media browser subtitle font size is set to ...
<b>GETMBSUBTFONTSIZE</b>	get subtitle font size	no parameter	#*The media browser subtitle font size is ... ( font size as in setter's parameters section)

#### SIGNAGE SETTINGS COMMANDS

Command	Description	Parameter	Return
<b>GETTOTALSPACE</b>	get total usb space	no parameter	#*The total space is ...
<b>GETFREESPACE</b>	get free usb space	no parameter	#*The free space is ...
<b>OPENDISPLAY SETTINGS</b>	Opens the Display Settings dialog	no parameter	#*Display Settings is opened
<b>SETMODE_EMBEDDED TOUCH</b>	Set the embedded touch mode	string (External,OPS,Display, TypeC,Auto)	#*Embedded touch mode is set to ***** or #*Embedded touch mode is not set (invalid input)
<b>SETMODE_WIFIBT</b>	Set the wifi&bt switch value	string wifibt string usb string (Display,OPS,Auto)	#*Wifi & BT Switch Mode is set to ***** or #*Wifi & BT Switch Mode is not set (invalid input)

<b>SETMODE_USB</b>	Set the Front&Internal USB status value	string usb string wifibt string (Display,OPS,Auto)	#*USB Mode is set to ***** or #*USB Mode is not set (invalid input)
<b>SETSIGNAGEID</b>	Set Signage ID	integer n	#*Set Signage ID Success. or #*Wrong parameter. Parameters must be integer
<b>GETSIGNAGEID</b>	Get Signage ID	no parameter	#*The signage ID is ... or #*The signage ID is 0 #*Do not forget to enter signage ID! (If return value is 0)
<b>SHOWSIGNAGEID</b>	display signage ID on screen	no parameter	#* Signage ID is ... or #* Signage ID is 0 #*Do not forget to enter signage ID! (If return value is 0)

#### NETWORK COMMANDS

Command	Description	Parameter	Return
<b>get_IP_address</b>	Get IP address of eth0 network interface. Usage: get_IP_address	no parameter	#*IPAddr: ...
<b>SAVEWIFIPROFILE</b>	Save access point to wifi_profile.	str-int ssid, bssid key	Profile saved. or Number of profiles exceeds the maximum number to be stored.
<b>Wifi</b>	checks if given SSID wifi is found or not and returns Pass or Fail.	str-int ssid	#*Pass or #*FAIL
<b>GETNETWORKTYPE</b>	get network type (eg. GETNETWORKTYPE)	no parameter	#*the network type is <network-type>
<b>SETSUBNETMASK</b>	set subnet mask (subnet mask value should be of format nnn.nnn.nnn.nnn) (eg. SETSUBNETMASK nnn.nnn.nnn.nnn)	string "nnn.nnn.nnn.nnn"	#*set subnet mask: nnn.nnn.nnn.nnn or #*setting subnet mask is failed
<b>GETSUBNETMASK</b>	get subnet mask (eg. GETSUBNETMASK)	no parameter	#*the subnet mask is nnn.nnn.nnn.nnn
<b>SETDEFAULTGATEWAY</b>	set default gateway (default gateway value should be of format nnn.nnn.nnn.nnn) (eg. SETDEFAULTGATEWAY nnn.nnn.nnn.nnn)	string "nnn.nnn.nnn.nnn"	#*set default gateway: nnn.nnn.nnn.nnn or #*setting default gateway is failed
<b>GETDEFAULTGATEWAY</b>	get default gateway (eg. GETDEFAULTGATEWAY)	no parameter	#*the default gateway is nnn.nnn.nnn.nnn

<b>SETDNS1</b>	set DNS server 1 (DNS server value should be of format nnn.nnn.nnn.nnn) (eg. SETDNS1 nnn.nnn.nnn.nnn)	string "nnn.nnn.nnn.nnn"	<pre> #*set DNS server 1 to: nnn.nnn.nnn.nnn or #*setting DNS server 1 failed </pre>
<b>GETDNS1</b>	get DNS server 1 (eg. GETDNS1)	no parameter	<pre> #*DNS server 1 is nnn.nnn.nnn.nnn </pre>
<b>SETDNS2</b>	set DNS server 2 (DNS server value should be of format nnn.nnn.nnn.nnn) (eg. SETDNS2 nnn.nnn.nnn.nnn)	string "nnn.nnn.nnn.nnn"	<pre> #*set DNS server 2 to: nnn.nnn.nnn.nnn or #*setting DNS server 2 failed </pre>
<b>GETDNS2</b>	get DNS server 2 (eg. GETDNS2)	no parameter	<pre> #*DNS server 2 is nnn.nnn.nnn.nnn </pre>
<b>GETINTERNETSPEED</b>	get internet speed	no parameter	<pre> #*The internet speed is ... Mbps </pre>
<b>SETPROXY</b>	Sets proxy configuration	string (nnn.nnn.nnn.nnn:nnnn)	<pre> #*addr = nnn.nnn.nnn.nnn, port = nnnn </pre>
<b>GETPROXY</b>	Gets proxy configuration	no parameter	<pre> #*Current proxy is nnn.nnn.nnn.nnn:nnnn or #*No proxy address </pre>
<b>CLEARPROXY</b>	Clears proxy configuration	no parameter	<pre> #*Proxy was cleaned </pre>

#### PC COMMANDS

Command	Description	Parameter	Return
<b>SETOSDORIENTATION</b>	Set OSD orientation	string-integer n ( n = landscape, n = portrait, n = portrait2) ( landscape : 0 degree rotation, portrait : 90 degree rotation, portrat2: 270 degree rotation)	<pre> #*Wrong parameter entered (landscape, portrait, portrait2) or #*The OSD orientation set OK or #*The OSD orientation set NOK </pre>
<b>GETOSDORIENTATION</b>	Get OSD orientation	no parameter	<pre> #*The OSD orientation ... </pre>
<b>SETOPSPower</b>	Set OPS power status	string parameter "on" or "off"	<pre> #*Turning OPS on #*Turning OPS off #*The OPS is already on #*The OPS is already off #*The OPS is not enabled #*The OPS is not plugged in #*invalid value entered </pre>
<b>GETOPSPower</b>	Get OPS power status	no parameter	<pre> #*The OPS is on #*The OPS is off #*The OPS is not enabled #*The OPS is not plugged in </pre>

<b>SETOPSALWAYSON</b>	Set OPS Always on value	string parameter "true" or "false"	#*invalid value entered #*The OPS is not enabled #*OPS Always on set as true #*OPS Always on set as false
-----------------------	-------------------------	------------------------------------	--

### PICTURE COMMANDS

Command	Description	Parameter	Return
<b>SETBACKLIGHT</b>	Set backlight pin status.	str-int n (n = ON, n = OFF)	#*setBacklight port to ON or #*setBacklight port to OFF
<b>SETBACKLIGHTLEVEL</b>	Set backlight level.	int n ( $0 \leq n \leq 100$ )	#*Backlight level set to n or #*NACK
<b>GETBACKLIGHTLEVEL</b>	Get backlight level.	no parameter	#*The backlight level is ...
<b>COLOURTEMP</b>	Set colour temperature.	str-int n (n = normal, warm, cool)	#*setColourTemp() set to n
<b>GETCOLOURTEMP</b>	Get colour temperature.	no parameter	#*Colour temp is ...
<b>PICTUREMODE</b>	Select picture mode.	Display ----> int n (1 = dynamic, 2 = natural, 3 = cinema, 4 = game, 5 = sport) Signage ----> int n (1 = signage, 2 = natural, 3 = text, 4 = game, 5 = sport)	#*setPictureMode() set to n or #*Incorrect picture mode parameter entered
<b>GETPICTUREMODE</b>	Get picture mode.	no parameter	#*Picture Mode is ... for current source
<b>GETCONTRAST</b>	Get picture contrast value.	no parameter	#*THE CONTRAST VALUE : ...

<b>SETCONTRAST</b>	Set picture contrast value.	int n ( $0 \leq n \leq 100$ )	#*Picture contrast value is set to n or #*Same value is set. Do nothing. or #*Incorrect parameter entered! Value must be in the range 0-100
<b>GETBRIGHTNESS</b>	Get picture brightness value.	no parameter	#*THE BRIGHTNESS VALUE : ...
<b>SETBRIGHTNESS</b>	Set picture brightness value.	int n ( $0 \leq n \leq 100$ )	#*Picture brightness value is set to n or #*Same value is set. Do nothing. or #*Incorrect parameter entered! Value must be in the range 0-100

<b>GETSHARPNESS</b>	Get picture sharpness value.	no parameter	#*THE SHARPNESS VALUE : ...
<b>SETSHARPNESS</b>	Set picture sharpness value.	int n (0 ≤ n ≤ 100)	#*Picture brightness value is set to n or #*Same value is set. Do nothing. or #*Incorrect parameter entered! Value must be in the range 0-100
<b>PICTUREZOOM</b>	Set picture zoom mode.	str-int n (n = auto, 16:9, subtitle, 14:9, 14:9zoom, 4:3, full(only for HD channels), cinema) Customer Christie => ( n = auto shows Overscan on Display )	#*setPictureZoomMode() set to n or #*Incorrect picture zoom mode parameter entered
<b>GETPICTUREZOOM</b>	Get picture zoom mode.	no parameter	#*Picture zoommode is ...
<b>SETNOISEREDUCTION</b>	Set noise reduction.	str-int n (n = OFF, n = LOW, n = MEDIUM, n = HIGH)	#*NoiseReduction set to n or #*Missing noise reduction state
<b>GETNOISEREDUCTION</b>	Get noise reduction.	no parameter	#*NoiseReduction is ...
<b>BRIGHTNESSUP</b>	Increase Brightness Level by 1 step	no parameter	Picture brightness value is set to ... or Picture brightness value is at max value. You can not increase brightness level further.
<b>BRIGHTNESSDOWN</b>	Decrease Brightness Level by 1 step	no parameter	Picture brightness value is set to ... or Picture brightness value is at min value. You can not decrease brightness level further.
<b>CONTRASTUP</b>	Increase Contrast Level by 1 step	no parameter	Picture contrast value is set to ... or Picture contrast value is at max value. You can not increase contrast level further.
<b>CONTRASTDOWN</b>	Decrease Contrast Level by 1 step	no parameter	Picture contrast value is set to ... or Picture contrast value is at min value. You can not decrease contrast level further.

<b>SETMICRODIMMING</b>	Set micro dimming	str-int n (n = OFF, n = LOW, n = MEDIUM, n = HIGH)	#* Set Micro Dimming Level n or #*Invalid parameter. Set Micro Dimming Level (OFF, LOW, MEDIUM, HIGH)
<b>GETMICRODIMMING</b>	Get micro dimming	no parameter	#*Micro Dimming Level ...
<b>SETCOLOURSHIFT</b>	Set colour shift.	int n (-50 <= n <= 50)	#*Colour shift is set to n or #* Same value is set. Do nothing. #*Incorrect parameter entered ! Value must be between defined ranges
<b>GETCOLOURSHIFT</b>	Get colour shift.	no parameter	#*Colour shift is ...
<b>SETWB</b>	Set white balance value.	str-int type, value (type = redgain, greengain, bluegain, redoffset, greenoffset, blueoffset) (0 ≤ value ≤250)	#*White Balance is set to value or Invalid value for White Balance (0-255) or Invalid type for White Balance
<b>INCWB</b>	Increment white balance value by n.	str-int type n (type = redgain, greengain, bluegain, redoffset, greenoffset, blueoffset) (0 ≤ n ≤250)	#*White Balance is set to ... or Invalid value for White Balance (0-255) or Invalid type for White Balance
<b>DECWB</b>	Decrement white balance value by n.	str-int type n (type = redgain, greengain, bluegain, redoffset, greenoffset, blueoffset) (0 ≤ n ≤250)	#*White Balance is set to ... or Invalid value for White Balance (0-255) or Invalid type for White Balance
<b>GETWB</b>	Get white balance value.	str-int type (type = redgain, greengain, bluegain, redoffset, greenoffset, blueoffset)	#* type ...
<b>HDR</b>	Set HDR Mode	str-int n (n = ON, n = OFF)	HDR mode is n or Invalid parameter...
<b>SETDYNAMIC CONTRAST</b>	Set dynamic contrast.	str-int n (n = OFF, n = LOW, n = MEDIUM, n = HIGH)	#*Dynamic contrast value is set to n or #*Invalid parameter. Set Dynamic Contrast value (OFF, LOW, MEDIUM, HIGH)

<b>GETDYNAMIC CONTRAST</b>	Get dynamic contrast.	no parameter	#*Dynamic contrast is ...
<b>SETGAMMAPOWER</b>	Set gamma power	int n (limits not clarified)	Gamma Power Mode is set to n
<b>GETGAMMAPOWER</b>	Get gamma power	no parameter	Gamma Power Mode is ...
<b>SETGAMUTMODE</b>	Set gamut mode	int n (limits not clarified)	Gamut Color Mode is set to n
<b>GETGAMUTMODE</b>	Get gamut mode	no parameter	Gamut Color Mode is ...

#### BROWSER COMMANDS

Command	Description	Parameter	Return
<b>OPENURL</b>	Starts the given URL and returns web page load status directly.	string-integer n <load url='n' />	#*status= ... url=n
<b>GETURL</b>	Gets URL of the current page if the portal is active.	no parameter	#*URL : ...
<b>SETSETTINGSURL</b>	Sets the browser settings URL (URL set by the command is opened with long press on CMS key)	string	#*Setting URL is set
<b>GETSETTINGSURL</b>	Gets the browser settings URL	no parameter	#*Setting URL is ...
<b>SETSTARTURL</b>	Sets the start URL	string	#*Start URL is set
<b>GETSTARTURL</b>	Gets the start URL	no parameter	#*Start URL is ...
<b>GETUSERAGENT</b>	Gets portal user agent.	no parameter	#*Current UA : ...

<b>CLEARCACHE</b>	Clear browser cache/ cookies (Private datas like web form)	no parameter	#*Browser cookies are cleared
<b>CLEARBROWSERDATA</b>	Clear browser data files like History, Bookmarks, Speed Dial and Configuration	no parameter	#*Browser data files are cleared
<b>GETCMSSTATUS</b>	Gets the CMS status	no parameter	#*Do cms status assignment with SETCMSSTATUS command or Returns the value of cms status
<b>SETCMSSTATUS</b>	Sets the CMS status	string parameter max. length of 255 characters	#*CMS status set to ... or #*NACK
<b>GETCMSPARAMS</b>	Gets the CMS parameters	no parameter	#*Do cms param assignment with SETCMSPARAMS command. or Returns the value of cms params



<b>SETCMSPARAMS</b>	Sets the CMS parameters	string parameter max. length of 255 characters	#*CMS params set to ... or #*NACK
<b>SETBROWSERDEBUG</b>	Sets the browser debug 4725 port	string n (n = ON, n = OFF)	browser debug 4725 port is enabled or browser debug 4725 port is disabled
<b>SETBROWSECORS</b>	Set browser cors status to enable disable web security flag	int n (n = 0,1)	#*Browser cors is enabled or #*Browser cors is disabled or #*Browser cors operation is failed *Reboot is required after the command is executed
<b>GETBROWSECORS</b>	Get browser cors status	no parameter	#*Browser cors is enabled or #*Browser cors is disabled

## Maximum Pixel Rates

Please note that connection ports and other features shown here may vary depending on the Display model.

For Ultra HD panels,

Source	Max. Resolution	Colour Space	Bits/Component	Pixel/Rate
HDMI	4K@60Hz	YCbCr4:4:4/RGB	8 bit	594MHz
OPS	4K@60Hz	YCbCr4:4:4/RGB	8 bit	594MHz
Type-C	4K@60Hz	YCbCr4:4:4/RGB	8 bit	594MHz

## Input Matrix

Please note that connection ports and other features shown here may vary depending on the Display model.

Timing		fH (kHz)	fV (Hz)	Dot clock (MHz)	Input		
					HDMI	Type-C	DP
VESA	720 x 400	31.5	70.156	26.25	○	○	○
	640 x 480	31.469	59.95	25.175	○	○	○
	800 x 600	37.879	60.317	40	○	○	○
	1024 x 768	48.363	60.004	65	○	○	○
	1360 x 768	47.712	60.015	85.5	○	○	○
	1920 x 1080	67.5	60	148.5	○	○	○
ED	853x480p	31.5	60	27.03	○	○	○
	1024x576p	31.25	50	27	○	○	○
HD	1280x720p	37.5	50	74.25	○	○	○
		44.995	59.94	74.176	○	○	○
		45	60	74.25	○	○	○
	1920x1080i	28.13	50	74.25	○	○	○
		33.716	59.94	74.175	○	○	○
		33.75	60	74.25	○	○	○
	1920x1080p	56.25	50	148.5	○	○	○
		67.432	59.95	148.35	○	○	○
		67.5	60	148.5	○	○	○
UHD (Only for 4K models)	3840x2160p	67.5	30	297	○	○	○
	3840x2160p	135	60	594	○	○	○

## Supported Media Formats from USB

### Video Decoder

Codec	Verified Max. Performance	Audio Codec	Container
MPEG-1	1920x1080P @ 60fps	AC3	DAT, MPEG, MPG, TS
MPEG-2	1920x1080P @ 60fps	MP3, PCM	MPEG, MPG, M2V, TS, TP, VOB

Codec	Verified Max. Performance	Audio Codec	Container
MPEG-4 ASP	1920x1080p @ 60fps	MP3, AC-3, AAC, PCM, ADPCM	AVI, MP4, MOV, 3GP
MJPEG	1920x1080p @ 30fps	MP3, U-LAW	AVI
XviD	1920x1080p @ 30fps	AC3, MP3	AVI, OGM
H.263	720x576p @ 30fps	MP3, AC-3, AAC, AMR-NB	3GP, 3G2, MOV, MP4
H.264	3840x2160 @ 30fps 100Mbps	AAC, AAC-LC, MP3, AC3, PCM, Vorbis, AMR-NB	AVI, MOV, MP4, MKV, TS, M2TS, MTS, M4V, FLV, F4V, PMP
H.265 Main 10	7680x4320 @ 24fps 80Mbps, 3840x2160 @ 60fps 80Mbps	AAC, AC3	TS, MP4, MKV
VC-1	1920x1080p @ 25fps	AC3, PCM, DTS	M2TS, MPEG
WMV3	1280x720p @ 30fps	AC3	ASF, MKV
AVS-P16	1920x1080p @ 30fps	-	-
AVS-P2 Jizhun	720x576p @ 30fps	-	TS
AVS2	3840x2160p @ 60fps	-	TS
VP9 Profile-2	7680x4320 @ 24fps VP9 67Mbps, 4096x2304p @ 60fps VP9 Profile-2 60Mbps	Vorbis	.webm/.vp9/.ivf
VP8	1920x1080p @ 30fps	Vorbis	.webm/.mkv
AV1	3840x2160p @ 60fps 14.6Mbps	AAC, PCM, AC3	MP4, TS

## Video Encoder

Codec	Verified Max. Performance	Audio Codec	Container
H.264	1920x1080p @ 30fps	AAC	-

## Image Decoder

Codec	Resolution	Container
JPEG baseline/Progress	No restriction	JPG, JPEG
BMP	No restriction	BMP
GIF	No restriction	JPG, JPEG

Codec	Resolution	Container
PNG	No restriction	PNG

## Image Encoder

Software image encoder supported.

## Audio Decoder

Codec	Channel	Bit Rate	Sample rate	Container
MPEG 1/2/2.5, Audio Layer 3	2	8 ~ 320 kbps, CBR and VBR	8 ~ 48 kHz	MP2/MP3
PCM, IMA-ADPCM, MS-ADPCM, U-Law	5,1	Up to 1.5Mbps	8 ~ 48 kHz	WAV
Vorbis	5,1	-	8 ~ 96 kHz	OGG
Flac	5,1	VBR	8 ~ 96 kHz	FLAC
APE	2	VBR	8 ~ 48 kHz	Ape
AAC-LC, AAC-HE(AAC+)	5,1	VBR	8 ~ 96 kHz	AAC/M4A
PCM/A-LAW	5,1	-	8 ~ 48 kHz	AIF/AIFF/ALAW
ALAC	2	VBR	8 ~ 48 kHz	alac
WMA Version 7, 8, 9	5,1	8 ~ 320 kbps, CBR and VBR	8 ~ 96 kHz	WMA

## Audio Encoder

Software audio encoder supported.

## Movie Subtitle

Format	Container
SAMI	SMI
Advanced Substation Alpha	ASS / SSA
SubRip	SRT
DVD	SUB
Blue Ray	PGS
Timed text	SBTL
Aqtitle	AQT
Lyric	LRC
MircoDVD	SUB
Mplayer1/2	MPL
Mpsub	SUB

Format	Container
Phoenix Japanimation Society	PJS
subviewer1.0/2.0	SUB
Text	TXT
Vplayer	TXT

<b>Format</b>	<b>Container</b>
Extensible Markup Language	XML
DVB-SUB	DVB
Jacosub	JS

## System Features

### Panel

Panel type	75" (189cm) 16/7 DLED	
Resolution	3840x2160 (16:9) -UHD	
Visual angle	Horizontal	89°
	Perpendicular	89°
Max. brightness	Typ: 400 cd/m2	
H-Frequency	60 KHz	
V-Frequency	67,5 KHz	

### Audio

2 x 20 W Audio Output Power

### Network Connection

1 x Ethernet (LAN) for Internet connectivity

802.11 a/b/g/n/ac built in WLAN support

### Input/Output Ports

**(May vary depending on model)**

1 x RS232 port (3,5 mm)

1 x Ethernet In port

1 x USB Type-C port

2 x USB Type-B port (for touch only)

1 x USB 2.0 port (for touch only)

2 x USB 3.0 port (5VDC max900mA)

3 x HDMI 2.0 In port

1 x Headphone/Line Out port

1 x HDMI Out port

1 x SPDIF Optical Out port

1 x RJ12 port (for sensor)

1 x RJ12 port (for service use only)

### OPS

Up to 40W

### Power

110-240V AC 50-60Hz 320W

### Weight (kg)

59

### Display Dimensions DxLxH (mm)

1714mm x 1002mm x 87mm

## Wireless LAN Transmitter Specifications

Frequency Ranges	Max Output Power
2400 - 2483,5 MHz (CH1 - CH13)	< 100 mW
5150 - 5250 MHz (CH36 - CH48)	< 200 mW (*)
5250 - 5350 MHz (CH52 - CH64)	< 200 mW (*)
5470 - 5725 MHz (CH100 - CH140)	< 200 mW (*)

(\*) '< 100 mW' for the Ukraine

### Country Restrictions

The Wireless LAN equipment is intended for home and office use in all EU countries, the UK and Northern Ireland (and other countries following the relevant EU and/or UK directive). The 5.15 - 5.35 GHz band is restricted to indoor operations only in the EU countries, in the UK and Northern Ireland (and other countries following the relevant EU and/or UK directive). Public use is subject to general authorisation by the respective service provider.

Country	Restriction
Russian Federation	Indoor use only

The requirements for any country may change at any time. It's recommended that user checks with local authorities for the current status of their national regulations for both 2.4 GHz and 5 GHz wireless LAN's.

### Warning

Surges could cause data loss except monitoring modes.

**Note:** Some of the system features including software functions and available ports are optional and dependent on the model options that you have requested.

This document contains all available options for informing purposes.

## Accessories Included

- Remote Control
- Batteries: 2 x AAA
- Instruction Book
- Quick Start Guide

## Information for Users on Disposal of Old Equipment and Batteries

### [European Union only]

Equipment bearing these symbols should not be disposed as general household waste.

You should look for appropriate recycling facilities and systems for the disposal of these products.

**Note:** The sign Pb below the symbol for batteries indicates that this battery contains lead.

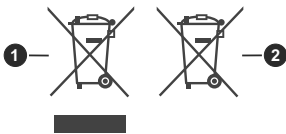

① Products

② Battery

## Licence Notification

The terms HDMI, HDMI High-Definition Multimedia Interface, HDMI trade dress and the HDMI Logos are trademarks or registered trademarks of HDMI Licensing Administrator, Inc.



Manufactured under licence from Dolby Laboratories. Dolby, Dolby Audio, and the double-D symbol are trademarks of Dolby Laboratories Licensing Corporation.

The Bluetooth® word mark and logos are registered trademarks owned by the Bluetooth SIG, Inc. and any use of such marks by Vestel Elektronik Sanayi ve Ticaret A.S. is under license. Other trademarks and trade names are those of their respective owners.

This product is protected by certain intellectual property rights of Microsoft Corporation. Use or distribution of such technology outside of this product is prohibited without a licence from Microsoft or an authorised Microsoft subsidiary.

## Vesa Wall Mount Measurements

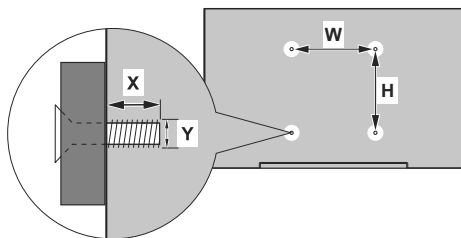

<b>Hole Pattern Sizes (mm)</b>	<b>W</b>	<b>H</b>
	<b>800</b>	<b>600</b>
<b>Screw Sizes</b>		
<b>Length (X)</b>	min. (mm)	<b>6</b>
	max. (mm)	<b>9</b>
<b>Thread (Y)</b>	<b>M8</b>	



## Installation On An Indented Wall

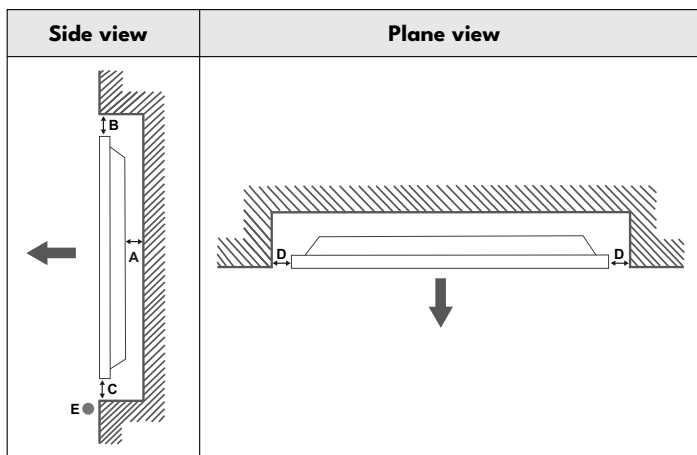

- A** Minimum 50 mm
- B** Minimum 70 mm
- C** Minimum 50 mm
- D** Minimum 50 mm
- E** Ambient temperature range: 0-35°C



When installing the product on an indented wall, allow at least the space specified above between the product and wall for ventilation and ensure that the ambient temperature is kept between 0°C-35°C. Do not expose the product to direct sunlight.

We will take no responsibility for any damages or failures in case our products are not being used subject to these recommendations and/or instructions for use.

- TR: İşbu belgede; VESTEL Elektronik Sanayi ve Ticaret A.Ş., telsiz ekipmanı tipi MONITOR'nin 2014/53/AB sayılı direktife uygun olduğunu beyan eder. AB uyumluk beyanının tam metni internet adresinde mevcuttur: doc.vosshub.com
- EN: Hereby, VESTEL Elektronik Sanayi ve Ticaret A.Ş., declares that the radio equipment type MONITOR is in compliance with Directive 2014/53/EU. The full text of the EU declaration of conformity is available at the following internet address: doc.vosshub.com
- BG: С настоящото VESTEL Elektronik Sanayi ve Ticaret A.Ş., декларира, че този тип радиосъоръжение MONITOR е в съответствие с Директива 2014/53/ЕС. Цялостният текст на ЕС декларацията за съответствие може да се намери на следния интернет адрес: doc.vosshub.com
- CS: Tímto VESTEL Elektronik Sanayi ve Ticaret A.Ş., prohlašuje, že typ rádiového zařízení MONITOR je v souladu se směrnicí 2014/53/EU. Úplné znění EU prohlášení o shodě je k dispozici na této internetové adrese: doc.vosshub.com
- DA: Hermed erklærer VESTEL Elektronik Sanayi ve Ticaret A.Ş., at radioudstyrstypen MONITOR er i overensstemmelse med direktiv 2014/53/EU. EU-overensstemmelseserklæringens fulde tekst kan findes på følgende internetadresse: doc.vosshub.com
- DE: Hiermit erklart VESTEL Elektronik Sanayi ve Ticaret A.Ş., dass der Funkanlagentyp MONITOR der Richtlinie 2014/53/EU entspricht. Der vollständige Text der EU-Konformitätserklärung ist unter der folgenden Internetadresse verfügbar: doc.vosshub.com
- EL: Με την παρούσα ο/η VESTEL Elektronik Sanayi ve Ticaret A.Ş., δηλώνει ότι ο ραδιοεξοπλισμός MONITOR πληροί την οδηγία 2014/53/ΕΕ. Το πλήρες κείμενο της δήλωσης συμμόρφωσης ΕΕ διατίθεται στην ακόλουθη ιστοσελίδα στο διαδίκτυο: doc.vosshub.com
- ES: Por la presente, VESTEL Elektronik Sanayi ve Ticaret A.Ş., declara que el tipo de equipo radioeléctrico MONITOR es conforme con la Directiva 2014/53/UE. El texto completo de la declaración UE de conformidad está disponible en la dirección Internet siguiente: doc.vosshub.com
- ET: Käesolevaga deklareerib VESTEL Elektronik Sanayi ve Ticaret A.Ş., et käesolev raadioseadme tüüp MONITOR vastab direktiivi 2014/53/EL nõuetele. Eli vastavusdeklaratsiooni täielik tekst on kättesaadav järgmisel internetiaadressil: doc.vosshub.com
- FI: VESTEL Elektronik Sanayi ve Ticaret A.Ş., vakuuttaa, että radioalaitetyyppi MONITOR on direktiivin 2014/53/EU mukai-nen. EU-vaatimustenmukaisuusvakuutuksen täysimittainen teksti on saatavilla seuraavassa internetosoitteissa: doc.vosshub.com
- FR: Le soussigné, VESTEL Elektronik Sanayi ve Ticaret A.Ş., déclare que l'équipement radioélectrique du type MONITOR est conforme à la directive 2014/53/UE. Le texte complet de la déclaration UE de conformité est disponible à l'adresse internet suivante: doc.vosshub.com
- HR: VESTEL Elektronik Sanayi ve Ticaret A.Ş., ovime izjavljuje da je radijska oprema tipa MONITOR u skladu s Direktivom 2014/53/EU. Cjeloviti tekst EU izjave o sukladnosti dostupan je na sljedećoj internetskoj adresi: doc.vosshub.com
- HU: VESTEL Elektronik Sanayi ve Ticaret A.Ş., igazolja, hogy a MONITOR típusú rádióberendezés megfelel a 2014/53/EU irányelvnek. Az EU-megfelelőségi nyilatkozat teljes szövege elérhető a következő internetes címen: doc.vosshub.com
- IT: Il fabbricante, VESTEL Elektronik Sanayi ve Ticaret A.Ş., dichiara che il tipo di apparecchiatura radio MONITOR è conforme alla direttiva 2014/53/UE. Il testo completo della dichiarazione di conformità UE è disponibile al seguente indirizzo Internet: doc.vosshub.com
- LT: Aš, VESTEL Elektronik Sanayi ve Ticaret A.Ş., paMONITORirtinu, kad radio įrenginių tipas MONITOR atitinka Direktyvą 2014/53/ES. Visas ES atitikties deklaracijos tekstas prieinamas šiuo interneto adresu: doc.vosshub.com
- LV: Ar šo VESTEL Elektronik Sanayi ve Ticaret A.Ş., deklarē, ka radioiekārtā MONITOR atbilst Direktīvai 2014/53/ES. Pilns ES atbilstības deklarācijas teksts ir pieejams šādā interneta vietnē: doc.vosshub.com
- MT: B'dan, VESTEL Elektronik Sanayi ve Ticaret A.Ş., niddikjara li dan it-tip ta' taghmir tar-radju MONITOR huwa konformi mad-Direttiva 2014/53/UE. It-test kollu tad-dikjarazzjoni ta' konformità tal-UE huwa disponibbli f'dan l-indirizz tal-Internet li ġej: doc.vosshub.com
- NL: Hierbij verklaar ik, VESTEL Elektronik Sanayi ve Ticaret A.Ş., dat het type radioapparatuur MONITOR conform is met Richtlijn 2014/53/UE. De volledige tekst van de EU-conformiteitsverklaring kan worden geraadpleegd op het volgende internetadres: doc.vosshub.com
- PL: VESTEL Elektronik Sanayi ve Ticaret A.Ş., niniejszym oświadczam, że typ urządzenia radiowego MONITOR jest zgodny z dyrektywą 2014/53/UE. Pełny tekst deklaracji zgodności UE jest dostępny pod następującym adresem internetowym: doc.vosshub.com
- PT: O(a) abaixo assinado(a) VESTEL Elektronik Sanayi ve Ticaret A.Ş., declara que o presente tipo de equipamento de rádio MONITOR está em conformidade com a Diretiva 2014/53/UE. O texto integral da declaração de conformidade está disponível no seguinte endereço de Internet: doc.vosshub.com
- RO: Prin prezenta, VESTEL Elektronik Sanayi ve Ticaret A.Ş., declară că tipul de echipamente radio MONITOR este în conformitate cu Directiva 2014/53/UE. Textul integral al declarației UE de conformitate este disponibil la următoarea adresă internet: doc.vosshub.com
- SK: VESTEL Elektronik Sanayi ve Ticaret A.Ş., týmto vyhlasuje, že rádiové zariadenie typu MONITOR je v súlade so smernicou 2014/53/UE. Úplné EÚ vyhlásenie o zhode je k dispozícii na tejto internetovej adrese: doc.vosshub.com
- SL: VESTEL Elektronik Sanayi ve Ticaret A.Ş., potrjuje, da je tip radijske opreme MONITOR skladen z Direktivo 2014/53/EU. Celotno besedilo izjave EU o skladnosti je na voljo na naslednjem spletnem naslovu: doc.vosshub.com
- SV: Härmed försäkrar VESTEL Elektronik Sanayi ve Ticaret A.Ş., att denna typ av radioutrustning MONITOR överensstämmer med direktiv 2014/53/EU. Den fullständiga texten till EU-försäkran om överensstämmelse finns på följande webbadress: doc.vosshub.com
- RU: Настоящим компания VESTEL Elektronik Sanayi ve Ticaret A.S. заявляет, что радиоборудование типа ЖК ДИСПЛЕЙ соответствует Директиве 2014/53/ЕU. Полный текст декларации соответствия ЕС доступен по следующему адресу в Интернете address: doc.vosshub.com



**Vestel Trade Co.**

Organize Sanayi Bölgesi, 45030 Manisa/Türkiye  
**Phone:** 90 - 236 233 25 82  
**Fax:** 90 - 236 233 25 84  
vesteltrade@vestel.com.tr  
www.vestel.com.tr

**Vestel France S.A.**

17 Rue de la Couture-Silic BP 10190-94563 RUNGIS  
Cedex/France  
**Phone:** 33 - 1 46 75 00 29  
**Fax:** 33 - 1 41 80 99 31  
vestel@vestel-france.fr

**Vestel Holland B.V. Germany Branch Office**

Parking 6 D-85748 Garching  
**Phone:** 49 - 89 55295 - 0  
**Fax :** 49 - 89 55295 - 2000  
info@vestel-germany.de  
www.vestel-germany.de

**Vestel Iberia**

Avda,Partenon,16-18 Planta 1 Oficina 6, 28042 Madrid/  
**SpainPhone:** 34-91 320 63 98  
**Fax:** 34-91 320 52 58  
vestel@vestel.es www.vestel.es

**Gruppo Industriale Vesit S.P.A**

Società Unipersonale Via Polidoro da Caravaggio,  
6 20156 Milano (MI)  
**Phone:**+39 02 842 48577  
**Fax:** +39 02 842 48617  
info@givesit.it www.givesit.it

**Vestel UK Ltd**

Vestel House, Waterside Drive  
Langley, Berkshire SL3 6EZ  
**Phone:** 44 3330 146 400  
info@vestel-uk.com  
www.vestel.co.uk

**Vestel Benelux B.V.**

P.O. Box 29179 3001 GD - Rotterdam / Netherlands  
**Phone:** 31 - 10 235 1000  
**Fax:** 31 - 10 235 1003  
info@vestelbenelux.nl  
www.vestelbenelux.nl

**Vestel Scandinavia**

Postikatu 4, FI-04400 Järvenpää / Finland  
**Phone:** +358 46 712 2262  
**Fax:** +358 (0) 9 251 7 8222

**Vestel CIS Ltd.**

1-st Graivoronovsky Proezd, No.20 Building 16, 109518,  
Moscow /Russia  
**Phone:**7 - 095 956 8230  
**Fax:** 7 - 095 956 8233  
info@vestel.ru

**Vestel Electronica**

Str Zidarului nr 9-11, Sector 5 Bucuresti, ZIP 051765  
Bucharest/Romania  
**Phone:** 40- 31 425 42 93  
**Fax:** 40-31 425 42 95  
www.vestel.ru Office@vestel.ro www.vestel.co



50705738

