

AXIS M5526-E PTZ Camera

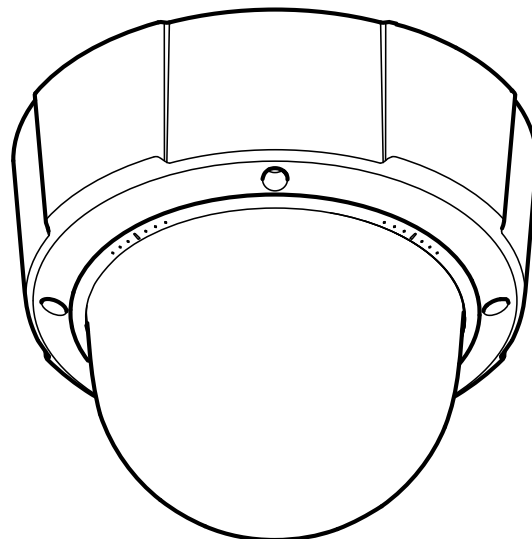

Repainting instructions

AXIS M5526-E PTZ Camera

Impact on warranty

Impact on warranty

This product is approved for repaint by Axis, provided that you follow the instructions in this document and at axis.com/warranty-implication-when-repainting.

Risks with repainting

There are several risks when disassembling or assembling an Axis product. There is always a certain yield loss during assembly. Training of operators and the use of correct tools mediates some of the problems but they can never be fully avoided. Some of the risks include:

ESD Damage – Always handle the product in an ESD safe environment. Even if precautions are taken there is always a risk of ESD damage. The damage can remain undetected and cause problems during the lifetime of the equipment.

Dust contamination – Opening a camera may expose the lens and sensor to dust or paint. Dust will affect the optical performance. Lenses need to be disassembled in a dust-free environment, preferably a cleanroom.

Paint overspray – Masking the different components of the equipment is critical. Failure to mask sensitive areas can cause problems with assembling the equipment. Any areas that are not painted at factory or have a different surface treatment than the rest of the parts (threads, ground and electrical contact surfaces) must also be masked to ensure function.

AXIS M5526-E PTZ Camera

Repaint the product

Repaint the product

Preparations

- If applicable, disassemble the device according to the instructions in this document.
- Clean all parts that will be repainted thoroughly to remove grease, dust, or oil.
- To ensure reassembly and functionality of the product, mask any openings (for example for screws, LED indicators, or microphones) before you paint.

Pretreatment of parts

Depending on the part material and type of coating applied at factory, pretreatment might be necessary for the new coating to adhere well. Before you apply a new coating, we recommend the following pretreatment:

1. If necessary, roughen up the surface with a light sandpaper or similar to increase adhesion. Alternatively, remove the original coating down to base material.
2. Clean the parts properly to remove oil, grease, and dust.
3. If necessary, apply a primer layer suitable for the specific material to increase adhesion to the parts. For outdoor products, we recommend a primer to improve corrosion resistance.

We recommend pretreatment of parts made of the following materials:

- powder coated
- wet painted
- anodised
- chromated
- stainless steel
- other metal
- plastic

The materials used in the product are PC Panlite LN-3520ZH and PA+GF Grivory GVX-5H (GF50).

AXIS M5526-E PTZ Camera

Repaint the product

Disassembly

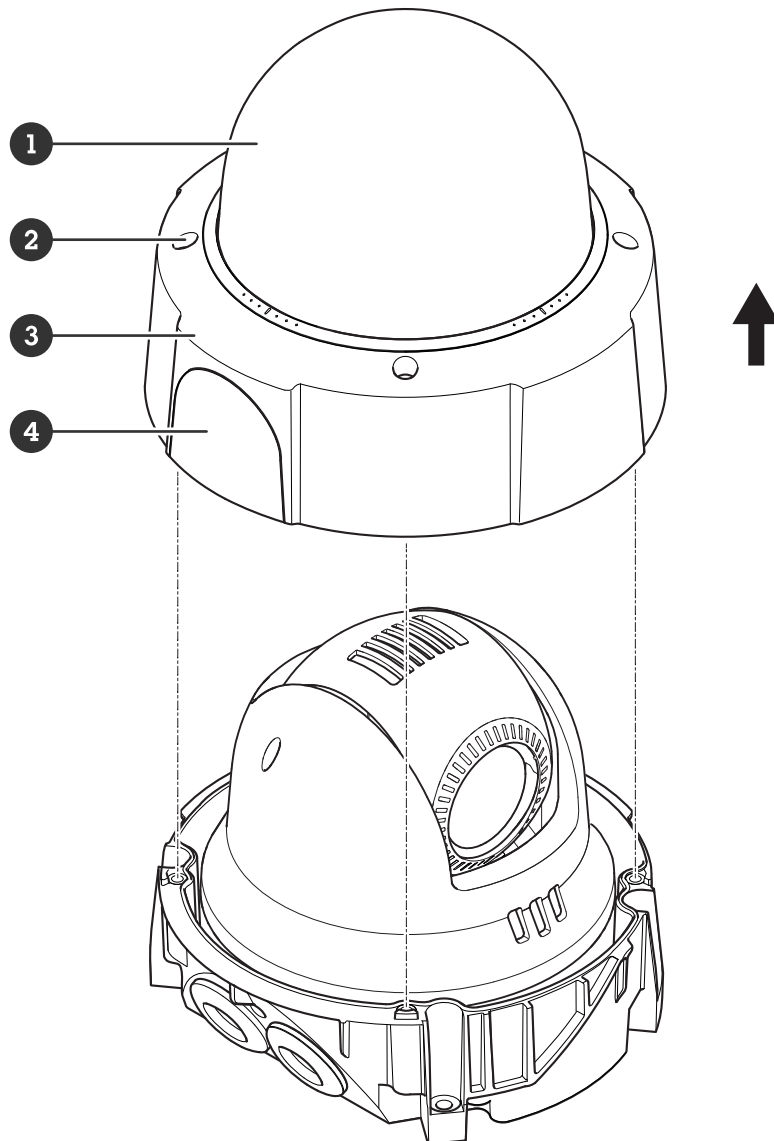

- 1 Dome
- 2 Screws (4x, T20)
- 3 Dome cover
- 4 Conduit cover

1. Remove the dome cover from the camera unit.
2. Remove the conduit cover if you are not going to use it.

AXIS M5526-E PTZ Camera

Repaint the product

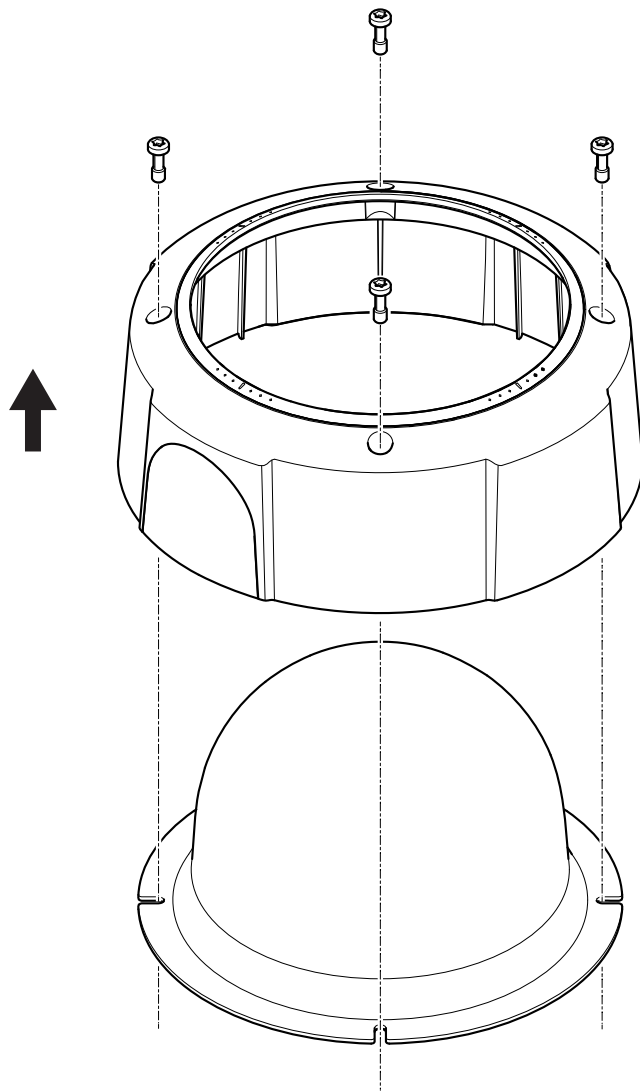

3. Remove the dome from the dome cover (4 screws, T20).
4. Remove the screws from the dome cover.

AXIS M5526-E PTZ Camera

Repaint the product

Repainting

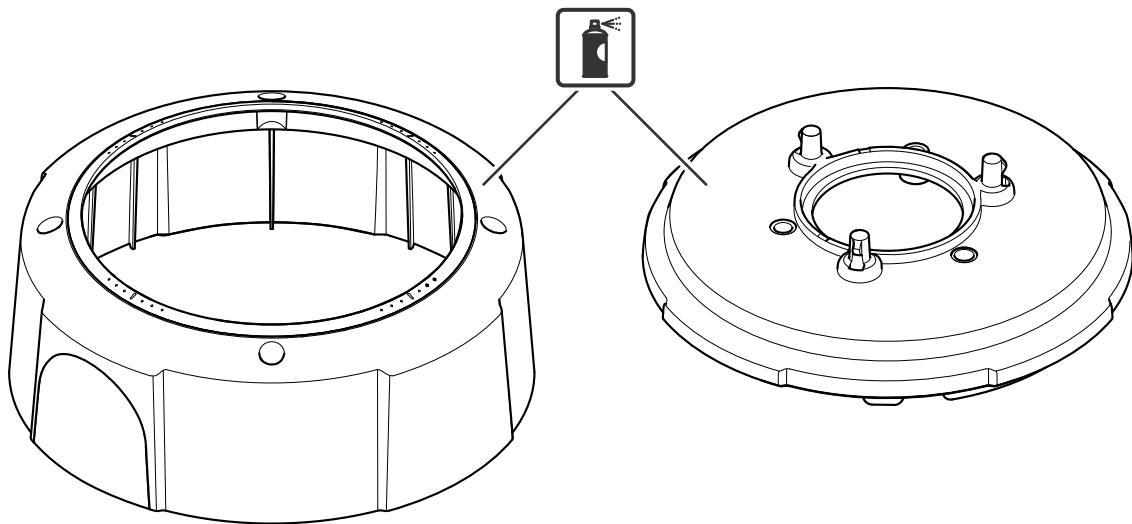

1. Make sure all necessary preparations have been made, see *Preparations on page 3*.
2. Apply a thin and even layer of spray paint according to the instructions of the paint manufacturer.
3. Let the paint dry.
4. To get a better coverage and clearer color, apply a second layer of spray paint.
5. When the paint is dry, remove the masking and reassemble the product.

Reassembly

1. Reattach the dome to the dome cover.
2. Reattach the dome cover to the camera unit and tighten the screws (torque 0.5 Nm, 0.37 lb ft).

