

# **Performance 1 Silent**

**MANUAL**



**[www.antec.com/support](http://www.antec.com/support)**

US & Canada

**[support@antec.com](mailto:support@antec.com)**

Europe

**+31-(0)-10-462-2060**  
**[eusupport@antec.com](mailto:eusupport@antec.com)**

Asia

**+886-(0)800-060-696**  
**[apsupport@antec.com](mailto:apsupport@antec.com)**

Authorized representative in Europe: Antec Europe BV, Corkstraat 46,  
3047 AC Rotterdam / The Netherlands

**[www.Antec.com](http://www.Antec.com)**

 Antec Inc.  antec  Antec  antec  Antec\_Official





Antec, Inc. is the global leader in high-performance computer components and accessories for the gaming, PC upgrade and Do-It-Yourself markets.

Founded in 1986, Antec is recognized as a pioneer in the industry and has maintained its position as a worldwide market leader and international provider of quiet, efficient and innovative products.

Antec has also achieved great success in the distribution channel, meeting the demands of quality-conscious system builders, VARs and integrators.

---

## P.2 CONTENTS AND ACCESSORIES

Inhalt Und Zubehör | Contenu Et Accessoires | Contenuto E Accessori | Contenido Y Accesorios | 商品と配件 | 内容物與配件 | 내용을 및 부속품 | 内容と付属品

---

## P.4 PRODUCT INTRODUCTION

Produktübersicht | Introduction Au Produit | Introduzione Del Prodotto | Presentación Del Producto | 產品介紹 | 產品介紹 | 제품 소개 | 商品紹介

---

## P.10 INSTALLATION GUIDE

Installationsanleitung | Guide D'installation | Guida All'installazione | Guía De Instalación | 安裝指南 | 安裝指南 | 설치 안내 | 設置のガイド



# CONTENTS AND ACCESSORIES

## I ACCESSORY BOX CONTENTS

Packungsinhalt | Contenu de l'Emballage | Contenuto della confezione | Contenido del paquete | 配件盒内容物 | 产品 | 포장 내용물 | パッケージの内容

### A Tool Box

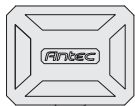

**\*1**

### B Cable Tie



**\*5**

### C Velcro Straps



**\*6**

### D 1-to-3 PWM fan splitter cable

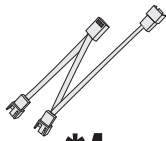

**\*1**

## Toolbox Contents

### **E** Motherboard Screws/ 2.5" SSD Screws

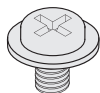

**\*28**

### **F** Power Supply Screws



**\*5**

### **G** Standoffs



**\*3**

### **H** 3.5" HDD Screws



**\*8**

### **I** Standoff Mounting Tool



**\*1**

### **J** Shroud Fan Screws

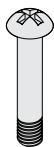

**\*12**

# PRODUCT INTRODUCTION

## 1 CASE OVERVIEW

Gehäuseübersicht | Vue d'Ensemble du Boîtier | Vista generale del contenitore | Información de la caja | 機箱概述 | 产品特点 | 케이스 개요 | 케이스概要

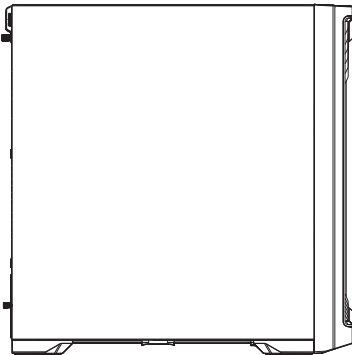
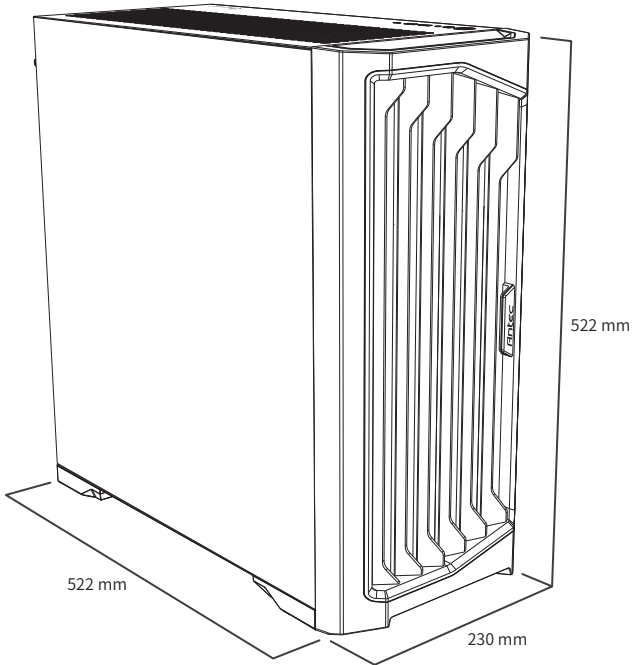

Left Side

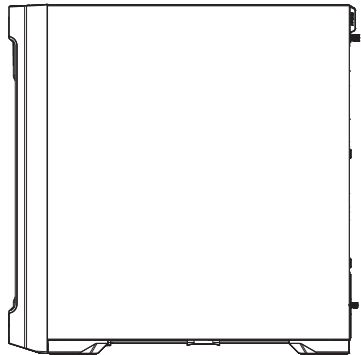

Right Side

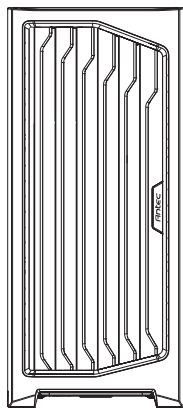

Front

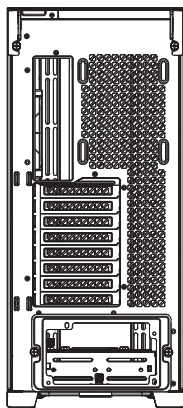

Rear

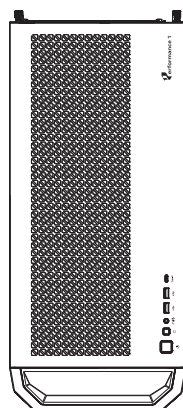

Top

## 2 I/O PANEL

Anschlüsse und Tasten | Connecteurs et Boutons | Connettori e pulsanti | Conectores y botones | I/O接口 | I/O端口 | 커넥터 및 버튼 | コネクタとボタン

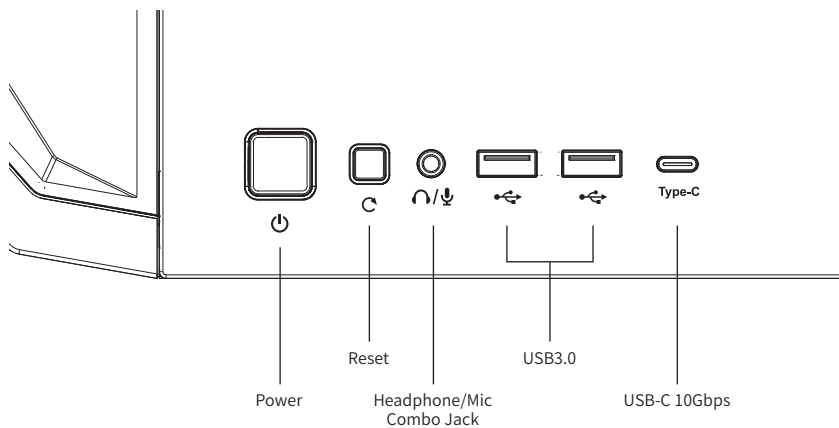

# PRODUCT INTRODUCTION

## 3 PARTS

Komponenten | Pièces | Parti | Partes | 機箱結構 | 机箱结构 | 부품 | 部品

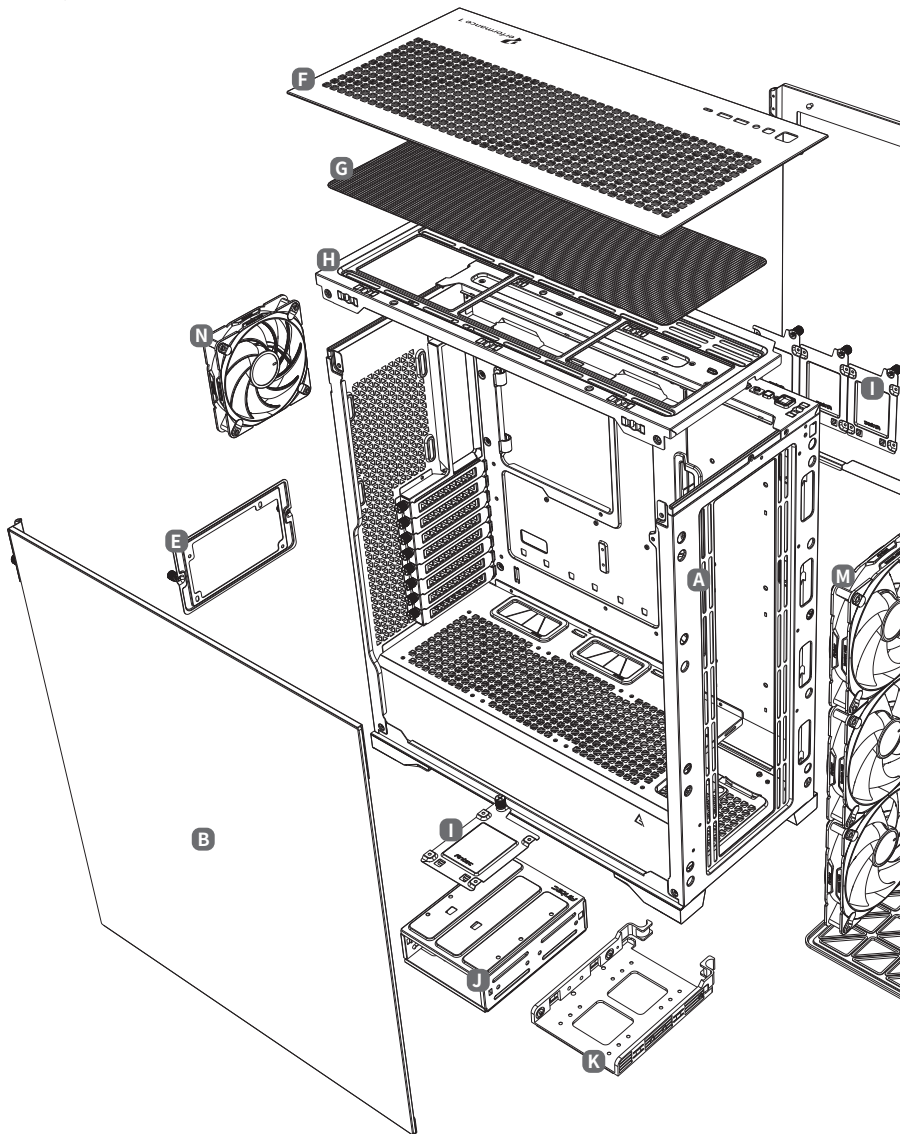

## A Case Body

Gehäuse | Corps du Boîtier | Corpo contenitore | Cuerpo de la caja | 机箱結構 | 机箱 | 케이스 본체 | 케이스 본체

## B Sound Dampening Side Panel

Schalldämpfendes Seitenteil | Panneau latéral à amortissement du son | Pannello laterale insonorizzato | Panel lateral de amortiguación de sonido | 静音側板 | 静音側板 | 방음 사이드 패널 | 노이즈를 흡수하는 흡음패널

## C Front Panel

Frontpanel | Façade | Pannello frontale | Panel Frontal | 前面板 | 前面板 | 전면 패널 | 프런트패널

## D Front Magnetic Filter

Staubfilter magnetisch | Filtre façade aimanté | Filtro magnetico frontale | Filtro Magnético Frontal | 磁吸式前濾網 | 磁吸式前濾網 | 전면 자석식 먼지 필터 | 프런트마그네틱필터

## E PSU Bracket

Netzteilhalterung | Support bloc d'alimentation | Staffa dell'alimentatore | Bracket de la PSU | 電源固定支架 | 電源固定支架 | 파워 브라켓 | PSU브라켓

## F Top Panel

Panel oben | Panneau haut | Pannello superiore | Panel de Arriba | 上面板 | 上面板 | 상단 패널 | 톱패널

## G Top Filter

Filtre oben | Filtre Haut | Filtro superiore | Filtro de Arriba | 上濾網 | 上濾網 | 상단 먼지 필터 | 톱필터

## H Removable Top Cooling Bracket

Abnehmbare obere Kühlerhalterung | Support amovible système de refroidissement haut | Staffa di raffreddamento superiore rimovibile | Bracket Extraible de Refrigeración de Arriba | 上方可拆式散熱器支架 | 上方可拆式散熱器支架 | 제거 가능 상단 쿨링 브라켓 | 着脱式의水冷브라켓

## I 2.5" SSD (Solid-State Drive) Tray

2,5-Zoll-SSD-Einschub (Solid-State Drive) | Plateau SSD 2,5" | Tray SSD da 2,5" | Bandeja de 2,5" SSD (Solid-State Drive) | 2.5吋SSD 硬碟架 | 2.5吋SSD 硬碟架 | 2.5 인치 SSD 트레이 | 2.5" SSD트레이

## J 3.5" HDD (Hard Disk Drive) Tray

3,5-Zoll-HDD-Fach (Festplattenlaufwerk) | Plateau HDD 3,5" | Tray HDD da 3,5" | Bandeja de 3,5" HDD (Hard Disk Drive) | 3.5吋HDD 硬碟架 | 3.5吋HDD 硬碟架 | 3.5 인치 HDD 트레이 | 3.5" HDD트레이

## K HDD / SSD Tray

HDD / SSD-Fach | Plateau HDD / SSD | HDD / SSD Tray | Bandeja HDD/SSD | HDD/SSD 硬碟架 | 复合式 硬盘架 | HDD / SSD 트레이 | HDD / SSD트레이

## L Bottom Dust Filter

Unterer Staubfilter | Filtre à poussière du bas | Filtro antipolvere inferiore | Filtro de Polvo de Abajo | 底部濾網 | 底部濾網 | 하단 먼지 필터 | 포트뮴필터

## M Tranquil 140mm PWM Silent Fan

Tranquil 140mm Lüfter | Ventilateur Tranquil 140mm | Ventola Tranquil 140mm | Ventilador Tranquil 140mm | Tranquil 140mm 風扇 | Tranquil 140mm 風扇 | Tranquil 140mm 팬 | Tranquil 140mm 팬

## N Tranquil 120mm PWM Silent Fan

Tranquil 120mm Lüfter | Ventilateur Tranquil 120mm | Ventola Tranquil 120mm | Ventilador Tranquil 120mm | Tranquil 120mm 風扇 | Tranquil 120mm 風扇 | Tranquil 120mm 팬 | Tranquil 120mm 팬

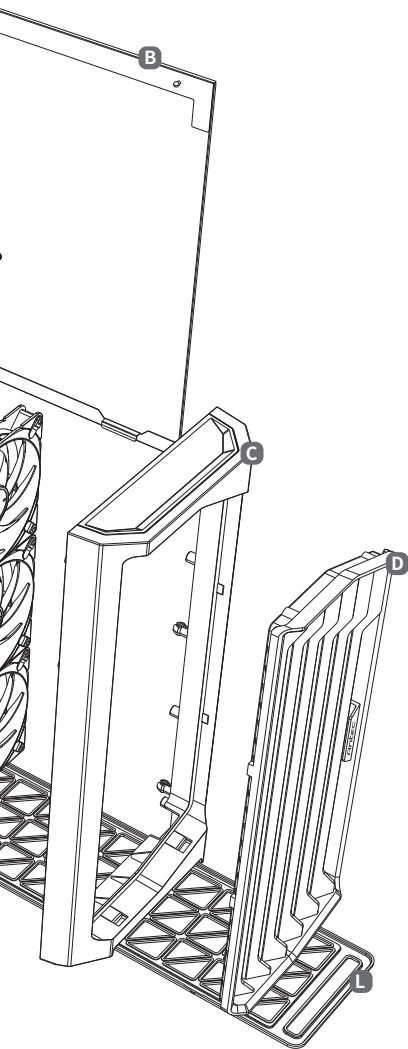

# PRODUCT INTRODUCTION

## 4 CASE SPECIFICATIONS

Gehäusespezifikationen | Caractéristiques du Boitier | Specifiche del contenitore | Especificaciones de la caja | 机箱規格 | 机箱规格 | 케이스 사양 | 케이스仕様

### General

Form Factor	Full Tower
Material(s)	Steel + Plastic
Side Panel Type	Sound Dampening Side Panel (Both Sides)
Access & Controls	Power, Reset , USB 3.0 x 2, Type-C 10Gbps x 1, Headphone/Mic Combo Jack
Dimensions	522 x 230 x 522 mm (DWH)

### Compatibility & Clearances

Mainboard Support	E-ATX, ATX, Micro-ATX, ITX
Max PSU Length(Include cable)	≤ 245mm (with HDD) / ≤ 440mm (without HDD)
Max CPU Cooler Height	≤ 175mm
Max GPU Length	≤ 400mm
Radiator (Front)	120/140/240/280/360/420mm
Radiator (Top)	120/140/240/280/360mm
Radiator (Rear)	120mm

### Expansion Slots & Drive Bays

Expansion Slots	8
3.5" / 2.5"	2 / 2
2.5"	3

### Cooling

Front	3 x 120mm / 3 X 140mm
Top	3 x 120mm / 3 x 140mm
Rear	1 x 120mm
Power Supply Shroud	3 x 120mm
Included Fan(s)	3 x 140mm PWM Silent fans in front + 1 x 120mm PWM Silent fan in rear
Dust Filter	Front / Top / Bottom

## 5 FAN SPECIFICATIONS

Lüfterspezifikationen | Spécifications ventilateur | Specifiche della ventola | Especificaciones Del Ventilador | 風扇規格 | 風扇規格 | 팬 상세 스펙 | ファンの仕様

### [A] Tranquil 140mm PWM Silent Fan

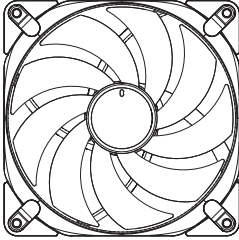

Fan Type :	PWM Fan
Fan Speed :	450 RPM ~ 1500 RPM
Rated Voltage :	DC 12 V
Operating Voltage :	DC 7.0 ~ 13.8 V
Rated Current :	≤0.18 A

### [B] Tranquil 120mm PWM Silent Fan

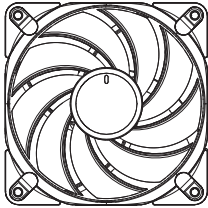

Fan Type :	PWM Fan
Fan Speed :	400 RPM ~ 2000 RPM
Rated Voltage :	DC 12 V
Operating Voltage :	DC 7.0 ~ 13.8 V
Rated Current :	≤0.20 A



# INSTALLATION GUIDE

## 1 REMOVE SIDE PANEL

Seitenwand abnehmen | Retirer les Panneaux Latéraux | Rimozione del pannello laterale | Extracción de panel lateral | 拆除側面板 | 拆除側板 | 측면 패널 제거 | 側面のパネルを外す

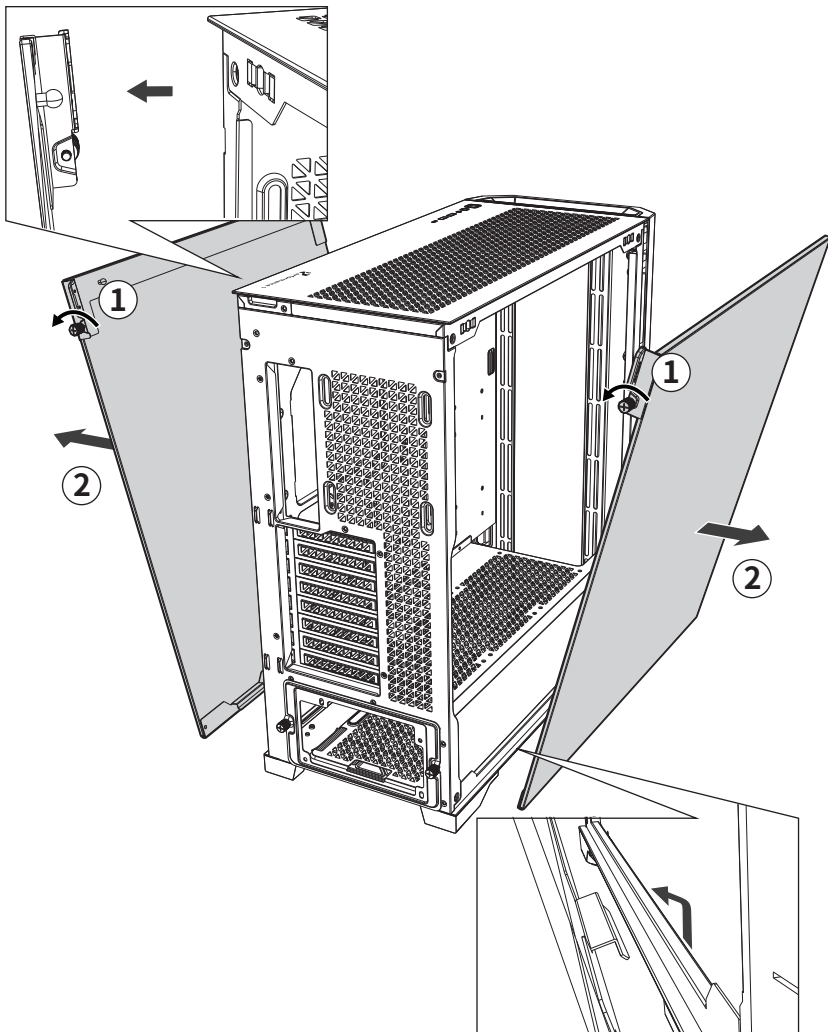

## 2 MOTHERBOARD INSTALLATION

Installation der Hauptplatine | Installation de la Carte-Mère | Installazione della scheda madre | Instalación de placa base | 安裝主機板 | 安裝主板 | 메인보드 설치 | 마ザー보드設置

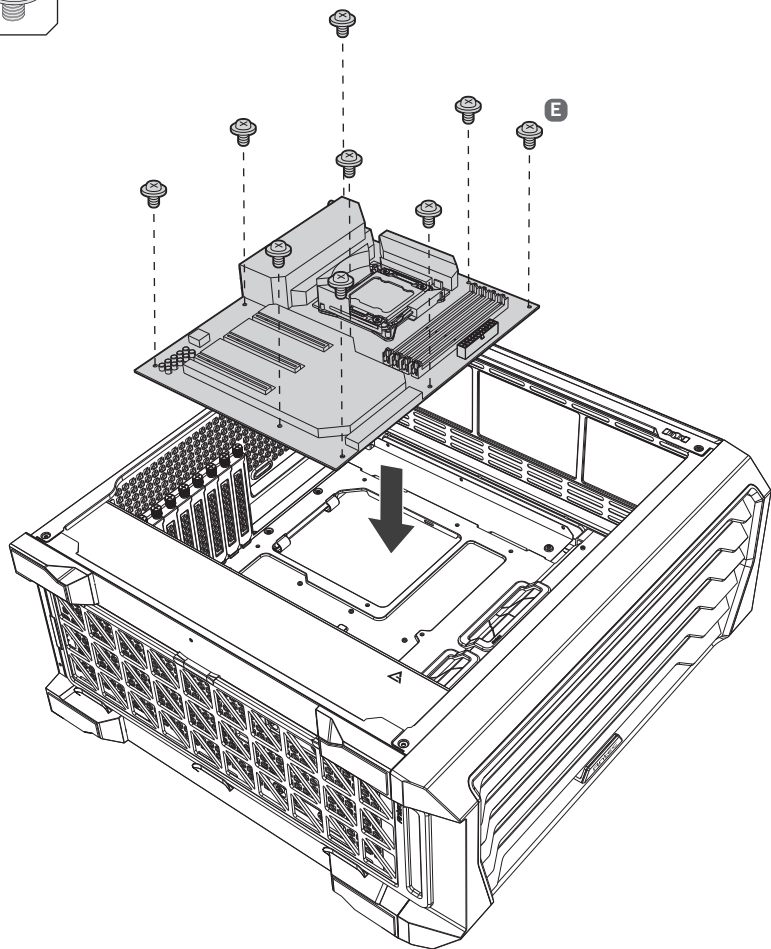
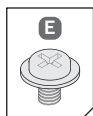

# INSTALLATION GUIDE

## 3 VGA / PCI-EXPRESS CARD INSTALLATION

Installation der VGA/PCI-Express-Karte | Installation de la Carte Graphique | Istallazione della scheda VGA / PCI-Express |  
Instalación de tarjeta VGA/PCI-Express | 安裝VGA/PCI-E卡 | 安裝VGA/PCI-E顯卡 | VGA / PCI-익스프레스 카드 설치 | VGA / PCI-E카드  
의設置

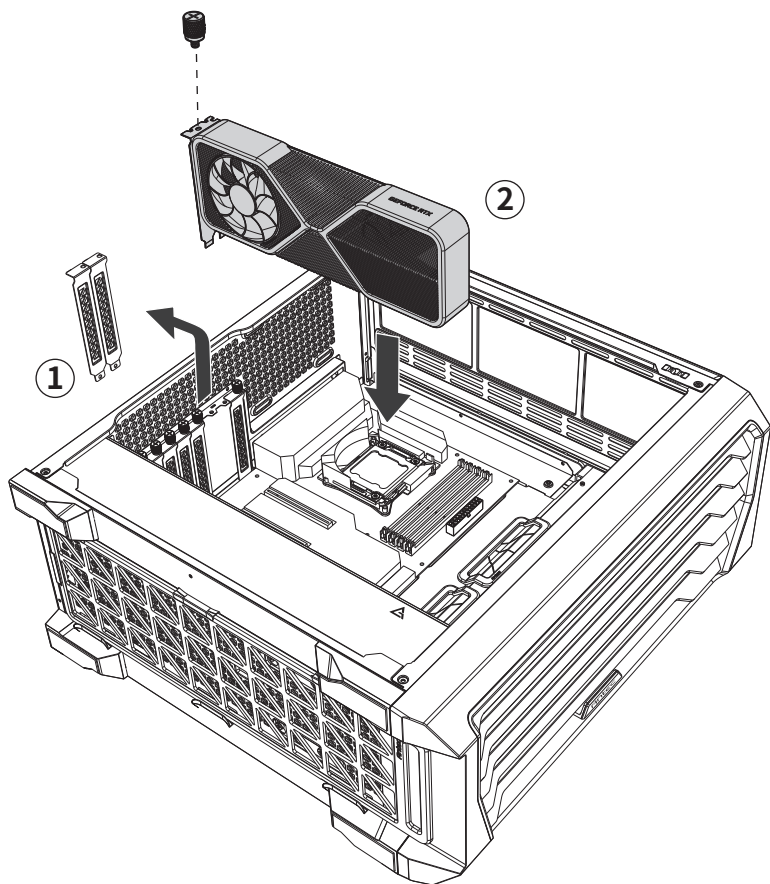

## 4 POWER SUPPLY INSTALLATION

Installation des Netzteils | Installation du Bloc d'Alimentation | Istallazione dell'alimentatore di rete | Instalación de fuente de alimentación | 安裝電源供應器 | 安裝電源 | 파워 서플라이 설치 | 電源設置

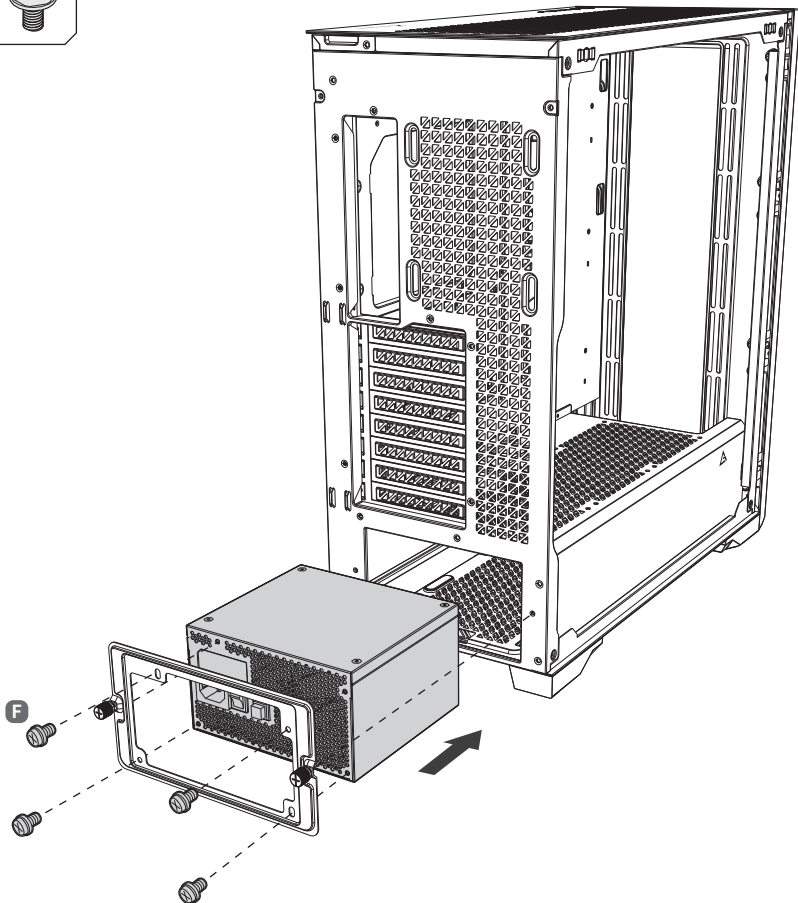
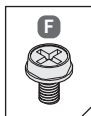

# INSTALLATION GUIDE

## 5 HARD DISK INSTALLATION

Festplatteninstallation | Installation des Disques Durs | Istallazione del disco rigido | Instalación de disco duro | 安裝硬碟 | 安裝  
硬盘 | 하드 디스크 설치 | ハードディスクの設置

### [A] INSTALLING A 2.5" SOLID STATE DRIVE

Installation einer 2,5" SSD (Solid State Drive) | Installer un Disque Dur/SSD 2,5" | Istallazione di un disco a stato solido da 2,5" | Instalación de disco de estado  
sólido de 2,5" | 安裝2.5吋SSD固態硬碟 | 安裝2.5吋SSD固態硬盘 | 2.5" SSD 설치 | 2.5インチソリッドステートドライブの設置

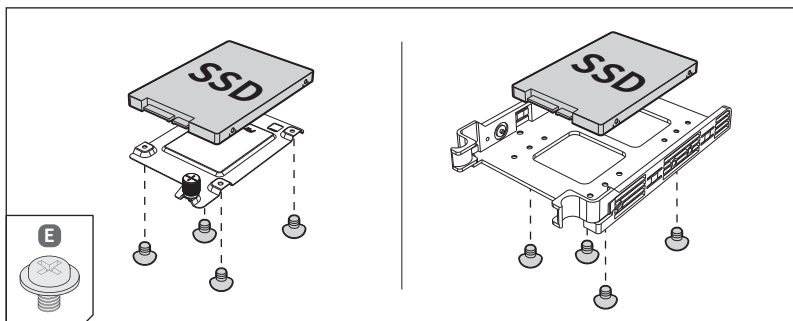
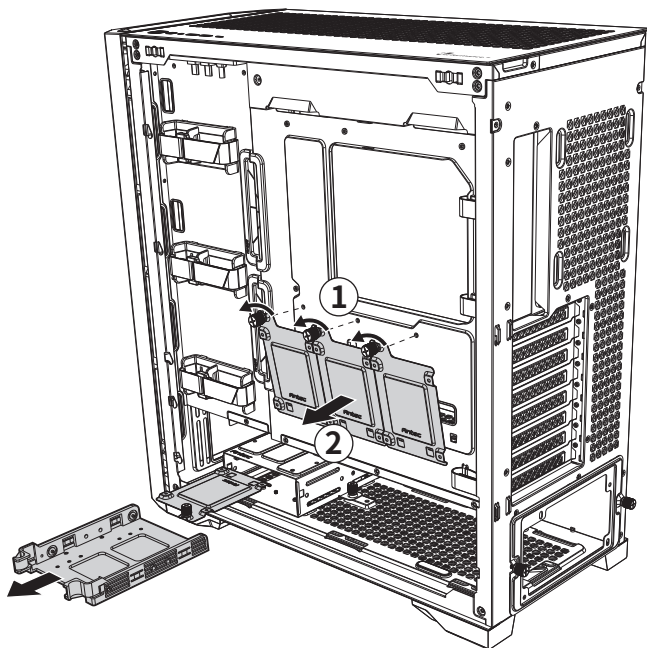

## [B] INSTALLING A 3.5" HARD DISK DRIVE

Installation einer 3,5" Festplatte | Installer un Disque Dur 3,5" | Installazione di un disco rigido da 3,5" | Instalación de unidad de disco duro de 3,5" | 安裝3.5吋HDD硬碟  
安裝3.5吋HDD硬碟 | 3.5" 하드 디스크 드라이브 설치 | 3.5인치하드디스크의設置

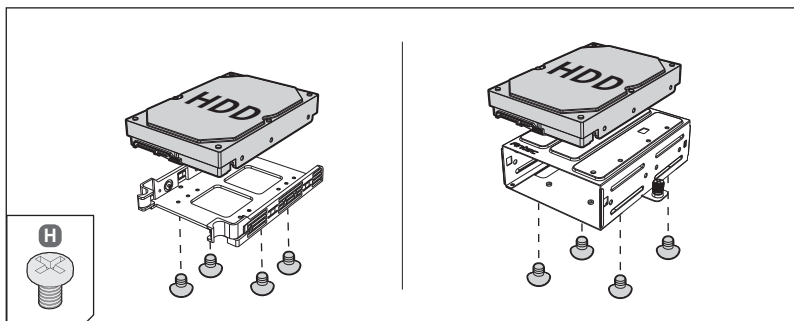
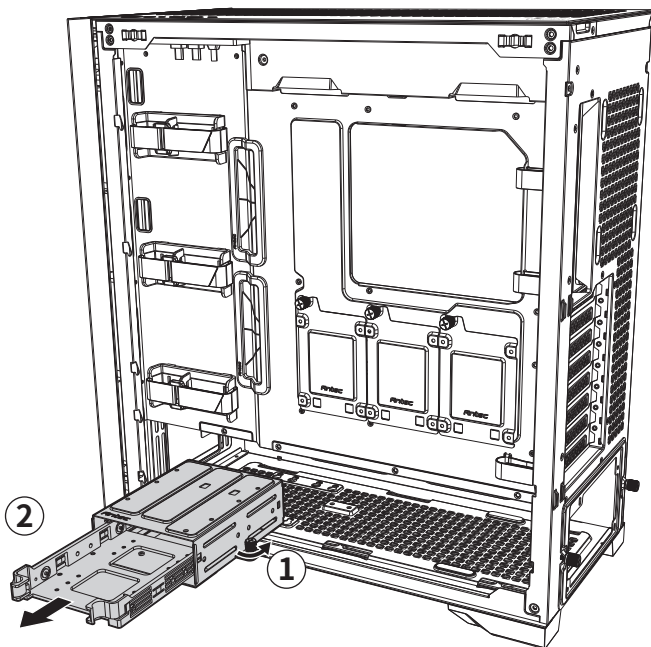

# INSTALLATION GUIDE

## 6 FAN INSTALLATION

Installation des Lüfters | Installation des Ventilateurs | Istallazione del ventilatore | Instalación de ventilador | 安裝風扇 | 安裝風扇 | 팬 설치 | ファンの取り付け

### [A] FRONT & REAR FAN

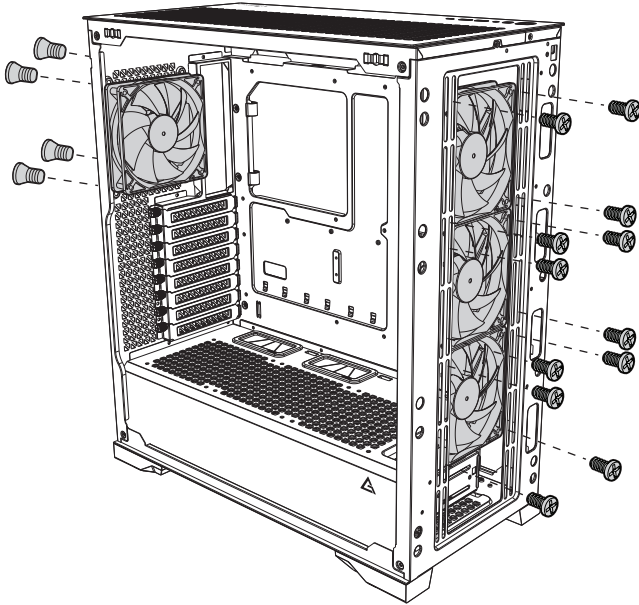

### [B] POWER SUPPLY SHROUD FAN

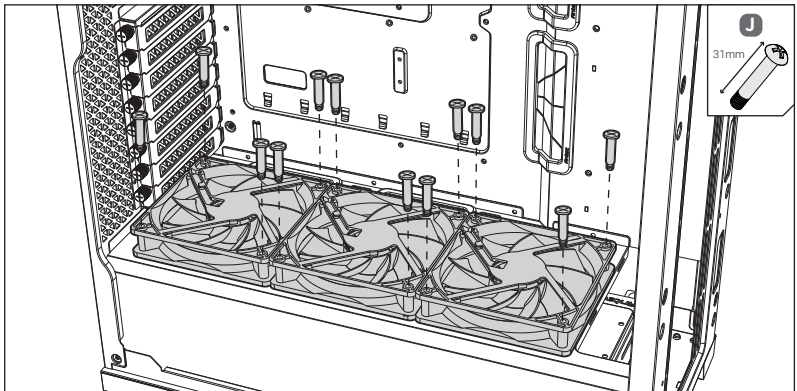

[C] TOP FAN

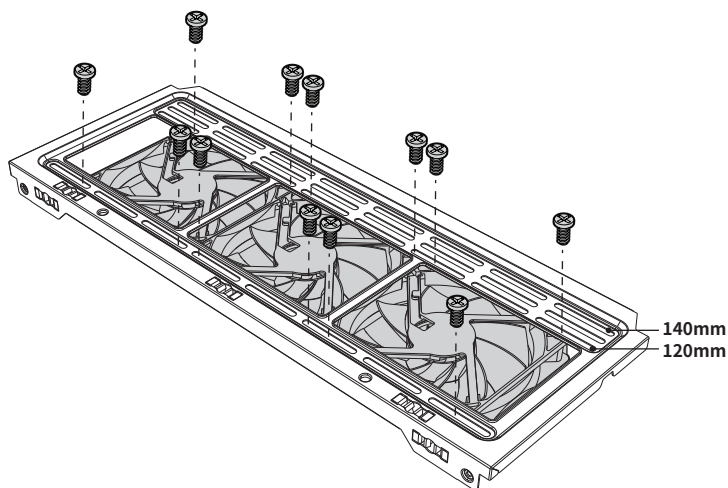
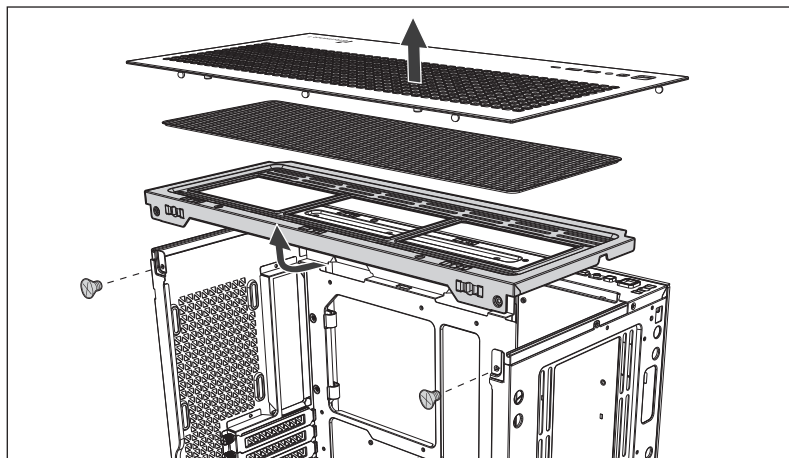



# INSTALLATION GUIDE

## 7 LIQUID COOLING RADIATOR INSTALLATION

Installation des Kühlers für die Flüssigkeitskühlung | Installation des Radiateurs Watercooling | Installazione del radiatore di raffreddamento liquido | Instalación de radiador de refrigeración líquida | 安裝水冷散熱器 | 安裝水冷散熱器 | 액체 냉각 라디에이터 설치 | 液体冷却ラジエーターの設置

### [A] FRONT RADIATOR

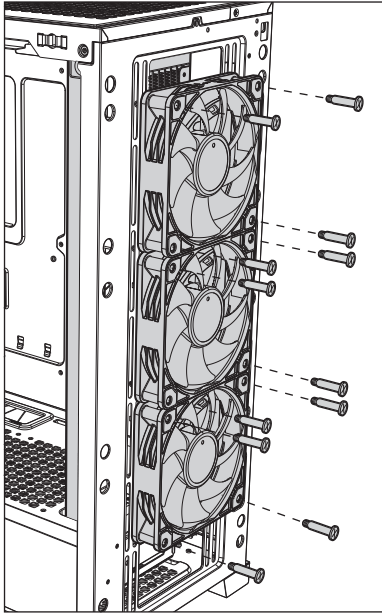

\*To install a 420mm radiator, must remove the top cooling bracket.

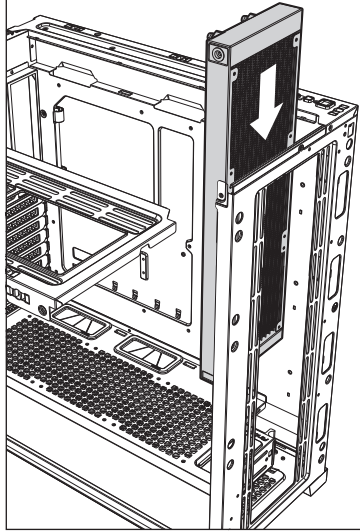

### [B] REAR RADIATOR

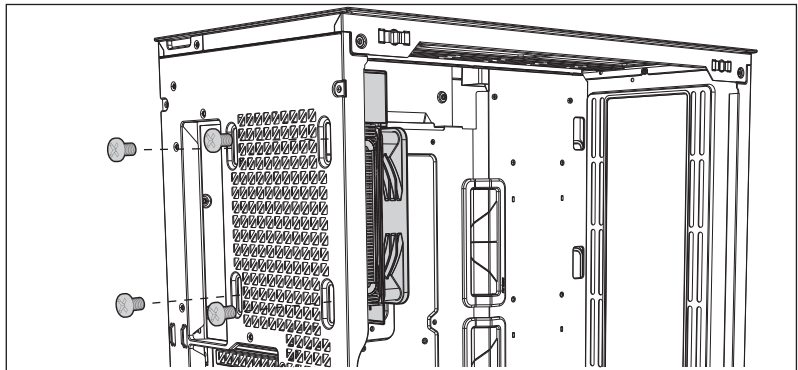

[C] TOP RADIATOR

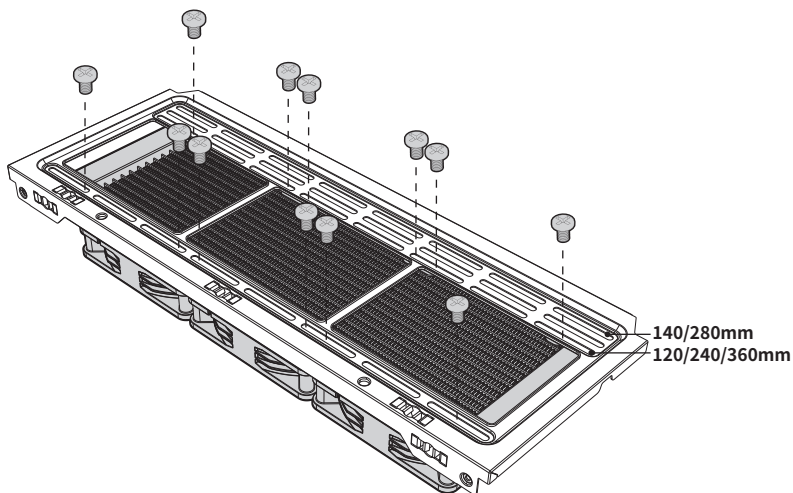
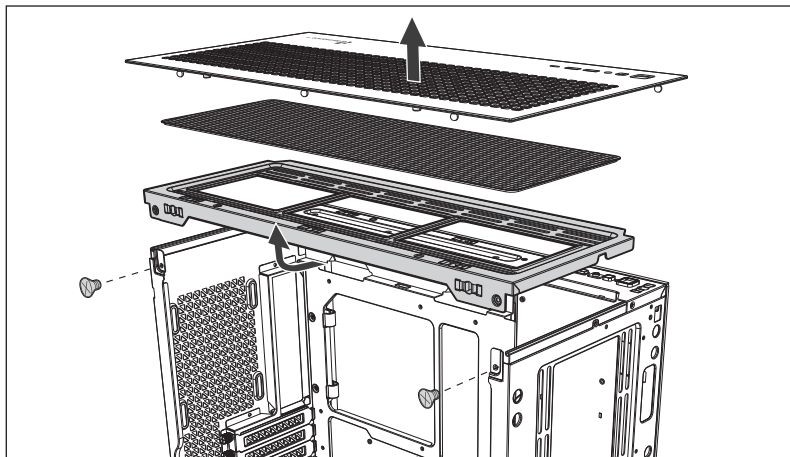

# INSTALLATION GUIDE

## 8 ROUTING SUGGESTION

Vorschlag kabelführung | Suggestions d'installation | Suggerimento percorso cavi | Sugerencia de routing | 整線建議 | 整線建議  
| 작업공정 제한 | おススメの配線

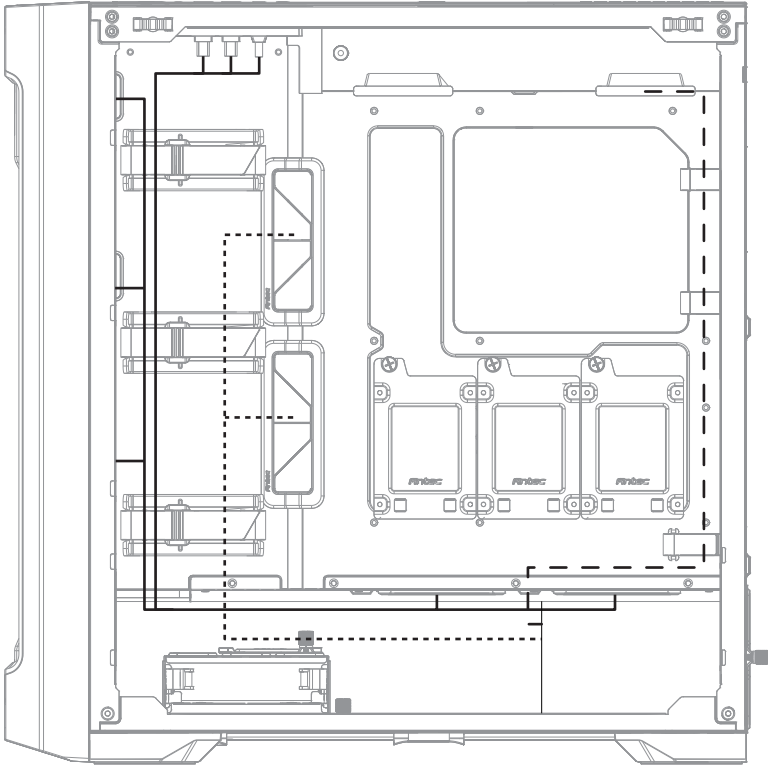

————— Fan & I/O power cable

----- Motherboard / GPU power cable

- . - . - . CPU power cable

## 9 CABLE MANAGEMENT IN THE BACK

Kabelmanagement hinten | Cable management arrière | Gestione cavi nella parte posteriore | Organización del cableado atrás |  
後方整線區 | 后方整線区 | 후면 선정리 | 리아의配线

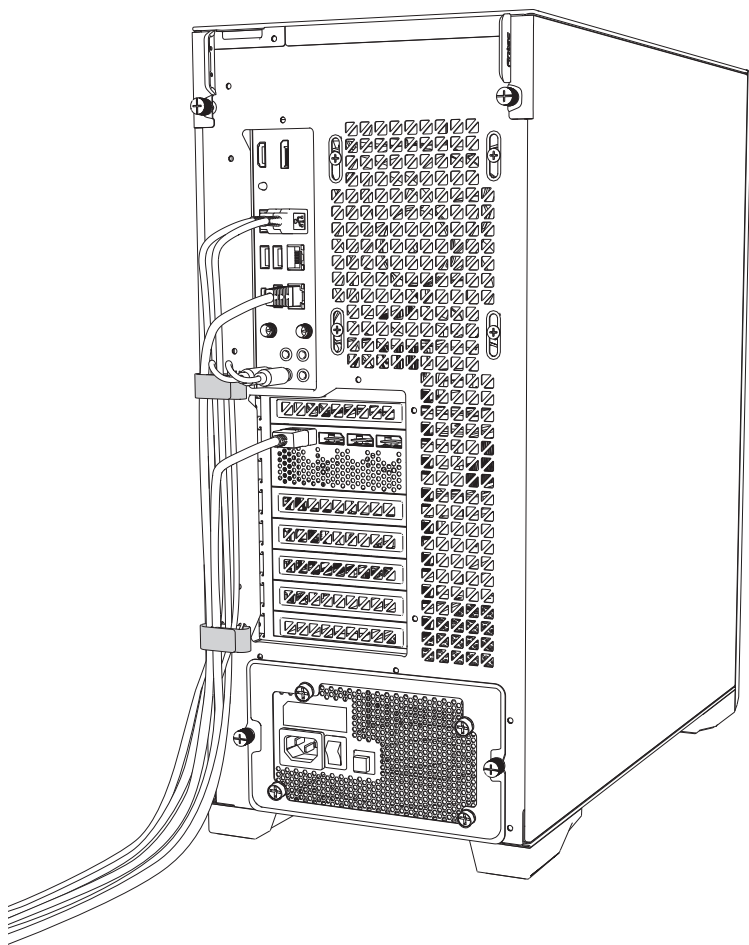

# MEMO



# MEMO

