

**Honeywell**

# PC42E-T

Desktop Printer



---

**User Guide**

---

# Disclaimer

Honeywell International Inc. (“HII”) reserves the right to make changes in specifications and other information contained in this document without prior notice, and the reader should in all cases consult HII to determine whether any such changes have been made. HII makes no representation or warranties regarding the information provided in this publication.

HII shall not be liable for technical or editorial errors or omissions contained herein; nor for incidental or consequential damages resulting from the furnishing, performance, or use of this material. HII disclaims all responsibility for the selection and use of software and/or hardware to achieve intended results.

This document contains proprietary information that is protected by copyright. All rights are reserved. No part of this document may be photocopied, reproduced, or translated into another language without the prior written consent of HII.

Copyright © 2023 Honeywell Group of Companies. All rights reserved.

Web Address: [sps.honeywell.com](https://sps.honeywell.com)

# Trademarks

Microsoft® Windows® and the Windows logo are trademarks or registered trademarks of Microsoft Corporation.

Wi-Fi is a registered certification mark of the Wi-Fi Alliance.

Bluetooth is a trademark of Bluetooth SIG, Inc., U.S.A.

Google™, Android™ and Google Play Store™ are registered trademarks of Google, LLC.

Zebra and Eltron® is a trademark or registered trademark of Zebra Corporation.

Other product names or marks mentioned in this document may be trademarks or registered trademarks of other companies and are the property of their respective owners.

# Patents

For patent information, refer to [www.hsmpats.com](https://www.hsmpats.com).

# Customer Support

## Technical Assistance

To search our knowledge base for a solution or to log into the Technical Support portal and report a problem, go to [honeywell.com/PSSTechnicalsupport](https://honeywell.com/PSSTechnicalsupport).

## Product Service and Repair

Honeywell International Inc. provides service for all of its products through service centers throughout the world. Go to [sps.honeywell.com](https://sps.honeywell.com) and select **Support** to find a service center near you or to get a Return Material Authorization number (RMA #) before returning a product.

## Limited Warranty

For warranty information, go to [sps.honeywell.com](https://sps.honeywell.com) and select **Support > Warranties**.

## Safety Warnings



**Warning:** Moving parts are exposed when the cover is open. Make sure the cover is closed before you operate the printer.

**Warning:** The printhead/motor may be hot. Allow the printhead/motor to cool.

**Warning:** Do not put your fingers inside the print mechanism when the power is on.

**Warning:** The tear bar contains sharp edges. Keep fingers and other body parts away from the tear bar.



**Caution:** Read and review the warnings in this manual carefully before connecting the printer.

**Caution:** Observe all safety and accident prevention regulations applicable to your specific region and application.

**Caution:** Do not spray the printer with water. If you are using a host to clean the premises in an industrial environment, remove the printer or protect it carefully from spray and moisture.

**Caution:** You must implement both hardware and software safety precautions to prevent the possibility of undefined system states.

**Caution:** You must make sure that dangerous conditions cannot occur under any circumstances, even for a brief period of time.

**Caution:** Carefully read the warning text on the envelope before using a cleaning card.

**Caution:** To reduce the risk of electric shock or fire, keep the cover closed and turn off the printer when not in use. No user-serviceable parts inside.

# TABLE OF CONTENTS

Customer Support .....	iii
Technical Assistance .....	iii
Product Service and Repair .....	iii
Limited Warranty .....	iii
Safety Warnings .....	iv
<b>Chapter 1 - About the Printer features .....</b>	<b>1</b>
About the Printer .....	1
Printer Features .....	2
About the Print Button .....	3
About the ECO Button .....	3
About the Status LED .....	4
About Media .....	4
Load Tear-Off Media .....	5
Load External Media .....	10
Load Ribbon .....	10
Connect the Printer to Power .....	16
About Printer Command Languages .....	16
Autosense .....	17
Direct PDF Printing .....	17
Direct Protocol .....	17
DPL .....	17
ESim .....	17
Fingerprint .....	17
IPL .....	18

ZSim.....	18
How to Set the Printer Command Language.....	18
Set the Command Language with the Print Button.....	18
Set the Command Language from the Printer Web Page .....	19
Set the Command Language from PrintSet 5 .....	19
About Test Labels .....	19
Print a Test Label When You Turn on the Printer.....	20
Print a Test Label When the Printer is Ready to Print.....	20

## **Chapter 2 - Connect the Printer ..... 21**

Printer Drivers .....	21
Install Honeywell Windows Driver .....	21
How to Connect the Printer to Your PC.....	22
Connect the Printer with a USB Cable .....	22
Connect the Printer with a USB-to-Serial Cable.....	22
Connect the Printer to Your Network.....	22
Connect the Printer to an Ethernet Network.....	22
Connect the Printer via Wi-Fi .....	23
Configure Bluetooth Communication.....	25
Configure Bluetooth Communication from the Web Page .....	25
Configure Bluetooth Communication from PrintSet 5 .....	25
USB Host Port .....	25
Connect a USB Device.....	26
Configure the Printer.....	26
Configure the Printer from the Printer Web Page.....	26
Configure the Printer with PrintSet 5 .....	27
Upgrade the Firmware .....	27
Download the Printer Firmware Update.....	27
Upgrade Firmware from the Printer Web Page .....	28
Upgrade Firmware from PrintSet 5.....	28
Upgrade Firmware from a USB Storage Device .....	28

**Chapter 3 - Troubleshoot and Maintain the Printer .....29**

- Locate the Printer Configuration and Serial Numbers .....29
- Printer Problems and Possible Solutions .....29
- How to Restore Default Settings .....30
- Restore Default Settings with the Print Button.....30
  - Restore Default Settings from the Printer Web Page.....31
  - Restore Default Settings with PrintSet 5.....31
- Clean the Printhead .....31
- Replace the Printhead.....32
- Clean the Platen Roller .....34
- Clean the Interior of the Printer.....36
- Clean the Exterior of the Printer.....36

**Appendix A - Specifications .....37**

- Specifications and Resources .....37
- Media Specifications .....37
- Print Sensors.....38
- Fonts.....38
  - Resident Fonts .....38
  - Downloadable Fonts.....39
  - Supported Font Types.....39
  - Printed Barcode Symbologies .....39
  - Graphic File Types .....41

**Appendix B - Default Settings .....43**

- Default Configuration .....43
  - Ethernet Settings.....43
  - Media Settings.....44
  - Print Quality Settings.....47
  - General System Settings .....47
  - Manage I/O Settings.....48
  - Manage Services Settings .....49

DNS Network Services.....	49
Net1 Network Services.....	50
Email Server .....	50
WINS Network Services.....	51
Web Server Network Services.....	51
Connectivity Agent .....	51
XML Printing .....	52
Device Management.....	52

**Appendix C - Print Labels with INPrint..... 53**

The INPrint Page .....	53
Print INPrint Labels.....	53

**Appendix D - Installing Accessories ..... 55**

Cutter Module .....	55
Out of the Box.....	55
Installation.....	55
Peel-Off Module.....	58
Out of the Box.....	58
Installation.....	58
Bluetooth/Wi-Fi Module.....	62
Out of the Box.....	62
Installation.....	62



# ABOUT THE PRINTER FEATURES

This chapter introduces the PC42E-T printer. It includes descriptions of the printer features and basic operation.

## About the Printer

The PC42E-T printer is a lightweight, reliable printer that is easy to use. It is designed to print up to 1500 labels a day. Printer features include:

- 203 dpi (6 ips) or 300 dpi (5 ips) printing.
- USB host port for connecting storage devices, scanners, or keyboards.
- USB device port for connecting to a desktop PC.
- Honeywell PrintSet 5 support.
- Support for printer programming languages, including Datamax Printer Language (DPL), Direct PDF Printing, Direct Protocol (DP), Eltron Simulation (ESim), Fingerprint (FP), Intermec Printer Language (IPL), and Zebra Simulation (ZSim).
- Optional Ethernet interface.

# Printer Features

Use these illustrations to locate printer features.

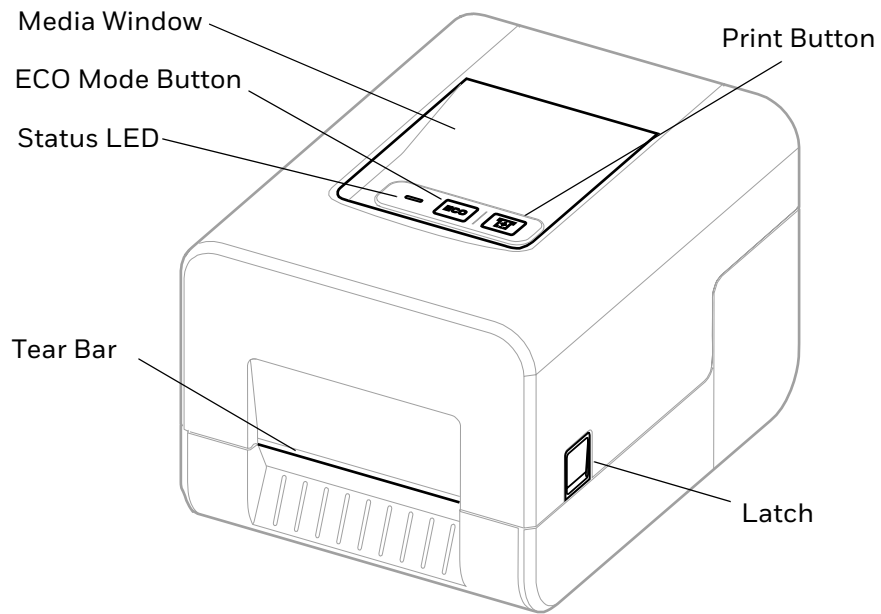

**Front**

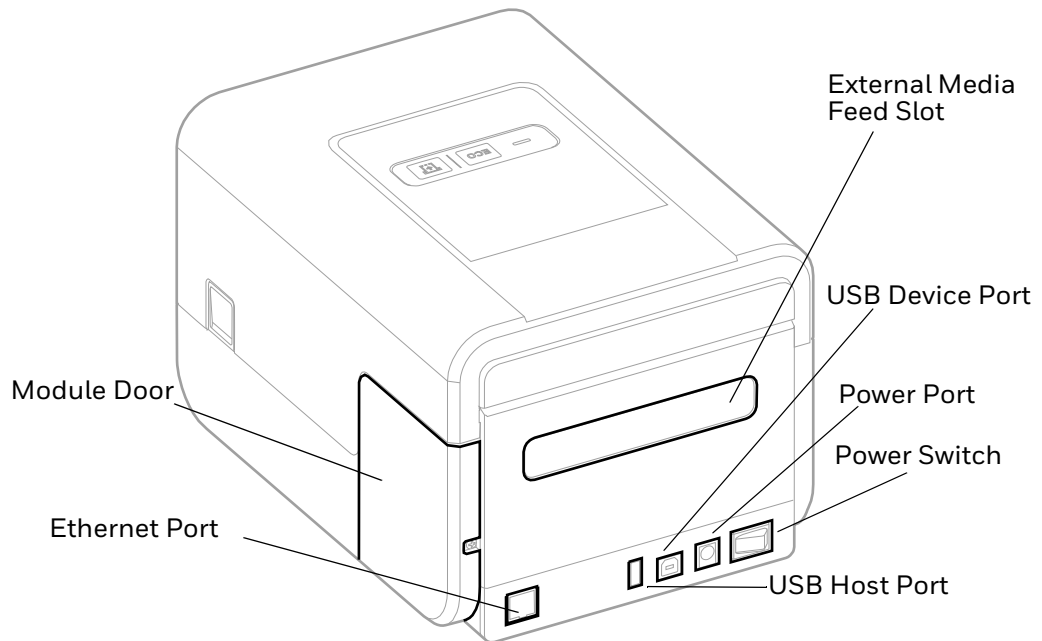

**Rear**

# About the Print Button

Use the next table to understand the functions of the **Print** button.

<b>Print Button Action</b>	<b>Description</b>
Press and hold the <b>Print</b> button (while the printer is starting up)	The printer calibrates the media, prints a configuration label, and then lets you select the printer command language. Press the <b>Print</b> button when the printer command language you want to use prints out.
Press and hold the <b>Print</b> button for two seconds and then release (when the printer is idle)	The printer prints out several labels to calibrate the media sensor (testfeed).
Press and hold the <b>Print</b> button for six seconds (when the printer is idle)	The printer prints out several labels (testfeed) and then prints the configuration label.
Press and release the <b>Print</b> button	If the printer is idle, the printer advances media to the beginning of the next label. If the printer is printing, the printing pauses. If the printer has been paused, printing resumes.
Press and hold the <b>Print</b> button for three seconds	If the printer is paused, the print job is canceled and any print jobs inside the printer are discarded. The printer returns to the idle state.

# About the ECO Button

Use the next table to understand the functions of the **ECO** button.

Press the **ECO** button to turn ECO mode on and off.

<b>ECO Button Action</b>	<b>Description</b>
Green (on)	ECO mode is on. The fast media calibration feature is active and the printer media calibration process will use a minimal length of labels. Use ECO mode to conserve media.
Blank (off)	ECO mode is off. The slow media calibration feature is active and the printer media calibration process will use the length of multiple labels. Use slow calibration if the printer has trouble identifying gaps or marks in media.

## About the Status LED

The status LED turns green, orange, or red to indicate the current status of the printer. Use the next table to understand the states of the status LED.

LED State	Description
Off	Power is turned off.
Green (solid)	The printer is idle and waiting for the next print job.
Green (blink from start up)	The printer is experiencing a memory error. You need to upgrade the firmware. For help, see <a href="#">Upgrade the Firmware</a> on page 27.
Green (blink)	The printer is starting up. Printing is paused. Press the <b>Print</b> button to resume printing or press and hold the <b>Print</b> button for three seconds to cancel the print job.
Green (fast blink)	The printer is communicating. The simulator (ZSim and ESim) is starting up.
Green (slow blink)	In peel off mode, a printed label is available in the output slot. The printer will not print another label until the label in the output slot is removed.
Orange (solid)	The printhead is too hot. Wait for the printhead to cool down to an acceptable temperature before it can resume printing.
Orange (blink)	The printer is upgrading its firmware from an inserted USB flash drive. Remove the USB flash drive after the LED turns solid green.
Orange (slow blink)	The print job includes a font that is not installed or includes a location that is outside the available print area.
Red (blink)	The printer is in Error mode. The printer may be out of ribbon, have ribbon installed when configured for direct thermal, be out of media, have the printhead lifted, have a label obstructing the printing path, or you may not have performed a testfeed (hold <b>Print</b> button until several labels print). After you have fixed the error, press the <b>Print</b> button to restart printing.
Red and green (alternating blink)	The printer is experiencing a hardware issue. Return the printer to Honeywell for service. For help, see <a href="#">Product Service and Repair</a> on page iii.

## About Media

The printer can print on labels, tags, and continuous (receipt and lined) media. The printer supports both direct thermal and thermal transfer media. To use thermal transfer media, you also need thermal transfer ribbon. The printer supports media from 1 to 4.5 inches (25 to 114 mm) wide.

# Load Tear-Off Media

In tear-off printing mode, you manually tear off the media upward against the tear bar.

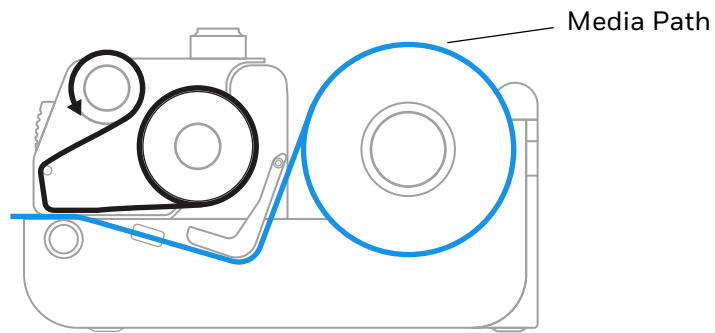

1. Press in on the cover latches on both sides of the printer and open the cover.

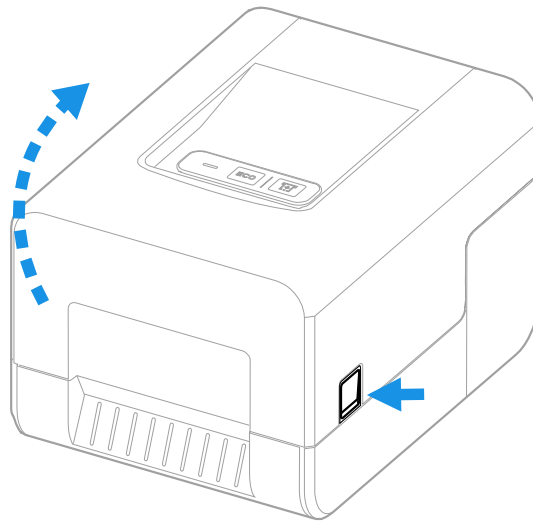

**Caution: Open the cover completely to ensure that it does not close shut while you are loading media.**

2. Pull up the lock on the left media hub and slide the media hubs to accommodate the width of the media roll.

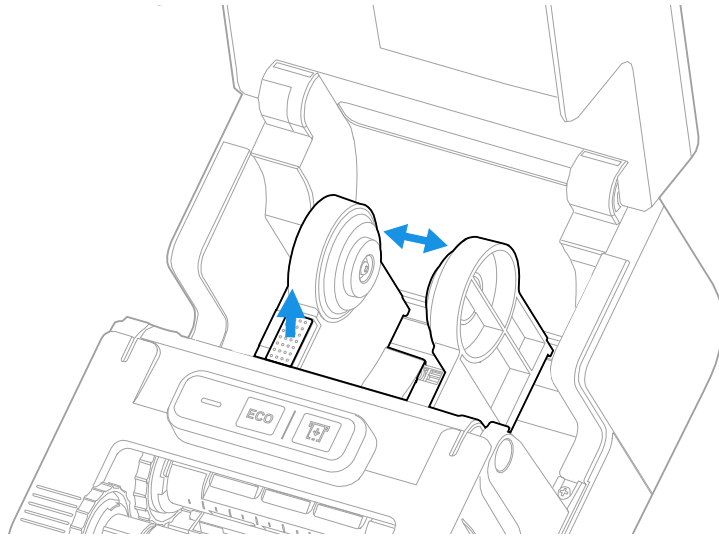

3. Insert the media roll between the media hubs as shown.

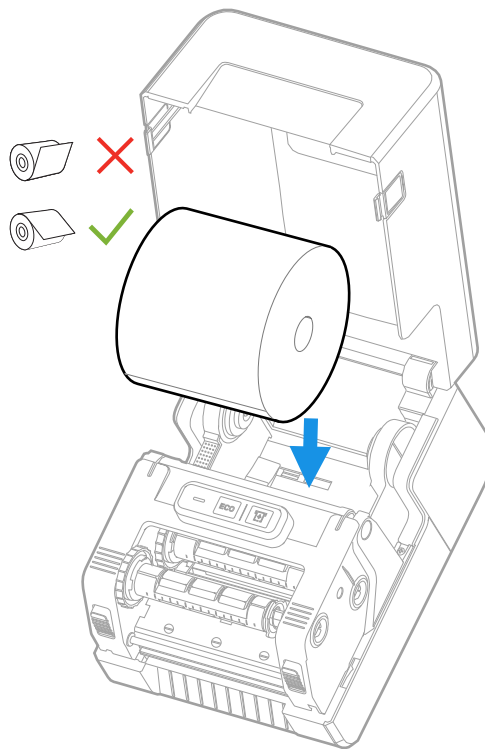

4. Make sure the media hubs are snug against the sides of the media roll, and then press the locking tab down to lock the media hubs in place.

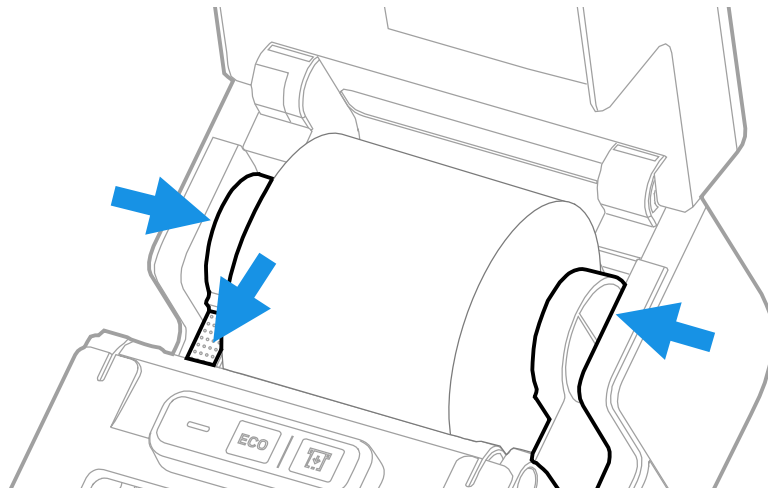

5. Press in both locking buttons to open the print and ribbon mechanism.

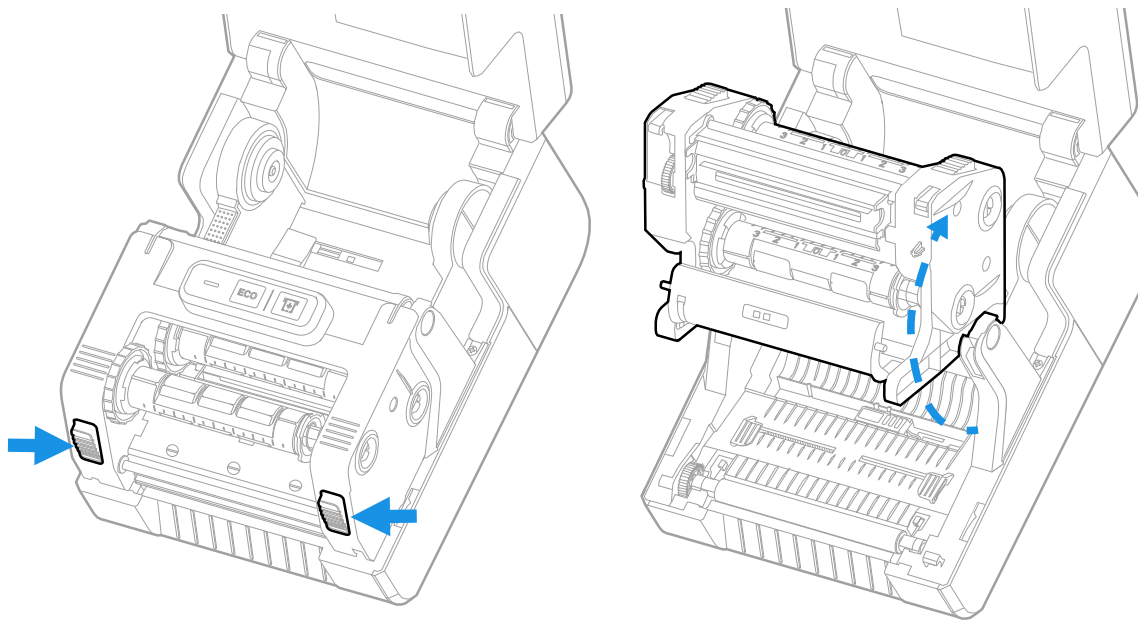

6. Adjust the media sensor according to type of media: black mark, gap, or cloth tag and other media. Slide the tab in the middle of the sensor to the location of the media type.

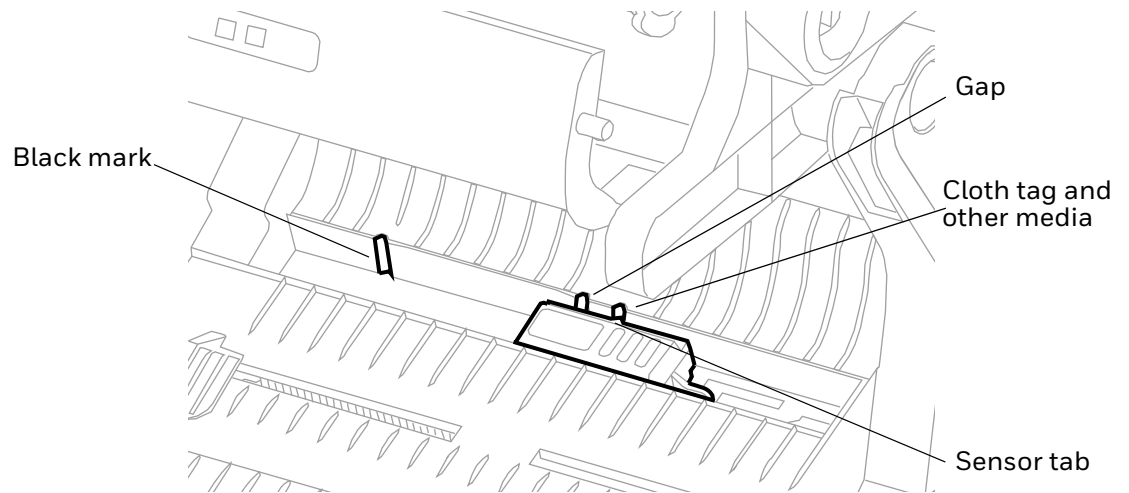

5. Feed the media underneath the print and ribbon mechanism and to the front of the printer.
6. Place the media between the media holders, and adjust the media holders to the width of the media. Ensure the media lays flat.

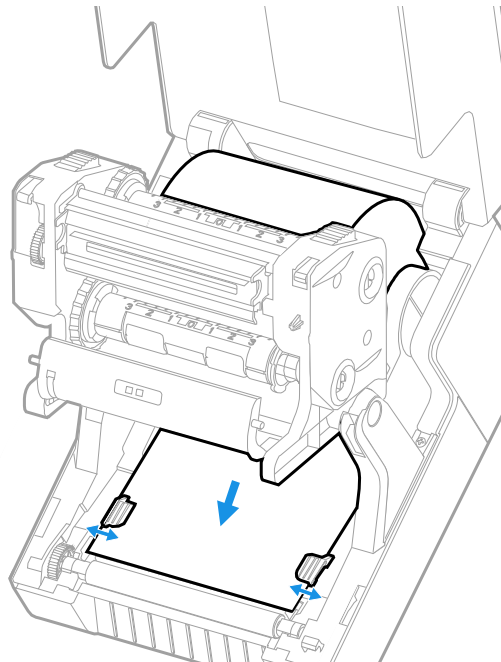



7. Ensure that the media extends beyond the cutter area in front of the printer. Lower the print and ribbon mechanism and press down until both locking tabs snap into place.

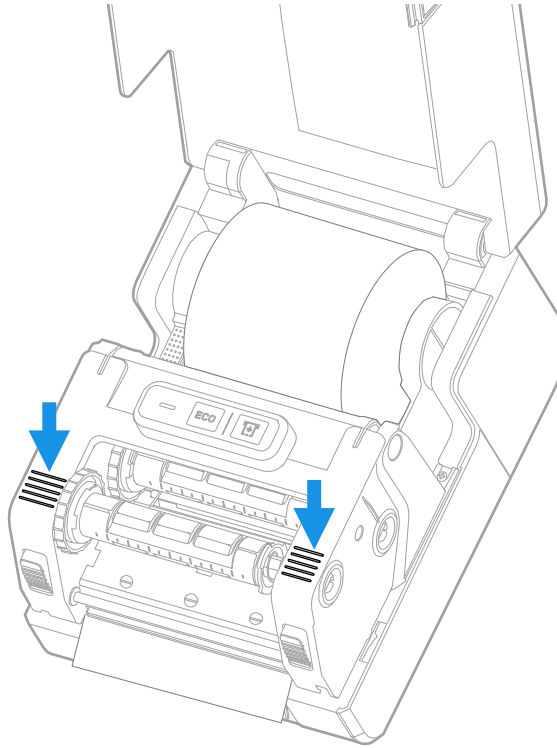

8. Close the cover.
9. Make sure you configure these printer settings:
  - Thermal transfer or direct thermal printing
  - Media type
  - Media width and length
10. Press and hold the **Print** button to print a test label. For help, see [About Test Labels](#) on page 19.

## Load External Media

You can place the media supply, such as fanfold tickets or tags, behind the printer. You need to purchase an external media holder separately.

**Note:** *Protect the media from direct sunlight and from dust, dirt, or other foreign particles that can impair the printout quality or cause unnecessary wear to the printhead.*

1. Place the media behind the printer.
2. Feed the media into the printer through the external media feed slot.

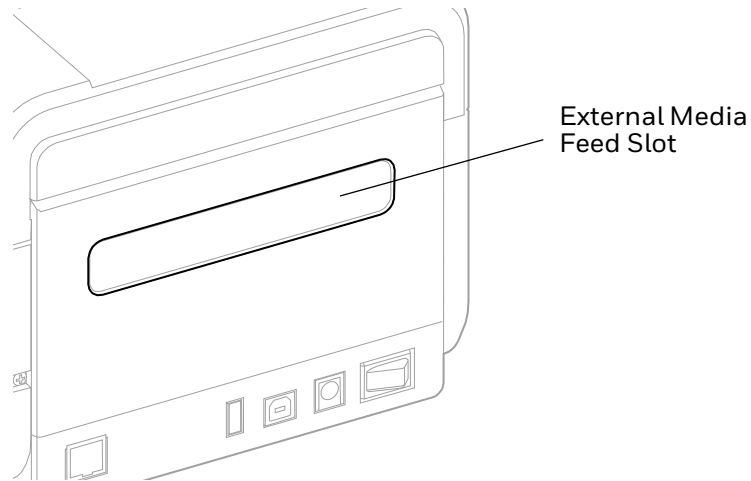

3. Thread the media through the printer and adjust the media holders and sensor as you would for media that loads inside the printer.

## Load Ribbon

You must use thermal transfer ribbon to print on thermal transfer media. Make sure to select ribbon that matches the face materials of the media to obtain the best durability and print quality.

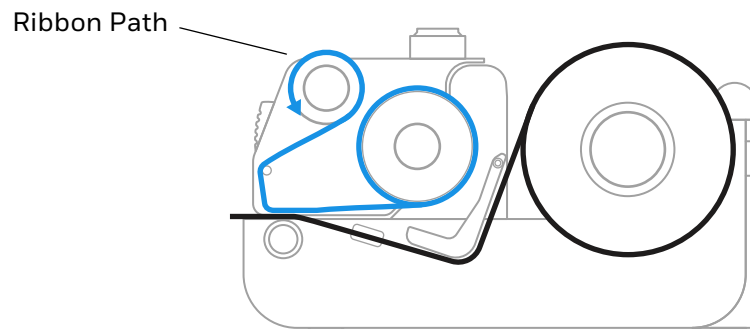

**Note:** The printer can only use ribbon that is “ink out,” which means that the ribbon is loaded with the inked side (dull side) facing out.

1. Press in on the cover latches on both sides of the printer and open the cover.

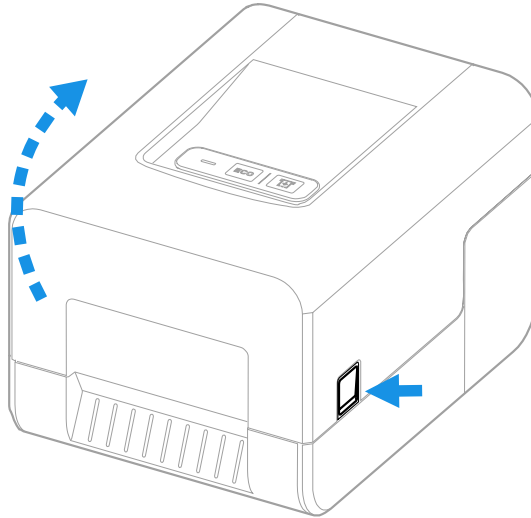

**Caution: Open the cover completely to ensure that it does not close shut while you are loading the ribbon.**

2. Adjust the ribbon core switches according to the diameter of the ribbon core:
  - For 1/2 inch ribbon cores, the ribbon core switch must be in the outward position. Hold the ribbon turnplate for the switch and use a Phillips screwdriver to push in and turn the switch counter clockwise.
  - For 1 inch ribbon cores (or if you are using the ribbon adapter), the ribbon core switch must be in the inward position. Hold the ribbon turnplate for the switch and use a Phillips screwdriver to push in and turn the switch clockwise.

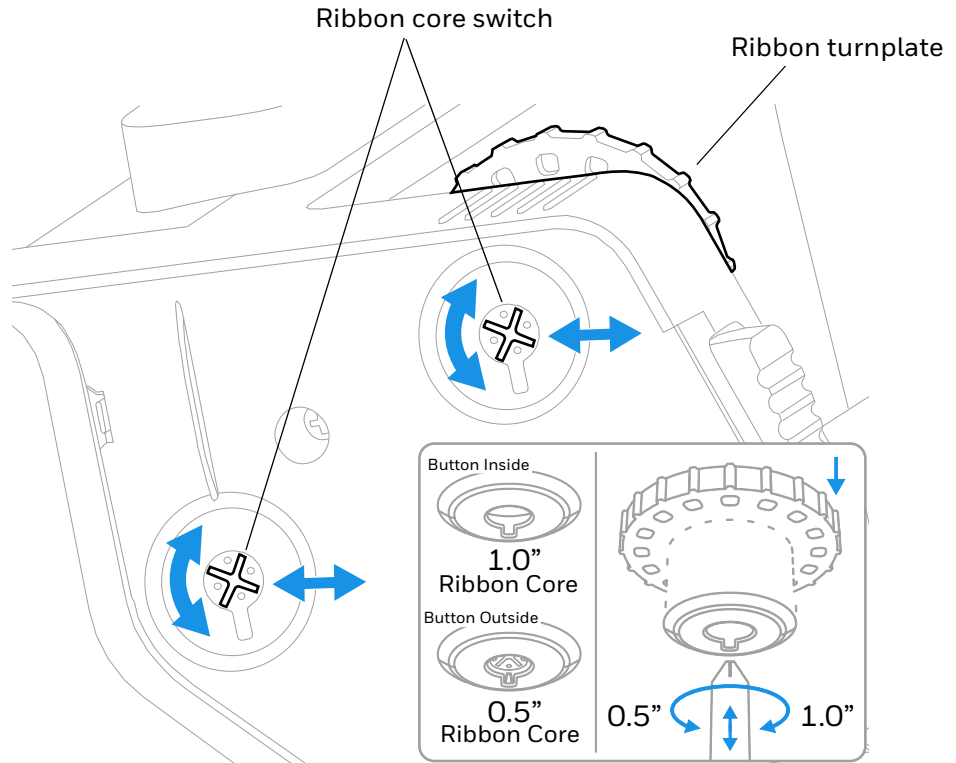

3. Press in both locking buttons to open the print and ribbon mechanism.

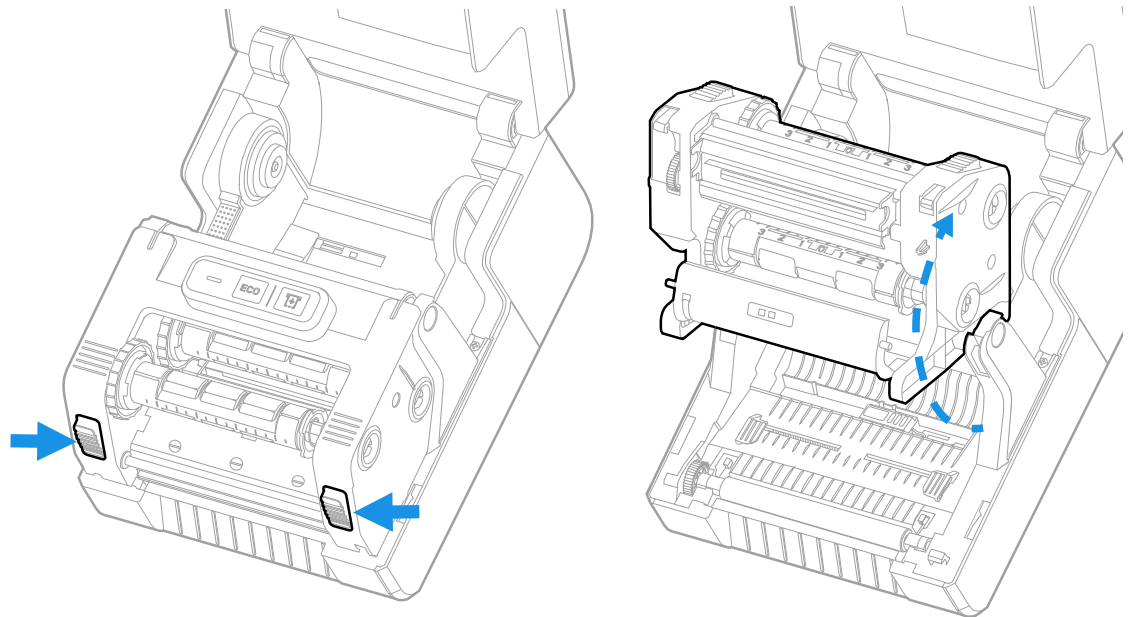

4. Lower the ribbon cover.

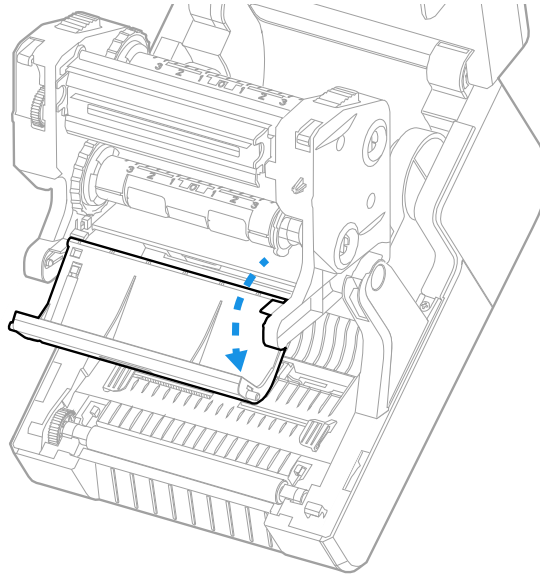

5. For a 1 inch ribbon core, insert a ribbon adapter into the thermal transfer ribbon roll. The ribbon should come off of the roll as shown in the following illustration.

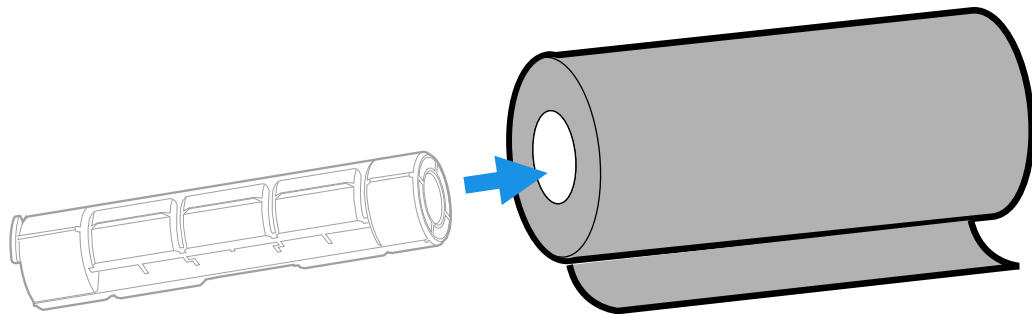

If your media is not very wide, center the ribbon core on the ribbon adapter.



6. Place the thermal transfer ribbon roll between the rear ribbon holders. The ribbon should come off of the roll as shown in the following illustration.

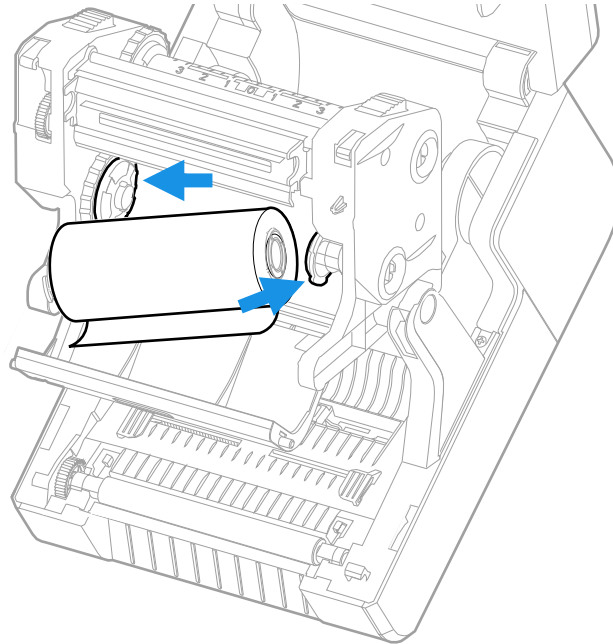

7. Insert an empty takeup core into a ribbon adapter.
8. Pull the ribbon over the printhead and place the end of the thermal transfer ribbon over the empty takeup core as shown in the following illustration. You can use tape to fasten the ribbon to the core.

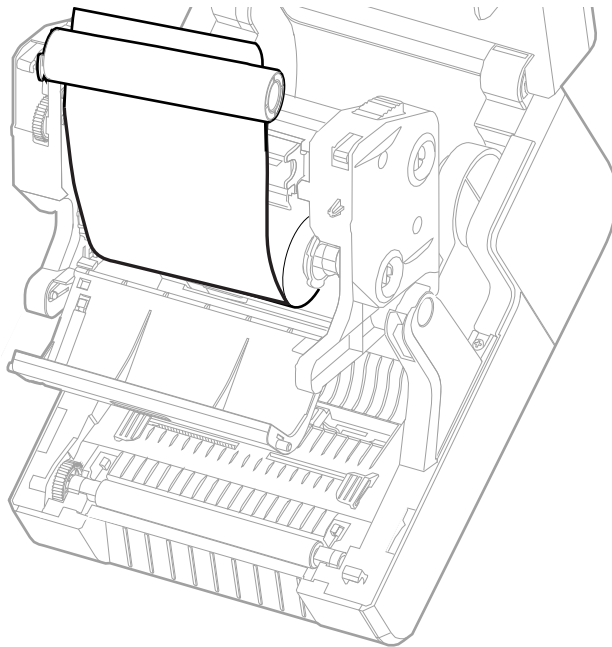

9. Install the ribbon takeup core. Take up slack in the ribbon, making sure that the ribbon surface is smooth and the ribbon is winding correctly. Turn the ribbon turnplate until it clicks into place to secure the takeup ribbon core.

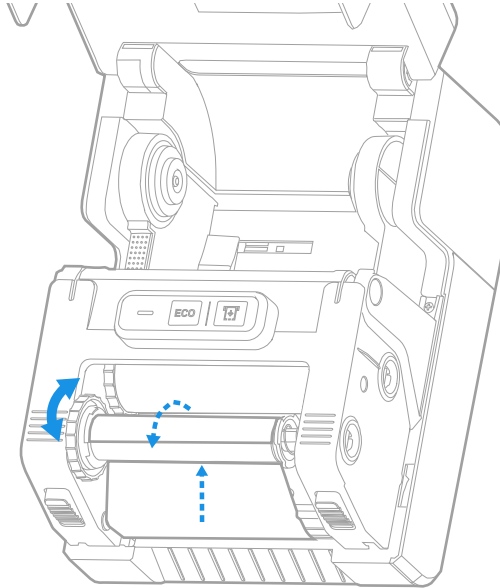

10. Lower the print and ribbon mechanism and press down until it locks into place.

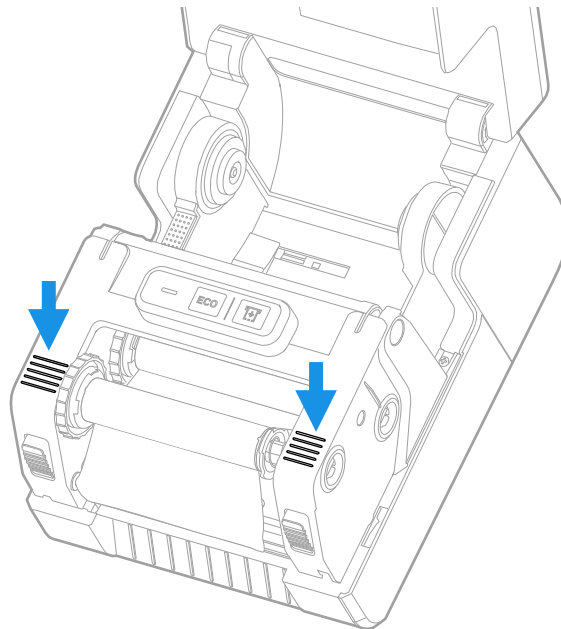

11. Close the printer cover.

12. Make sure you configure these printer settings:

- Thermal transfer printing
- Media type
- Media width and length

13. Press and hold the Print button to print a test label. For help, see [About Test Labels](#) on page 19.

## Connect the Printer to Power



**Caution: Use only the AC power adapter supplied with the printer. The use of a power adapter not approved by Honeywell voids the product warranty and may damage the printer.**

**Caution: Turn the printer off when not in use.**

1. Connect the power adapter to the power port on the rear of the printer.
2. Connect the power adapter to AC power. When the adapter is connected to AC power, the green LED in the adapter connector turns on and stays on.
3. Press the Power switch to turn the power on. As the printer starts up, the green LED on the printer turns on and blinks.

The green LED turns on solid green when the printer is ready to print.

You can now set the printer command language or print a configuration label. For help, see [How to Set the Printer Command Language](#) on page 18 or [About Test Labels](#) on page 19.

## About Printer Command Languages

A printer command language is a set of instructions that controls printer functions:

- Configure the printer.
- Return the status of the printer.
- Control peripheral devices.
- Format a label or receipt for printing.

The printer supports these command languages and language simulator support options:

- [Autosense](#)
- [Direct PDF Printing](#)
- [Direct Protocol](#)
- [DPL](#)



- [ESim](#)
- [Fingerprint](#)
- [IPL](#)
- [ZSim](#)

## Autosense

Autosense allows the printer to automatically sense from label to label, the incoming data stream, and its language, and to print each label accordingly.

**Note:** *Autosense is the default printer configuration and does not support an IPL data stream.*

## Direct PDF Printing

PDF printing refers to the ability of the printer to directly print PDF files without additional middleware or smart device with generated PDF. If you are sending PDF files to the printer, select PDF printing as your printer command language.

## Direct Protocol

Direct Protocol (DP) uses a more intuitive English-like syntax. Direct Protocol lets you combine predefined layouts and variable data to create labels, tickets, and tags. If you are using barcode software, select Direct Protocol as your printer command language.

## DPL

The DPL command language interprets Datamax™ data streams without requiring any host programming changes. If you are sending DPL label files to the printer, select DPL as your printer command language.

## ESim

ESim (EPL command language simulator) interprets Eltron printer command language. If you send EPL label documents to the printer, you should select ESim as your printer command language.

## Fingerprint

Fingerprint is a BASIC-inspired general purpose printer language. Use Fingerprint to design custom label formats and write printer application software. If you plan to run Smart Printing applications directly on the printer without connecting to a PC, select Fingerprint as your printer command language.

## IPL

IPL is a host-based printer command language. Use IPL to design, modify, and download label formats, write printer application software, and configure the printer. If you are sending IPL label files to the printer, select IPL as your printer command language.

**Note:** *IPL can be supported on 200dpi and 300dpi printers only.*

## ZSim

The ZSim (Zebra Printer Language Simulator) interprets Zebra™ programs (ZPL II or later) without requiring any host programming changes. If you are sending ZPL label files to the printer, select ZSim as your printer command language.

**Note:** *You can use command languages, like Direct Protocol, and language simulators, like ZSim, to create and print labels. For more information, see the command reference manual for your desired language. For details on how to use Smart Printing directly on the printer, see the Fingerprint Command Reference Manual.*

# How to Set the Printer Command Language

You can use one of these methods to change the printer command language:

- **Print** button
- Printer web page (with Ethernet option installed)
- PrintSet 5. For more information, see [Upgrade the Firmware](#) on page 27.

You may need to configure the media type and print method when you set the command language through the printer web page or the printer configuration software (not applicable when setting the printer command language with the **Print** button).

## Set the Command Language with the Print Button

Make sure the printer has media and ribbon (if necessary) installed.

1. Turn off the printer.
2. Press and hold the **Print** button.
3. Turn the printer on. The green LED turns on and blinks.

The printer calibrates the media, prints out a configuration label, and then it prints labels with the different command languages one at a time at two second intervals.

4. When the label prints out with the command language you want to use, press the **Print** button.

## Set the Command Language from the Printer Web Page

To set the command language from the printer web page, you need to turn on the printer and connect to your Ethernet network. To access the web page, see [Configure the Printer from the Printer Web Page](#) on page 26.

1. Click the **Configure > System Settings > General**.
2. Select the desired printer command language from the **Command Language** list, and then click **Save**.
3. Click the **Services** tab.
4. Click **Restart Printer**, and then click **Restart**. The printer restarts in the command language you selected.

## Set the Command Language from PrintSet 5

You can use PrintSet 5 to set the command language.

1. Click the **Configuration > System Settings > General**.
2. Select the desired printer command language from the **Command Language** list, and then click **Save**.
3. Click **Save** when you are finished.
4. Click **Printer > Apply** to apply the changes to the printer.

## About Test Labels

You can print a test label to check print quality and get configuration information, including lists of the fonts, images, and applications installed on the printer. Use one of these methods to print a test label:

- when you turn on the printer.
- when the printer is ready to print.
- with the printer configuration software.

You can also print test labels from the printer web page, which requires a network connection to a desktop PC. You need to know the printer IP address to view the printer web page. It takes around 10 seconds to acquire the IP address when you connect the printer through Ethernet. If the test label shows the IP address as 0.0.0.0, wait 10 seconds and then print another test label.

## Print a Test Label When You Turn on the Printer

You can print a test label when you first turn on the printer.

1. Make sure that the printer has media and ribbon (if necessary) installed.
2. Connect the printer to power and turn on the printer.
3. Press and hold the **Print** button until the printer calibrates the media, prints a configuration label, and then lets you select the printer command language.

## Print a Test Label When the Printer is Ready to Print

You can print a test label when the printer is sitting idle and ready to print.

1. Make sure that the printer has media and ribbon (if necessary) installed.
2. Press and hold the **Print** button until the printer advances media to the beginning of the next label. The printer will then print out a Configuration label.

# CONNECT THE PRINTER

This chapter explains how to download the Windows® printer drivers and connect the printer to your PC and an Ethernet network.

## Printer Drivers

Before you can use the printer with Microsoft® Windows® printing applications, you must install printer driver software on the PC. Drivers enable the printer to communicate with your PC and with printer software applications.

You can access the Honeywell Technical Support Downloads portal at: [honeywell.com/PSSsoftware-downloads](http://honeywell.com/PSSsoftware-downloads). Click on **Software > Printers > Printer Software and Drivers**.

**Note:** Although Windows may auto-detect the printer when you connect it to a PC through a USB port, you must install printer drivers on the PC for the printer to operate correctly.

## Install Honeywell Windows Driver

Use InterDriver to install printer driver software on your PC.

1. Access the Honeywell Technical Support Downloads portal at [honeywell.com/PSSsoftware-downloads](http://honeywell.com/PSSsoftware-downloads).
2. Download Honeywell Software Download Manager by clicking **here** in the web page. Install the Download Manager.
3. Click on the **(+)** to expand the list. Then go to **Software > Printers > Printer Software and Drivers > Printer Drivers > Windows Printer Drivers**.
4. Open the Honeywell Software Download Manager and follow the instructions to download the file.
5. Extract the driver files to a location on your PC.
6. Double-click the .exe file to install InterDriver and follow the prompts to complete the installation.

# How to Connect the Printer to Your PC

You can connect the printer to your PC using one of these cables:

- USB cable
- USB-to-Serial cable

## Connect the Printer with a USB Cable

The printer supports USB connections to a desktop PC. You do not need to set any parameters for USB communications.

**Note:** You must install InterDriver to use a USB connection to a Windows PC. For more information, see [Install Honeywell Windows Driver](#) on page 21.

1. Download and install InterDriver on your PC.
2. Connect one end of the USB cable to the USB device port on the back of the printer and when prompted during the InterDriver installation, connect the other end to your PC.

## Connect the Printer with a USB-to-Serial Cable

You can use a USB-to-serial cable to connect the USB port on the printer to the serial port on a PC.

- Connect one end of the cable to the USB device port on the back of the printer and connect the other end to your PC.

## Connect the Printer to Your Network

You can use an Ethernet or Wi-Fi connection to connect the printer to your network.

### Connect the Printer to an Ethernet Network

Use the Ethernet port to set up your printer as a network printer. The printer is set to automatically retrieve an IP address from the network (DHCP) when you turn the printer. You can use the network connection with Honeywell Printer Driver. You can also use it to send commands directly to the printer through a terminal connection (Telnet) or through FTP.

1. Turn the printer off.
2. Connect the Ethernet cable to the Ethernet port in the rear of the printer and connect the other end of the cable to your network.
3. Turn the printer on.

4. For a non-DHCP network:
  - From PrintSet 5, select **Configuration > Communications > Ethernet > IPv4** or **IPv6** and change the settings as needed.
  - From the web page, select **Configure > Communications > Ethernet > IPv4** or **IPv6** and change the settings as needed.

Setting	Default
(IPv4) IP Assignment Method	DHCP
(IPv4) IP Address	0.0.0.0
Subnet Mask	0.0.0.0
Default Router	0.0.0.0
DHCP Response	Broadcast
(IPv6) IP Assignment Method	Automatic
(IPv6) IP Address	Automatic

5. Print a test label to find the IP address of the printer. For more information, see [About Test Labels](#) on page 19.

## Connect the Printer via Wi-Fi

The printer supports wireless communications when the optional Wi-Fi module is installed.

You can configure wireless communications:

- From the printer web page
- From PrintSet 5

By default, the printer supports DHCP networks.

**Note:** *If you are not using a DHCP network, Wi-Fi settings must be configured by using Honeywell PrintSet 5 through a USB connection to the printer. Send commands through a serial connection, or use the wizards and settings menus on the printer.*

### Configure Wi-Fi Communications from the Web Page

Use this procedure to configure wireless communications from the printer web page. To access the web page, see [Configure the Printer from the Printer Web Page](#) on page 26.

**Note:** *The printer must be turned on and connected to your Wi-Fi or Ethernet network to configure the printer from the web page.*

1. Open a web browser on your PC.
2. Click the **Configure > Communications > Wireless 802.11**. The Wireless 802.11 settings page appears.

3. Change wireless settings as needed. You can also click **Default Settings** to restore all default Wireless 802.11 settings.
4. Click **Save** when you are finished.

## Configure Wi-Fi Communications from PrintSet 5

You can configure wireless communications using the Wireless Setup Wizard or from the **Configuration** settings.

To access the Wireless Setup Wizard from the main menu, click **Printer > Wireless Setup Wizard**.

To configure wireless communications from the **Configuration** settings:

1. Click **Configuration > Communications > Wireless 802.11**.
2. Change settings as needed for your wireless connection.
3. Click **Save** when you are finished.
4. Click **Printer > Apply** to apply the changes to the printer.

## Install Authentication Certificates

If you are using Wireless 802.11 security, you may need to install authentication certificates in the printer for the highest level of security.

1. Configure the printer for the correct date and time.
2. On your PC, open an FTP connection to the IP address of the printer.
3. Transfer your certificate to /home/user/certificates/public.
4. On your PC, open a Telnet session to the printer.
5. Change the directory to: **/home/user/certificates/public**.
6. Type the command: **ls -la**.
7. You should see the certificate that you transferred in step 3.
8. Use the certinstall script to install the certificate using this format:  
**<prompt> certinstall.sh <certificate name>**
9. When you receive confirmation that the certificate was installed, type the following command to make sure you see a .pem file and another soft link to the same file: **ls -la**.

**Note:** Use the printer web page or PrintSet 5 to specify the certificate .pem file to use for security.



# Configure Bluetooth Communication

You can configure Bluetooth communication:

- From the printer web page.
- From PrintSet 5.

## Configure Bluetooth Communication from the Web Page

The printer must be connected to an Ethernet or wireless network and you must know the printer IP address. To access the web page, see [Configure the Printer from the Printer Web Page](#) on page 26.

1. Click **Configure > Communications > Bluetooth**. The Bluetooth settings page appears.
2. Change Bluetooth settings as needed. You can also click **Default Settings** to restore all default Bluetooth settings.
3. Click **Save**.

## Configure Bluetooth Communication from PrintSet 5

Use the procedure to configure Bluetooth settings from PrintSet 5. You may need to configure these settings if you want to connect to a computer through Bluetooth.

1. Select **Configuration > Communications > Bluetooth**.
2. Change settings as needed for your Bluetooth device.
3. Click **Save**.

## USB Host Port

Use the USB host interface port on the printer to connect these peripheral devices:

Device	Description
Keyboard	Use a standard USB keyboard to send Fingerprint printer language commands directly to the printer or to enter information if you are running a Smart Printing application.
Barcode scanner	Use USB barcode scanners for data input with a Smart Printing application. The printer also supports other USB scanners that use a generic keyboard driver.
USB storage device	Use a USB storage device to load applications, configuration files, fonts, and images into the printer memory, or to perform firmware upgrades. You can also save configuration files to a USB storage device for upload to a printer. The USB storage device must have a single partition and be formatted as FAT16 or FAT32.

You can also connect a peripheral device through the USB-to-Serial cable.

## Connect a USB Device

You can use the USB host interface port on the printer to connect keyboards, barcode scanners, or a USB storage device.

1. If you are connecting a USB storage device, make sure the device has a single partition and is formatted as FAT16 or FAT32.
2. Connect the device to the USB host port.

## Configure the Printer

You can configure your printer:

- from the printer web page.
- with PrintSet 5.

You can download Honeywell applications to extend the capabilities of the printer. You may need to purchase a license to run some applications. To learn more about licenses and other Honeywell software solutions, go to [sps.honeywell.com](https://sps.honeywell.com) > **Software** > **Productivity**.

Support for Honeywell Safety and Productivity Solutions products is available online through the Technical Support Portal.

## Configure the Printer from the Printer Web Page

You can configure most network settings from the printer web page.

1. Start a web browser on your PC.
2. In the address field, type the IP address of your printer and press **Enter**. The printer web page appears.

**Note:** *If you do not know the IP address of your printer, you can print a configuration label. For more information, see [About Test Labels](#) on page 19.*

3. Click **Login**.
4. Type your **Username** and **Password** in the entry fields, and then click **Login**. The default username is *itadmin*, and the default password is *pass*.
5. Click **Configure**. The Configuration Summary page appears.
6. To see a list of printer settings, click **Configuration Summary**.

To configure printer settings, use the links in the navigation pane:

- For serial, Ethernet, Bluetooth or Wireless 802.11 settings, click **Communications**.

- For media or print quality settings, click **Printing**.
  - For display, audio, service, and general settings, or maintenance alert message triggers, click **System Settings**.
  - For network-related settings (such as DNS, WINS, Net1), for web and email server information, or if you are using a network management application, click **Network Services**.
7. Make any changes to the settings you want to configure.
  8. To save your changes, click **Save**.
  9. To reset all parameters on the page to the default settings, click **Default Settings**.

## Configure the Printer with PrintSet 5

You can use PrintSet 5 to change configuration settings on your printer. You can download PrintSet 5 from the Honeywell Technical Support Downloads portal ([honeywell.com/PSSsoftware-downloads](http://honeywell.com/PSSsoftware-downloads)).

To configure the printer with PrintSet 5, use the **Configuration** settings.

- When you are finished changing the **Configuration** settings, click **Save**.
- To apply the configuration changes to the printer, click **Printer > Apply**.

## Upgrade the Firmware

Check for periodic updates to the printer firmware.

### Download the Printer Firmware Update

Before you can upgrade the printer firmware, you need to download the upgrade file from the Honeywell website.

The latest version of the firmware is available from the Honeywell Technical Support Downloads portal ([honeywell.com/PSSsoftware-downloads](http://honeywell.com/PSSsoftware-downloads)). Go to **Software > Printers > Desktop > PC42E-T > Current > Firmware**).

## Upgrade Firmware from the Printer Web Page

You can upgrade the printer firmware from the printer web page. To configure the printer from the web page, the printer must be turned on and connected to your Wi-Fi or Ethernet network. To access the web page, see [Configure the Printer from the Printer Web Page](#) on page 26.

1. Download the printer firmware from the Honeywell website. See [Download the Printer Firmware Update](#) on page 27.
2. Click the **Services > Firmware Upgrade**.

The Firmware Upgrade screen is displayed showing the current firmware version.

3. Click **Browse** to locate the upgrade file, select the file, and then click **Open**.
4. Click **Upgrade**.

The printer web page shows that it is upgrading the firmware on your printer.

## Upgrade Firmware from PrintSet 5

You can upgrade the printer firmware from the PrintSet 5 Firmware Update Wizard.

1. Download the printer firmware from the Honeywell website. See [Download the Printer Firmware Update](#) on page 27.
2. From the main menu, click **Printer > Firmware Update Wizard**.
3. Follow the steps of the wizard to complete the upgrade.

## Upgrade Firmware from a USB Storage Device

Use a USB storage device to upgrade the printer firmware.

1. Make sure the USB storage device has a single partition and is formatted as FAT16 or FAT32.
2. Download the printer firmware from the Honeywell website. See [Download the Printer Firmware Update](#) on page 27.
3. Copy the firmware upgrade file (typically a .bin format) to the root of a USB storage device.
4. Turn off the printer.
5. Insert the USB storage device into one of the USB host ports.
6. Turn on the printer.

As the firmware upgrade file is loaded into the printer, the status LED blinks orange. This process may take several minutes.

When the printer status LED turns solid green, the printer is ready to use.

# TROUBLESHOOT AND MAINTAIN THE PRINTER

## Locate the Printer Configuration and Serial Numbers

You can also find the printer configuration and serial numbers on the product label located on the bottom of the printer.

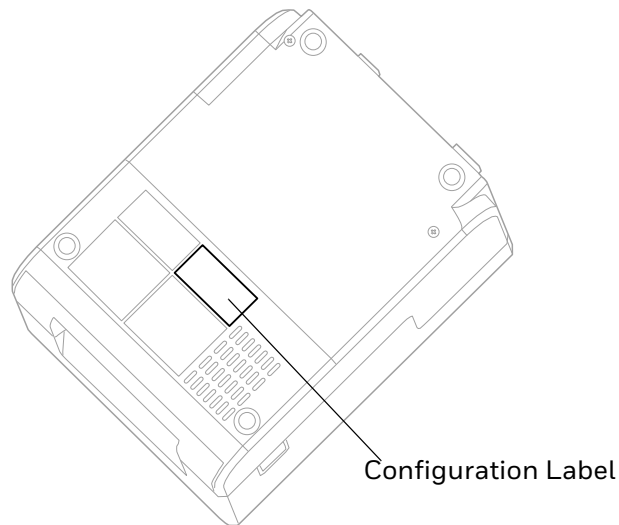

## Printer Problems and Possible Solutions

Use this section to find possible solutions to printer problems.

Problem	Possible Solution
The status LED is off, but the power is on.	Make sure the connectors on the power supply are securely plugged into the printer and an AC outlet.
The status LED is green, but the printer is not feeding media.	Make sure the correct type of interface cable is securely plugged into both the printer and computer.

<b>Problem</b>	<b>Possible Solution</b>
Only partial labels are being printed.	Try these possible solutions: Make sure that the print and ribbon mechanism is fully locked. Open the printer and lower the printhead completely until both latches click into place. Check to see if a label is caught on the printhead. If you find a caught label, remove the label and clean the printhead. For help, see <a href="#">Clean the Printhead</a> on page 31.
The print quality is poor.	Try these possible solutions: Clean the printhead. For help, see <a href="#">Clean the Printhead</a> on page 31. Make sure the ribbon is compatible with the media. Make sure the darkness setting is correct for the media and ribbon combination.
The printer seems to be working but nothing prints.	For direct thermal printing, try these solutions: Make sure that the heat-sensitive side of the media is facing the printhead. Verify that the media is direct thermal media by firmly running your fingernail on the surface of the media. If you see a black line, the media is direct thermal.
The printing stops and status LED is red.	Try these possible solutions: Use PrintSet 5 to check the printer error status. There may be a media jam. Open the printer and check for stuck labels or ripped perforations. If a "Printhead Lifted" error is reported and the printhead is closed, make sure the round white sticker is present on the right side of the print and ribbon mechanism.
The printer continues to print or feed when it should stop printing	Check to see if a stuck label is blocking the label gap sensor. Open the top cover, remove the label, and clean the printhead. For help, see <a href="#">Clean the Printhead</a> on page 31.

## How to Restore Default Settings

If you need to restore factory defaults at any time, you can use:

- the **Print** button.
- the printer web page.
- PrintSet 5.

## Restore Default Settings with the Print Button

The easiest way to reset the printer to the factory default settings is with the Print button.

1. Turn off the printer.
2. Press in on the cover latches on both sides of the printer and open the cover.
3. Press in on the top of both locking tabs to open the print and ribbon mechanism.

4. Turn the printer on.
5. When the status LED starts blinking green, press and hold the **Print** button until the status LED turns off.
6. Make sure the media is loaded correctly.
7. Close the print and ribbon mechanism.
8. Close the cover.

## Restore Default Settings from the Printer Web Page

If the printer is connected to an Ethernet network, you can restore default settings from the printer web page. To access the web page, see [Configure the Printer from the Printer Web Page](#) on page 26.

1. Click **Services > Restore Defaults**.
2. Select the settings you want to restore:
  - Check the **Network settings** check box to restore defaults for all network connections, such as IP address and network name.
  - Check the **User-Installed Files** check box to erase all files you uploaded to the printer memory.
  - Check the **System Settings** check box to restore defaults for system settings, such as media width.
3. Click **Restore**.
4. Click **Yes** to continue. The printer restarts and the settings you selected are restored to default values.

## Restore Default Settings with PrintSet 5

If you have PrintSet 5 installed on your PC, you can use it to restore the default settings on your printer.

- Use the Factory Default Wizard.

## Clean the Printhead

Cleaning the printhead on a regular basis is important for the life of the printhead and for the best print quality. You should clean the printhead each time you replace the media. Follow this procedure to clean the printhead using the cleaning card. If you need to clean additional residue from the platen roller or tear bar, use a cotton swab moistened with isopropyl alcohol.



**Caution: Never use hard or sharp tools to peel away stuck labels or other material. The printhead is delicate and can easily be damaged.**

1. Turn the printer off and disconnect the printer from power.
2. Open the printer, open the print mechanism, and remove the media and ribbon (if installed).
3. Insert most of the cleaning card under the printhead, and then lower the print mechanism.
4. Pull out the cleaning card and raise the printhead.
5. Wait for approximately 30 seconds to allow the cleaning fluid to dissolve the residue.
6. Print a test label to check for print quality. For help, see [Print a Test Label When the Printer is Ready to Print](#) on page 20.
7. Repeat Steps 3 through 5 if necessary.
8. If necessary, clean residue from the platen roller or tear bar with a cotton swab moistened with isopropyl alcohol.
9. Once the parts are dry, replace the media (and ribbon) in the printer.
10. Close the printer, reconnect power, and turn on the printer.

## Replace the Printhead

You need to replace the printhead periodically when it wears out due to the rapid heating and cooling process used during printing. How often you need to replace the printhead depends on factors such as what type of images you print, the type of media or ribbon you use, the amount of energy to the printhead, the print speed, and the ambient temperature of the room you print in. The firmware detects the new printhead when you restart the printer.

1. Turn off the printer and disconnect the power cord.
2. Press in on the cover latches on both sides of the printer and open the cover.
3. Press in both locking buttons to open the print and ribbon mechanism.
4. For thermal transfer printing, remove the ribbon.



5. Push the tabs at each end of the printhead over the tab holders on the print and ribbon mechanism.

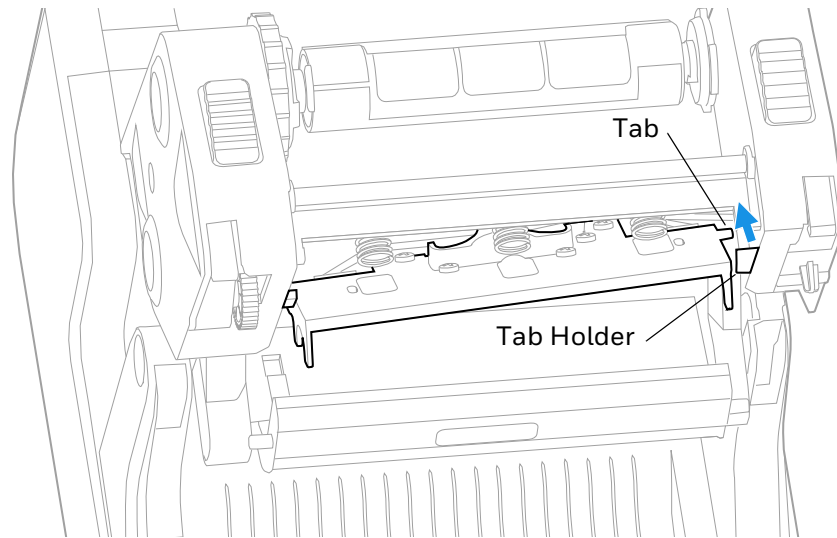

6. Pull the printhead away from the printer and complete the following steps:
  - a. Disconnect the cables at each end of the printhead.
  - b. Use a Phillips screwdriver to remove the screw attached to the grounding wire.

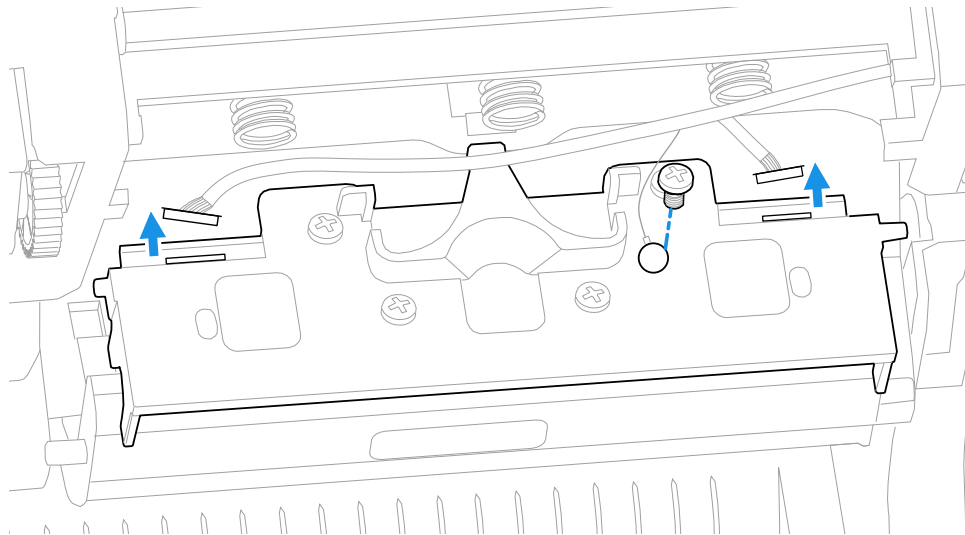

7. Remove the printhead from the printer.
8. Install the new printhead, starting with the following steps:
  - a. Connect the cables at each end of the printhead.
  - b. Use a Phillips screwdriver to secure the grounding wire and screw.



**Warning: Do not touch the printhead surface area.**

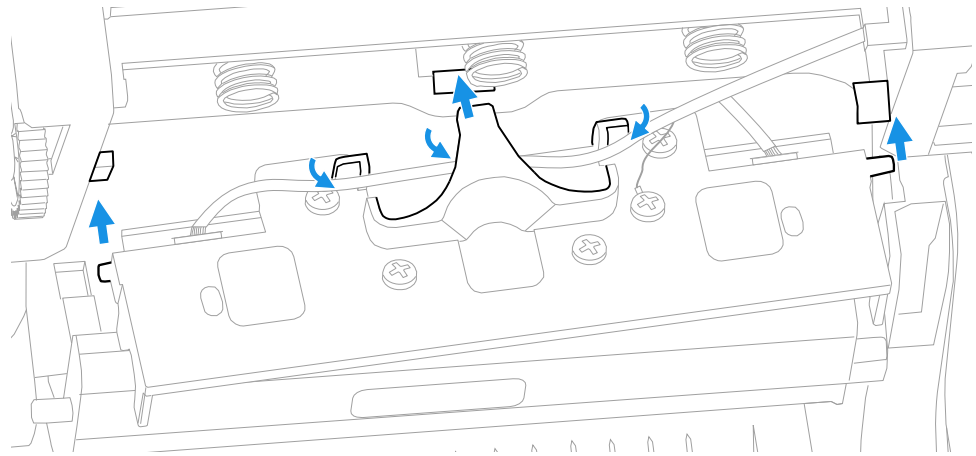

9. Ensure that the cable attached to the printhead is secured by the cable holders on the rear of the printhead.
10. Slide the tab at the rear of the printhead into the hole behind the middle spring on the print and ribbon mechanism.
11. Push the tabs at each end of the printhead over the holders on the print and ribbon mechanism.
12. For thermal transfer printing, install the ribbon.
13. Close the print and ribbon mechanism and the printer cover.

## Clean the Platen Roller

Follow this procedure to remove, clean, and replace the platen roller as part of standard maintenance for the printer. You should check the platen roller for debris each time you load media and clean it if dirty.



**Caution: Never use hard or sharp tools to peel away stuck labels or other material. The platen roller is delicate and can easily be damaged.**

1. Turn the printer off and disconnect the power cord.
2. Press in on the cover latches on both sides of the printer and open the cover.
3. Press in both locking buttons to open the print and ribbon mechanism.
4. Remove the installed media (and ribbon).

5. Press in and then roll forward each of the latches at the ends of the platen roller.

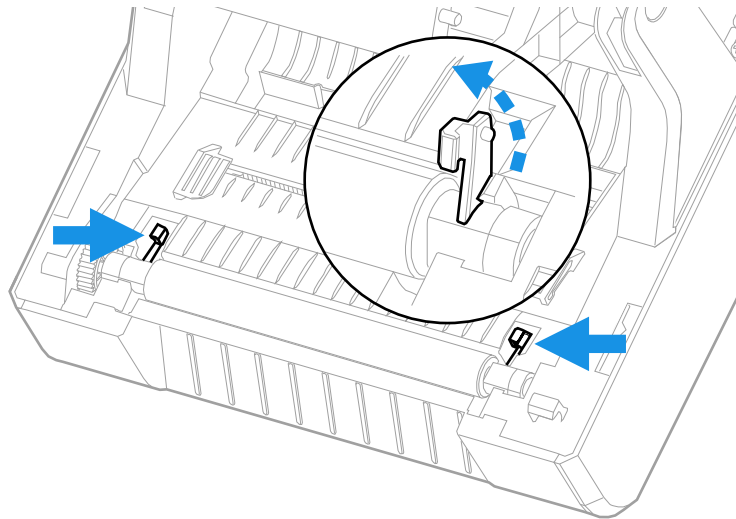

6. Pull up on the platen roller to remove it from the printer.

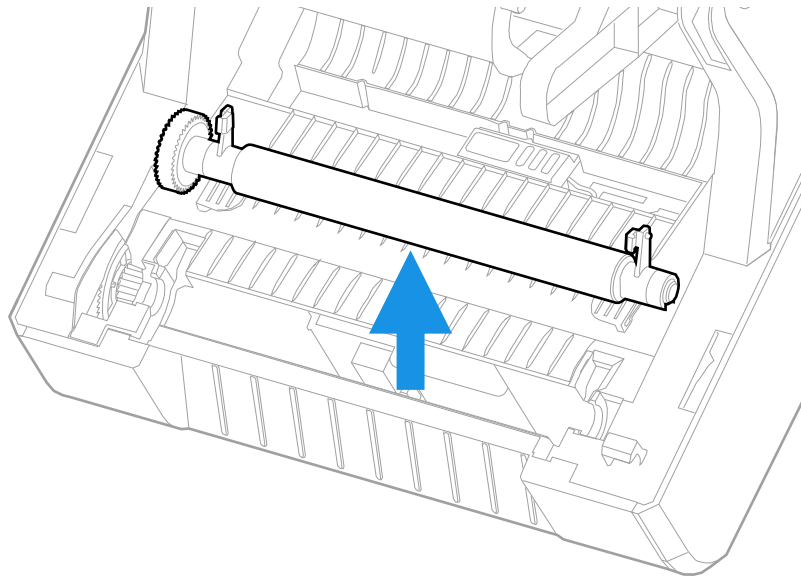

7. Remove any adhesive residue from the roller with a cotton swab moistened with isopropyl alcohol.
8. Reverse Steps 5 and 6 to install the roller.
9. Lower the print and ribbon mechanism and press down on each side until the locking tabs snap into place.
10. Close the cover.

## Clean the Interior of the Printer

To keep the interior of the printer clean:

- Make sure the media path is clean.
- Make sure sensor mylar covers are free of fingerprints, oil, dirt, and dust.

## Clean the Exterior of the Printer

Make sure to keep the exterior of the printer clean. Maintaining a clean exterior will reduce the risk of dust or foreign particles reaching the inside of the printer and affecting printer functionality.

Use a soft cloth moistened with water or a mild detergent when cleaning the printer exterior. Make sure to keep the surface surrounding the printer clean as well.

## SPECIFICATIONS

This appendix contains specifications for the printer.

## Specifications and Resources

1. Go to [sps.honeywell.com](https://sps.honeywell.com).
2. Type PC42E-T in the search box and then press **Enter**.
3. Click on the product link in the search results.
4. Select one of the following tabs:
  - **Specifications**  
View Printer features, Software, Hardware information, and environmental specifications.
  - **Resources or Documents**  
View and download available product documentation. For example, Data Sheet, Accessory Guide, Quick Start Guide, User Guide, Regulatory Information, and other product documentation.

## Media Specifications

Parameter	Specification
Media types	Continuous, die-cut, notch, black mark, fan-fold
Media width	25.4 mm (1 in) to 114 mm (4.48 in)
Media length (min.)	9.6 mm (0.38 in)
Maximum print width	108 mm (4.25 in)
Maximum print length	4826 mm (190 in) for 203dpi, 2159 mm (85 in) for 300dpi
Media thickness	0.076 mm (3.0 mil) to 0.19 mm (7.48 mil)
Media roll diameter (max.)	127 mm (5 in)
Media core size	25.4 mm (1 in) to 38 mm (1.5 in)

<b>Parameter</b>	<b>Specification</b>
Ribbon type	Wax, mid-range, resin
Ribbon direction	Coated out
Ribbon width	25.4 mm (1 in) to 110 mm (4.3 in)
Ribbon core size	12.7 mm (0.5 in) or 25.4 mm (1 in)

## Print Sensors

- Black Mark Sensors
- Head Lift Sensor
- Label Gap Sensor
- Ribbon Low Sensor

## Fonts

### Resident Fonts

- Andale Mono
- Andale Mono Bold
- Century Schoolbook Roman
- CG Times
- CG Times Bold
- CG Triumvirate Condensed Bold
- Dutch 801 Roman
- Honeywell Sans TT Bold
- Letter Gothic
- MHeiGB18030C-Medium
- Monospace 821
- Monospace 821 Bold
- OCR A
- OCR B
- Univers
- Univers Bold
- Univers Condensed Bold
- Univers Extra Condensed

## Downloadable Fonts

For broader language and character support, any Unicode TrueType or TrueType-based OpenType font may be downloaded. Fonts from Monotype Imaging are recommended to address global languages. The fonts below have been tested and are available for purchase and download at [www.fonts.com](http://www.fonts.com).

WorldType Collection fonts support all global languages whereas the other fonts listed support specific languages.

- Angsana New Regular
- Helvetica World
- HYGothic-Medium
- MSung HK Medium
- MSung PRC Medium
- NarkisClassicMF
- TBMinPro-Light
- WorldType Collection J
- WorldType Collection K
- WorldType Collection S
- WorldType Collection T

## Supported Font Types

- TrueType
- OpenType
- Bitmap

## Printed Barcode Symbologies

### 1D Barcode Symbologies

- Codabar
- Code 11
- Code 39
- Code 93
- Code 128
- DUN-14/16
- EAN
  - EAN-8

- EAN-8 Composite with CC-A or CC-B
- EAN-13
- EAN-13 Composite with CC-A or CC-B
- EAN128
- EAN128 subset A
- EAN128 subset B
- EAN128 subset C
- EAN.UCC 128 Composite with CC-A or CC-B
- EAN.UCC 128 Composite with CC-C
- HIBC 39
- HIBC 128
- Industrial 2 of 5
- Interleaved 2 of 5
- ISBT-128
- Matrix 2 of 5
- Straight 2 of 5
- UPC
  - UPC-5 digits Add-On Code
  - UPC-D1
  - UPC-D2
  - UPC-D3
  - UPC-D4
  - UPC-D5
  - UPC Shipping Container Code

## 2D Barcode Symbolologies

- Aztec
- Code 16K
- Code 49
- Data Matrix
- DotCode
- Grid Matrix
- MaxiCode
- MicroPDF417



- MSI (modified Plessey)
- PDF417
- Planet Code
- Plessey Code
- Postnet
- QR Code
- RSS-14
- USPS 4-State Customer barcode

## Graphic File Types

- PCX
- PNG
- GIF
- BMP



# DEFAULT SETTINGS

This appendix contains all of the default settings for the printer.

## Default Configuration

Use this appendix to view the default settings on the printer. If you restore the printer to factory default settings, it will use the values listed here. The order of the settings reflects the organization of the printer web page.

## Ethernet Settings

This section describes the Ethernet IPv4 settings. To view these settings:

- From the printer web page, click **Configure** > **Communications** > **Ethernet**.
- From PrintSet 5, click **Configuration** > **Communications** > **Ethernet**.

### IPv4

Setting	Description	Default
IP Assignment Method	Specifies how the printer obtains an IP address.	DHCP
IP Address	Specifies the unique network-level address that is assigned to each device in a TCP/IP network (IPv4).	0.0.0.0
Subnet Mask	Specifies a number that defines the range of IP addresses that can be used in a TCP/IP network.	0.0.0.0
Default Router	Specifies the IP address of a router that is used when a device sends a packet to another subnet or to an unknown destination.	0.0.0.0
DHCP Response	Specifies if the printer receives DHCP responses by broadcast or unicast.	Broadcast

## IPv6

Setting	Description	Default
IP Assignment Method	Specifies how the printer obtains an IP address (for IPv6 networks).	Automatic
IP Address	Specifies the unique network-level address that is assigned to each device in a TCP/IP network (IPv6).	Automatic

## 802.1x Authentication

Setting	Description	Default
802.1x Security	Enable or disable 802.1x Security.	Disable
EAP Type	Selects the protocol that the radio uses to verify its identity and ensures that it is authorized to communicate on the network.	PEAPv0-MSCHAPv2
Username	User name for Ethernet 802.1x Authentication.	None
Password	Password for PEAP authentication or private-key password for TLS.	None
CA Certificate	Sets the name of the Certificate Authority (CA) that verifies the server certificate. The CA should be the same that was used to sign the certificate.	None
Client Certificate	Sets the name of the client certificate the printer uses to authenticate to the network using EAP-TLS. Maximum length is 128 characters.	None
Private Key	Sets the full path to the private key file the printer uses for EAP-TLS. Maximum length is 128 characters. For a pfx file, the client certificate should not be specified.	None

## Media Settings

This section describes media settings for the printer. To view these settings:

- From the printer web page, click **Configure > Printing > Media**.
- From PrintSet 5, click **Configuration > Printing > Media**.

Setting	Description	Default
Media Type	Selects the type of media that is loaded in the printer.	Media with Gaps
Print Method	Selects the method of printing that the printer is using.	Thermal Transfer

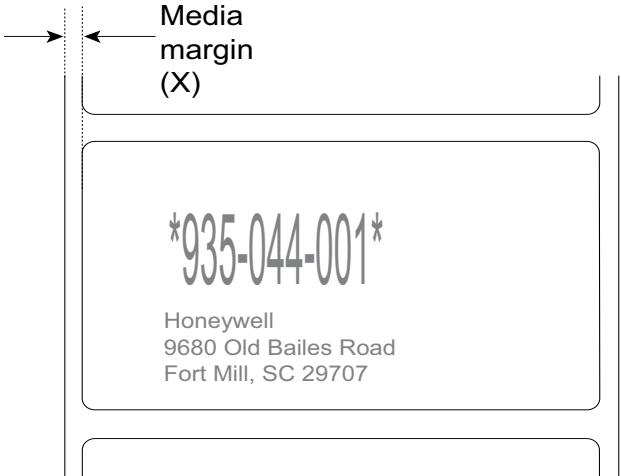
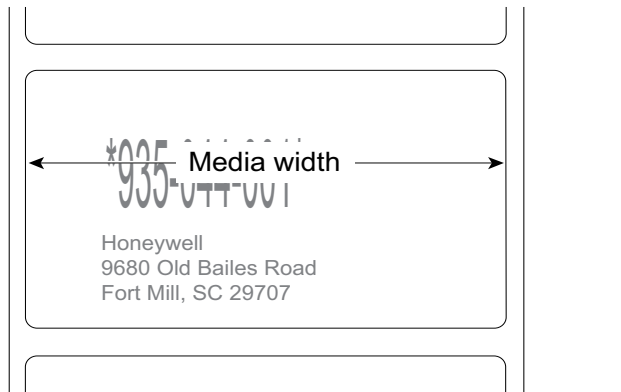
Setting	Description	Default
Media Margin (X)	<p>Sets the width of the margin from the left edge of the label along the printhead to the edge of the printable area. Unit of measurement is defined in the Unit of Measurement parameter.</p> 	Variable
Media Width	<p>Sets the width of the printable area measured from the media margin (X) across the printhead. Unit of measurement is defined in the Unit of Measure parameter.</p> 	Variable

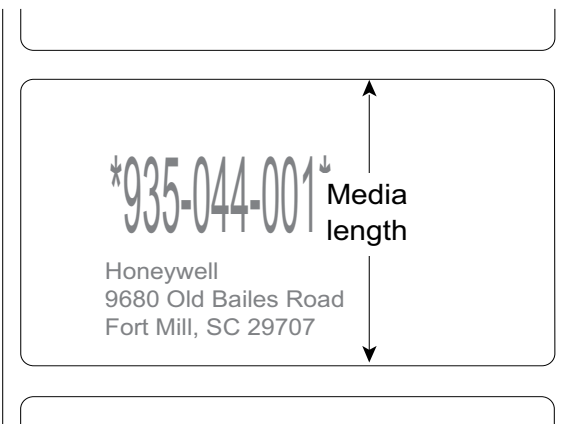
Setting	Description	Default
Media Length	<p>Sets the length of the printable area measured from one edge of the label to the edge that is closest to the printhead. Unit of measurement is defined in the Unit of Measurement parameter.</p> 	Variable
Print Mode	Selects the printer media mode: tear off, peel-off, cutter, or rewind.	Tear off
Clip Default	<p>Determines if the printer prints items outside the printable area of the label.</p> <p>When this is set to Off, the printer returns an error if any part of a barcode label cannot be printed because that part extends beyond the printable area.</p> <p>When this is set to On, the printer prints all bar ode labels, but may also print unreadable, incomplete labels.</p>	Off
Label Top Adjust	Sets the length of media the printer feeds (positive value) or retracts (negative value) before printing a label. Unit of measurement is defined in the Unit of Measure parameter. Range is -9999 to +9999.	0 dots
Label Reset Adjust	Sets the length of media the printer feeds (positive value) or retracts (negative value) after printing a label. Unit of measurement is defined in the Unit of Measure parameter. Range is -9999 to +9999.	0 dots
Media Calibration Mode	<p>Selects the mode the printer uses to calibrate media.</p> <p>Use Fast calibration (ECO mode) to conserve media. The printer media calibration process will use a minimal length of labels.</p> <p>Use Slow calibration if the printer has trouble identifying gaps or marks in media. The printer media calibration process will use the length of multiple labels.</p>	Slow
Length (Slow Mode)	If Media Calibration Mode is set to Slow, the printer prints the media length plus 10 mm. This value sets an additional amount of media to be printed. Unit of measurement is defined in the Unit of Measurement parameter.	0 dots

Setting	Description	Default
Power Up Action	Sets the action when you turn the printer on: No Action Formfeed - The printer feeds one label. Testfeed - The printer prints two configuration labels as it calibrates the media sensors.	No Action
Head Down Action	Sets the action when you close the print mechanism after opening it: No Action Formfeed - The printer feeds one label. Testfeed - The printer prints two configuration labels as it calibrates the media sensors.	Formfeed
Hold Feed Button Action	Sets the action when you press and hold the Print button for more than 2 seconds: Test feed -The printer prints two configuration labels as it calibrates the media sensors. Smart Calibration - Detects media type (gap, black mark, or continuous, detects printing method (ribbon or no-ribbon), and calibrates media length.	Smart Calibration
Label Counter	Specifies a label counter (from 1 to 49) that SNMP uses to report media counts.	0 (off)
Media Out Immediate Stop	Immediately stops feeding media when no media is detected.	Disable

## Print Quality Settings

This section describes print quality settings. To view these settings:

- From the printer web page, click **Configure** > **Printing** > **Print Quality**.
- From PrintSet 5, click **Configuration** > **Printing** > **Print Quality**.

Setting	Description	Default
Print Speed	Sets how fast the printer prints labels. The unit of measure is defined in the Unit of Measure parameter.	100
Darkness	Sets the image darkness for media and ribbon. Adjust this parameter with the Media Sensitivity parameter. Range is 1 to 100.	Variable
Media Sensitivity	Sets the level of sensitivity of the media to the printhead heat for media and ribbon.	High
Contrast	Adjusts the blackness of the printing on the label in 2% increments from -10% to +10%.	+0%
Label Rotation	Rotate the label in 0 (no rotation), 90, 180, and 270 degrees in clockwise.	0°

## General System Settings

This section describes general system settings. To view these settings:

- From the printer web page, click **Configure** > **System Settings** > **General**.

- From PrintSet 5, click **Configuration > System Settings > General**.

General System Setting	Description	Default
System Name	Sets the network identification name (WINS name) of the printer.	Printer model number and serial number
System Location	Sets the location of the printer.	Empty string
System Contact	Sets the name of the printer administrator.	Empty string
XML Response Mode	Determines if the printer provides XML responses to printing requests (over Telnet and HTTP).	False
Display Language	Selects the language the printer uses to display text on the screen.	English
Display Language (Web Page)	Selects the language the printer uses to display text on the web page.	English
Keyboard Input	Selects the language of the external keyboard that is connected to the printer.	U.S./U.K.
Time	Sets the current time.	System time
Date	Sets the current date.	System date
Command Language	Sets the printer command language. If changed, requires restart.	Autosense
Unit of Measure	Selects the unit of measure that is used to define several printing parameters.	Dots
Zero with Slash	Determines how the zero character is printed and displayed on the screen. Disable (0) or Enable (Ø).	Disable
Time Zone	Sets the time zone.	(UTC 00:00) Universal Time
DST Adjust	Determines if Daylight Saving Time is automatically adjusted.	Disable
Legacy Mode	Enable or Disable Legacy EasyCoder PF/PM/PX Comparability Mode.	Disable

## Manage I/O Settings

This section describes system I/O settings for the printer. To view these settings:

- From the printer web page, click **Configure > System Settings > Manage I/O**.
- From PrintSet 5, click **Configuration > System Settings > Manage I/O**.

Setting	Description	Default
Ethernet	Determines if the printer is allowed to communicate using Ethernet communications.	Enable
Wireless 802.11	Determines if the printer is allowed to communicate using its 802.11 radio. Supported only if the optional Wi-Fi module is installed.	Enable



Setting	Description	Default
Bluetooth	Determines if the printer is allowed to communicate using Bluetooth. Supported only if the optional Bluetooth module is installed.	Enable

## Manage Services Settings

This section lists the system services you can manage from the printer. You will only see **Manage Services** from the menus if you have an Ethernet module installed in the printer. To view these services:

- From the printer web page, click **Configure > System Settings > Manage Services**.
- From PrintSet 5, click **Configuration > System Settings > Manage Services**.

Setting	Description	Default
Web Server	Determines if the web server is enabled in the printer.	Enable
FTP	Determines if the printer can use FTP (File Transfer Protocol).	Disable
Net1	Determines if the printer can use Telnet to communicate with Direct Protocol (Fingerprint).	Enable
LPR	Determines if the printer can use the LPR (Line Printer Server) daemon.	Enable
Telnet	Determines if the printer can use Telnet to communicate with another device.	Disable
SSH	Determines if the printer can use Secure Socket Handling (SSH).	Disable
XML	Determines if the printer can use XML printing.	Enable
Time Server	Determines if the printer uses the Network Time Protocol (NTP) to synchronize its time with a network time server. The default Server Address is <b>ntp0.cornell.edu</b> , and the default Port Number is <b>123</b> .	Disable
Device Management	Determines if the printer can use 9300 TCP/IP port to communicate with HCD.	Enable
Connectivity Agent	Determines if the printer can communicate with Honeywell Cloud on port 10000.	Disable

## DNS Network Services

This section describes the DNS settings for the printer. To view these settings:

- From the printer web page, click **Configure > Network Settings > DNS**.

- From PrintSet 5, click **Configuration** > **Network Settings** > **DNS**.

Setting	Description	Default
Primary DNS Server	Sets the IP address of the primary server to which the printer sends DNS requests. The DNS server retains IP addresses and routing information for the TCP/IP network.	0.0.0.0
Secondary DNS Server	Sets the IP address of the secondary server to which the printer sends DNS requests. The DNS server retains IP addresses and routing information for the TCP/IP network.	0.0.0.0

## Net1 Network Services

This section describes the Net1 settings for the printer. To view these settings:

- From the printer web page, click **Configure** > **Network Settings** > **Net1**.
- From PrintSet 5, click **Configuration** > **Network Settings** > **Net1**.

Setting	Description	Default
Queue	Selects how the printer handles multiple Net1 connections.	On
Port Number	Sets the port number that defines the Net1 TCP port. The range is from 0 to 65535.	9100
New Line Character	Defines the characters that the printer echoes to the host to indicate that it has moved to a new line.	CR/LF
Timeout	Sets the timeout value in seconds that printer uses to check the existing connection when the connection is terminated from other end. Range is 60 to 700 seconds.	700
Secure Communication	Determines if TLS encryption is used for data communication.	Disable

## Email Server

To view these settings:

- From the printer web page, click **Configure** > **Network Services** > **Email Server**.
- From PrintSet 5, click **Configuration** > **Network Services** > **Email Server**.

Email Server	Description	Default
Mode	Selects the mode the printer uses to communicate with the email server.	Manual
Port Number	Sets the port number the printer uses to communicate with email server. Range is 1 to 65535.	25
Server Address	Sets the IP address of the email server	0.0.0.0

Email Server	Description	Default
From Address	Sets the email address of the person who will receive the alert messages.	-
To Address	Sets the email address that appears as the sender of the alert messages.	-
Email Password	Sets the password the printer uses to communicate with SMTP SSL service.	-

## WINS Network Services

This section describes the WINS settings for the printer. To view these settings:

- From the printer web page, click **Configure > Network Settings > WINS**.
- From PrintSet 5, click **Configuration > Network Settings > WINS**.

Setting	Description	Default
Primary WINS Server	Sets the IP address of the primary server to which the printer sends WINS requests. The WINS server retains IP addresses and routing information for the TCP/IP network.	0.0.0.0
Secondary WINS Server	Sets the IP address of the secondary server to which the printer sends WINS requests. The WINS server retains IP addresses and routing information for the TCP/IP network.	0.0.0.0

## Web Server Network Services

This section describes the Web Server settings for the printer. To view these settings:

- From the printer web page, click **Configure > Network Settings > Web Server**.
- From PrintSet 5, click **Configuration > Network Settings > Web Server**.

Setting	Description	Default
Image Buffer	Determines if the image buffer appears in the printer web page.	Enable
Web Server Protocol	Selects web server protocol. Auto (HTTP+HTTPS) or HTTPS only.	HTTPS only
Webpage Customization	Determine whether the web server will run a customized web page.	Disable

## Connectivity Agent

To view these settings:

- From the printer web page, click **Configure > Network Services > Connectivity Agent**.

- From PrintSet 5, click **Configuration > Network Services > Connectivity Agent**.

<b>Connectivity Agent</b>	<b>Description</b>	<b>Default</b>
Server Address	Sets the IP address of the connectivity server.	0.0.0.0
Server Hostname	Sets the Hostname of the connectivity server.	hostname.dns.com
Port Number	Sets the port number printer uses to communicate with the connectivity server.	10000
Telemetry Frequency (Seconds)	Sets the telemetry frequency (in seconds) of the connectivity agent at which telemetry data has to be sent to the connectivity server.	2160
Unique ID	Sets the unique ID from the connectivity server.	-
Fingerprint Validation	Sets the fingerprint ID from the connectivity server.	-
Update Request Interval (Minutes)	Sets the interval (in minutes) to send the auto update request to connectivity server.	60
Buzzer	Sets the buzzer to beep while downloading/updating the file.	Disable

## XML Printing

To view these settings:

- From the printer web page, click **Configure > Network Services > XML Printing**.
- From PrintSet 5, click **Configuration > Network Services > XML Printing**.

<b>Time Server</b>	<b>Description</b>	<b>Default</b>
Port Number	Sets the port number that defines the TCP port of XML printing. Range is 1024 to 65535.	9200
Secure Communication	Determines if TLS encryption is used for data communication.	Disable

## Device Management

To view these settings:

- From the printer web page, click **Configure > Network Services > Device Management**.
- From PrintSet 5, click **Configuration > Network Services > Device Management**.

<b>Time Server</b>	<b>Description</b>	<b>Default</b>
Secure Communication	Determines if TLS encryption is used for data communication.	Disable

# PRINT LABELS WITH INPRINT

## The INPrint Page

The INPrint page features sample web forms you can use to print single labels if you are using the Fingerprint or Direct Protocol Language on your printer. Select a web form from the lists and enter information in the fields for that label. You can then preview and print the label.

The printer firmware includes several predefined label formats. You can also copy your own label formats to the printer and print them from the INPrint page.

## Print INPrint Labels

If the printer is connected to an Ethernet or Wi-Fi network, you can print labels by entering information in a web form. Access the web forms through the printer web page.

1. Open a browser window on your PC.
2. In the location or address bar, type the printer IP address and press **Enter**. The printer web page appears.
3. Click the **INPrint** tab.
4. Select the web form you want to print:
  - If you created the web form yourself, click **Customer Downloaded** and then select the web form in the list.
  - To use one of the Honeywell resident web forms, click **Resident** and then select the web form in the list.
5. Type information in the web form as needed.

To preview the label on screen, click **Preview**. To print the label, click **Print**.



# INSTALLING ACCESSORIES

## Cutter Module

The cutter module allows you to cut non-adhesive media into individual labels.

## Out of the Box

You will find the following item in the shipping box: cutter module.

## Installation



**Caution: Before you begin, turn off the printer and disconnect the power cord and communication cables.**

1. Turn the printer off and disconnect the power cord.
2. Press in on the cover latches on both sides of the printer and open the cover.
3. Press in both locking buttons to open the print and ribbon mechanism.

4. Remove the tear bar by pushing it upwards.

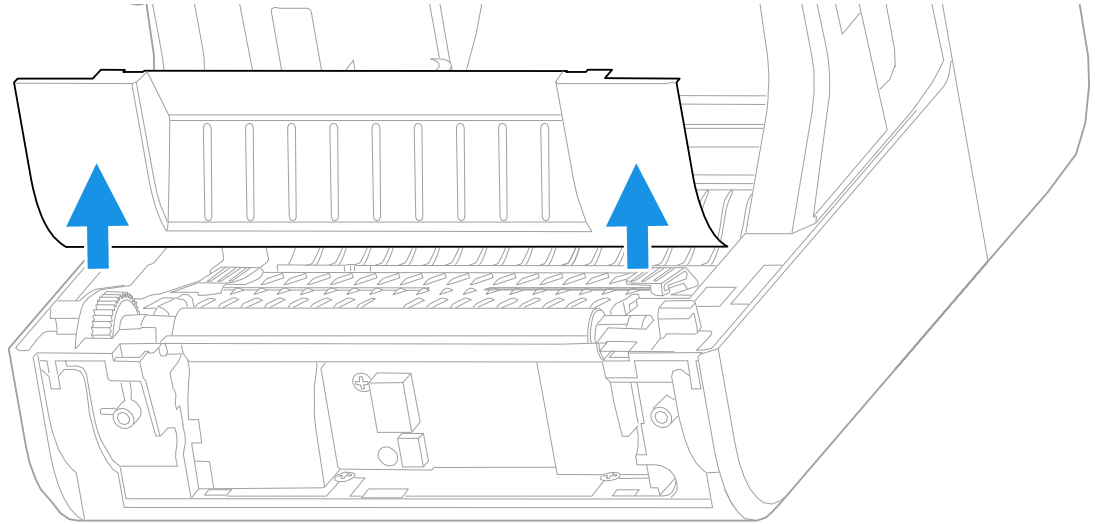

5. Insert the cable on the cutter module into connector on the printer and slide the tabs on the module into the slots on the printer.

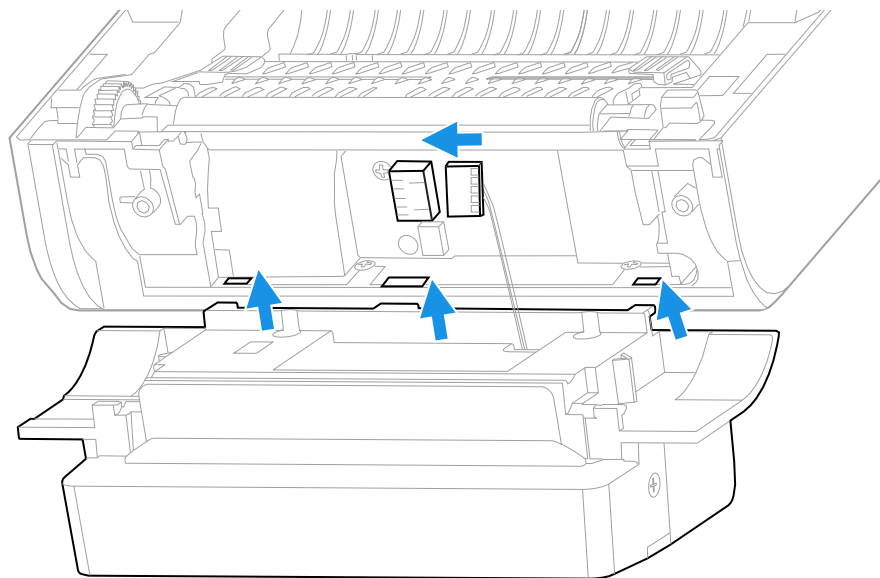



6. Lift the cutter module into the printer.

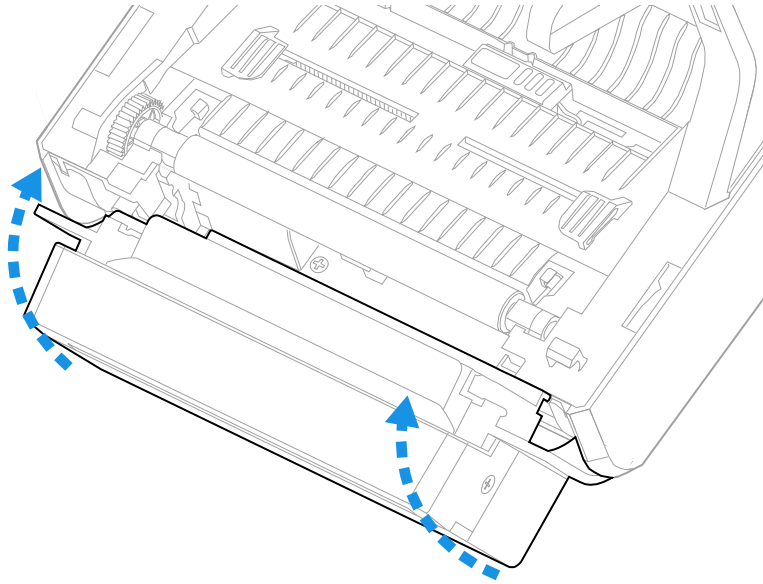

7. Push the cutter module down to secure it on the printer.

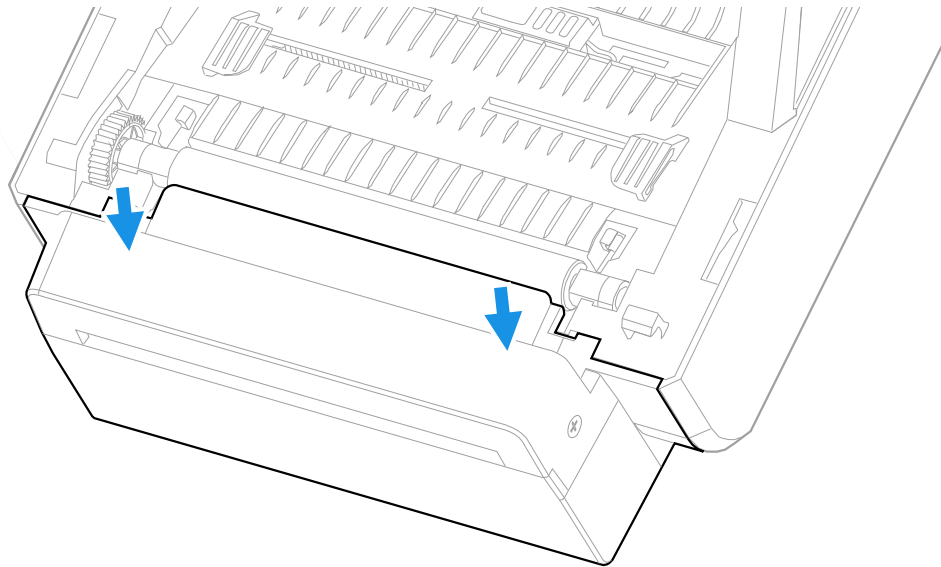

8. Load media under the bar in the back of the cutter module and out of the opening at the front of the module.

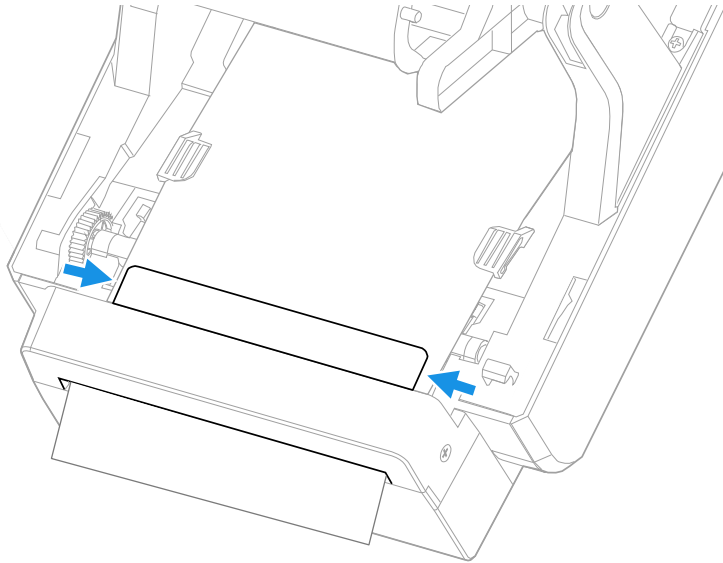

9. Close the print and ribbon mechanism and the printer cover.

## Peel-Off Module

The peel-off module allows you to remove labels from the liner of self-adhesive label stock as part of the printing process.

## Out of the Box

You will find the following item in the shipping box:

- Peel-off module.
- Fastening screws.

## Installation



**Caution: Before you begin, turn off the printer and disconnect the power cord and communication cables.**

1. Turn the printer off and disconnect the power cord.
2. Press in on the cover latches on both sides of the printer and open the cover.
3. Press in both locking buttons to open the print and ribbon mechanism.

4. Remove the tear bar by pushing it upwards.

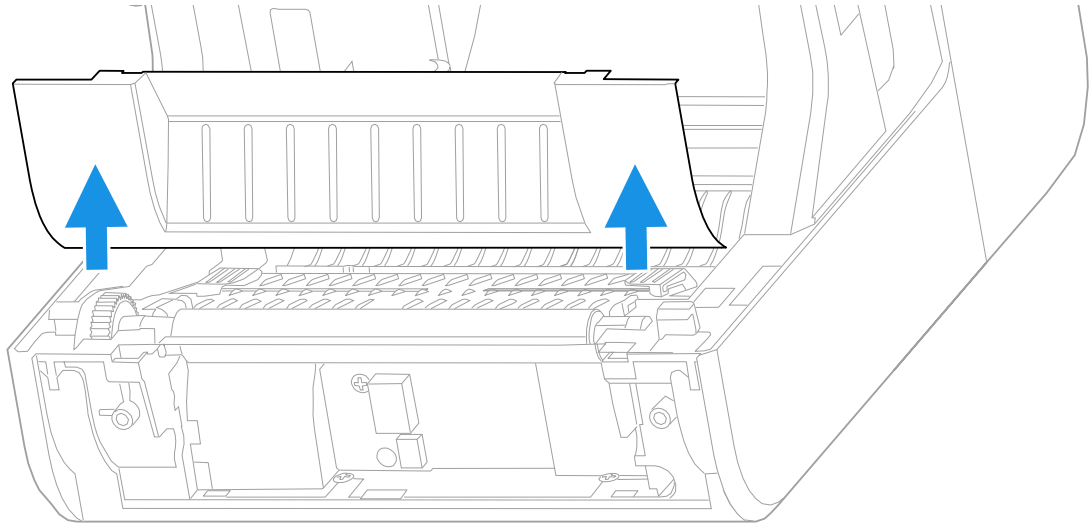

5. Insert the cable on the peel-off module into the connector on the printer.

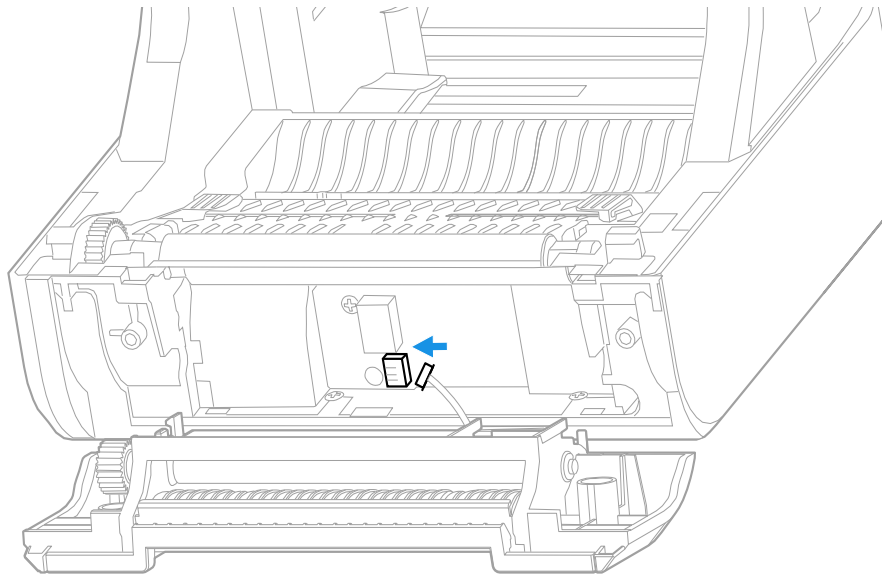

6. Lift the peel-off module into the printer until it clicks into place.

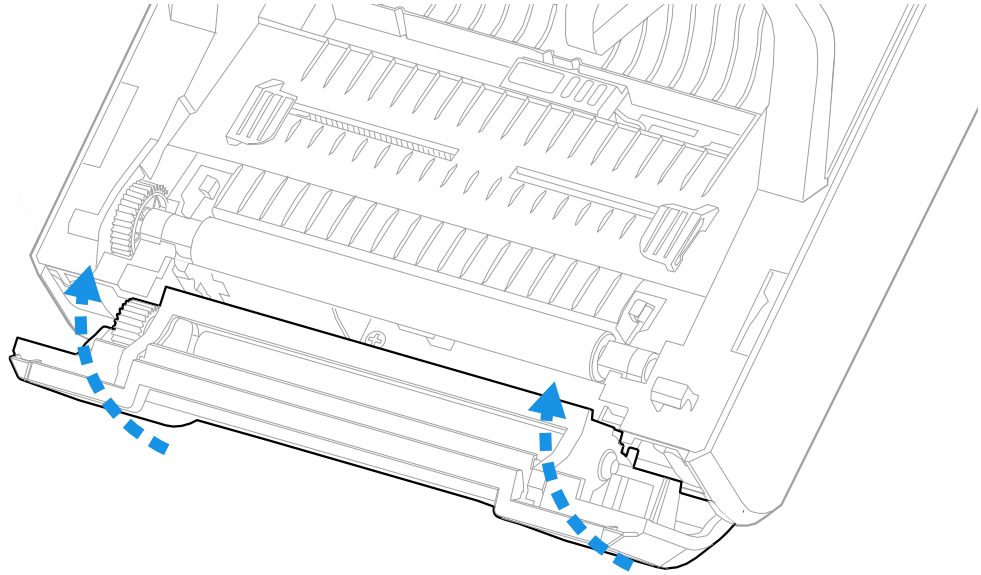

7. Press in both buttons on the front of the peel-off module to open the module door.

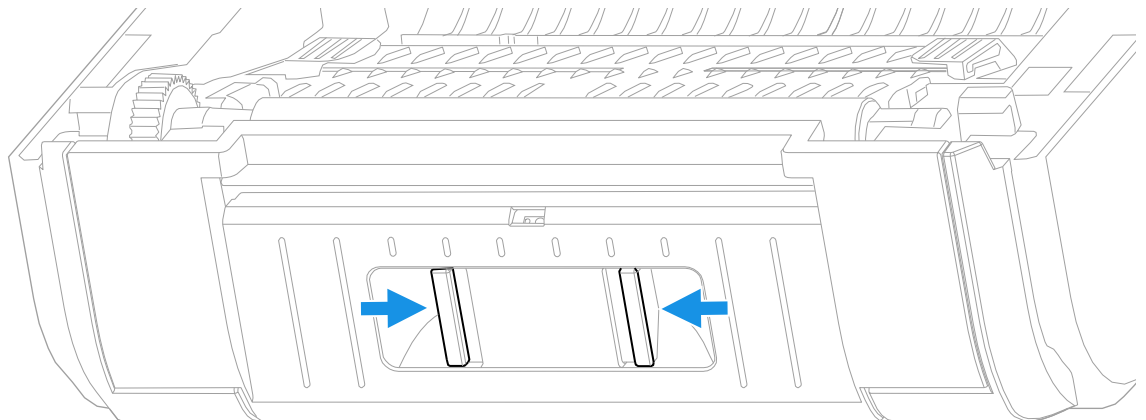

8. Use a Phillips screwdriver to insert the screws that fasten the peel-off module to the printer.

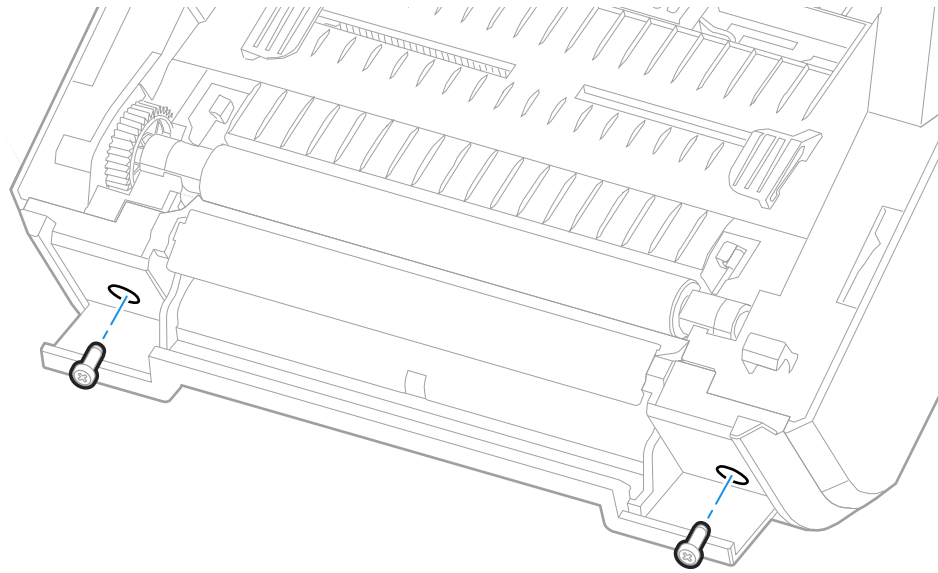

9. Load media over the bar on top of the peel-off module. Pass the media between the two rollers inside the module and out of the opening at the bottom of the module.

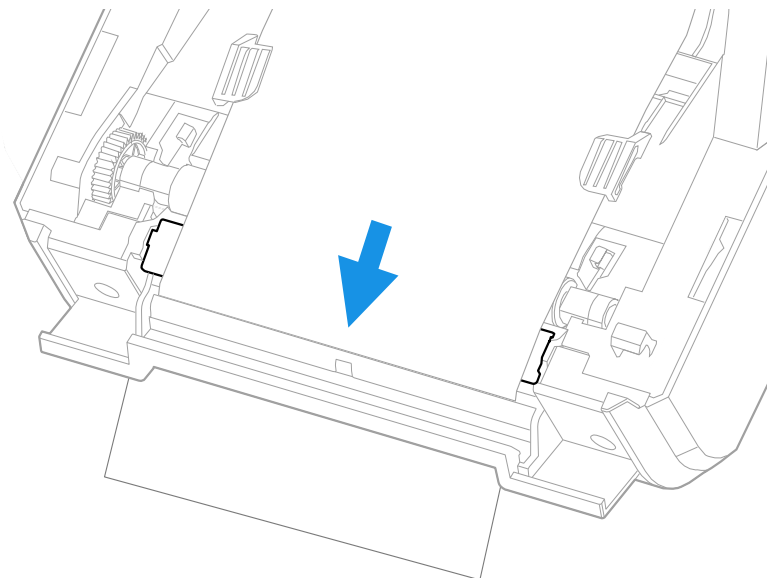

10. Close the door on the peel-off module.
11. Close the print and ribbon mechanism and the printer cover.

# Bluetooth/Wi-Fi Module

The Bluetooth/Wi-Fi module allows you to connect to the printer with a Bluetooth or Wi-Fi connection.

## Out of the Box

You will find the following item in the shipping box:

- Bluetooth/Wi-Fi module
- Fastening screws

## Installation



**Caution: Before you begin, turn off the printer and disconnect the power cord and communication cables.**

1. Turn the printer off and disconnect the power cord.
2. Press in on the cover latches on both sides of the printer and open the cover.
3. Use a Phillips screwdriver to remove the screw from the module door. Hold the printer cover at approximately a 90° angle and slide the door away from the printer.

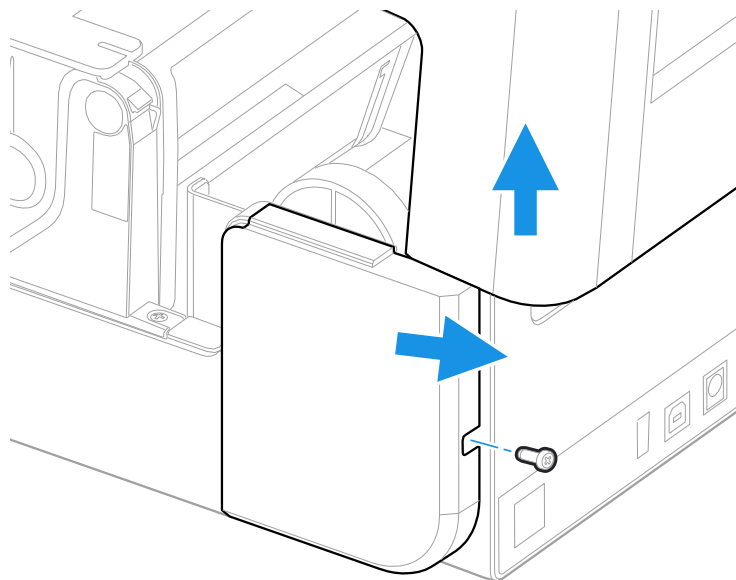

4. Insert the module into the printer and attach the module to the connectors on the printer.

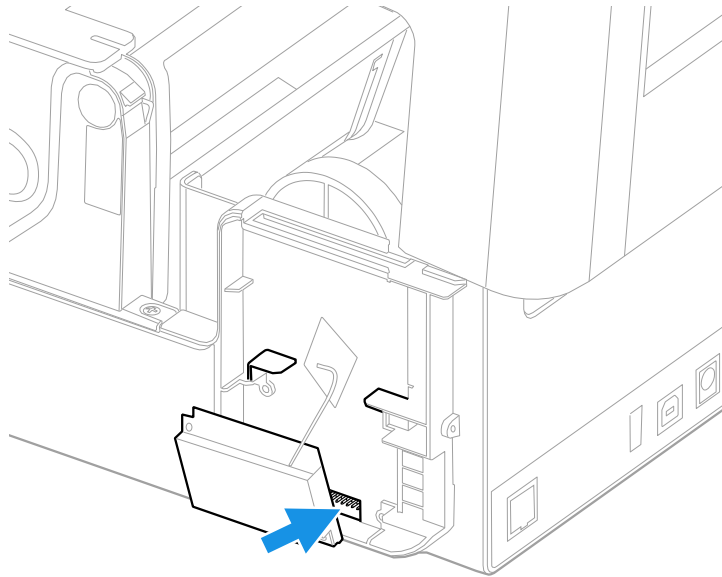

5. Use a Phillips screwdriver to insert the screws that fasten the module to the printer. Remove the adhesive backing from the antenna and attach the antenna to the printer.

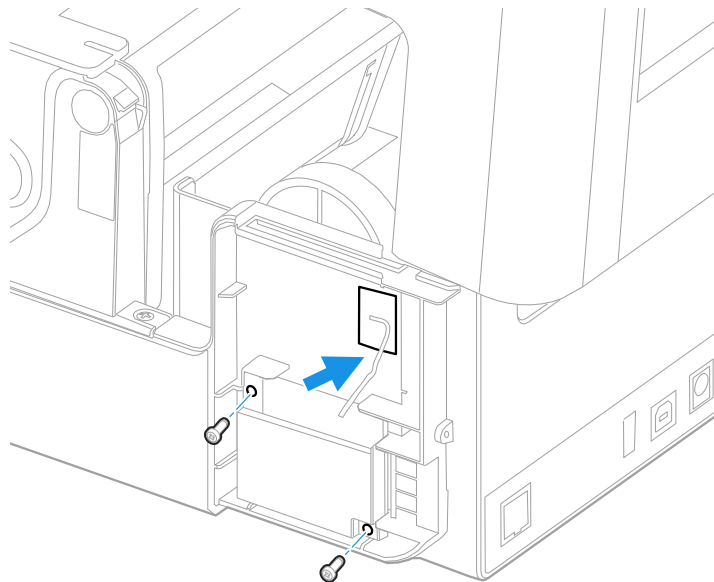

6. Replace the module door and insert the screw into the door.
7. Close the printer cover.







Honeywell  
855 S. Mint Street  
Charlotte, NC 28202

[sps.honeywell.com](http://sps.honeywell.com)