

**data**video

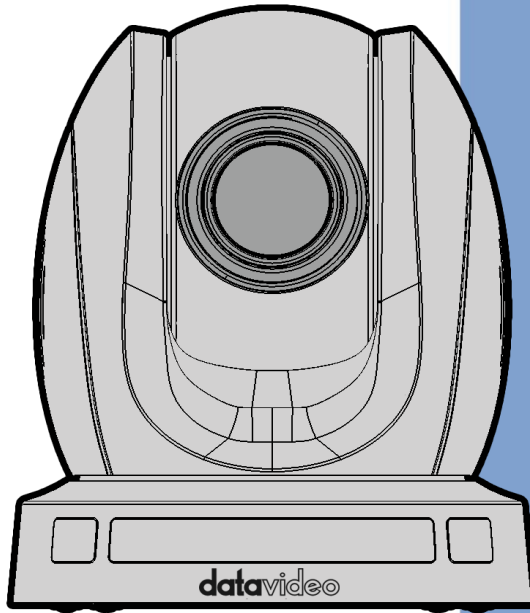

HDBASET PTZ CAMERA  
PTC-140T/PTC-140TH

**Instruction Manual**

[www.datavideo.com](http://www.datavideo.com)

# Table of Contents

TABLE OF CONTENTS .....	2
FCC COMPLIANCE STATEMENT .....	5
WARNINGS AND PRECAUTIONS .....	5
WARRANTY .....	6
<i>STANDARD WARRANTY</i> .....	6
<i>THREE YEAR WARRANTY</i> .....	7
DISPOSAL .....	7
<b>1. PRODUCT OVERVIEW .....</b>	<b>9</b>
FEATURES .....	9
EXAMPLE SETUP .....	10
<b>2. LOCATION AND FUNCTION OF PARTS .....</b>	<b>11</b>
2.1 CAMERA.....	11
<i>Front</i> .....	11
<i>Rear</i> .....	12
<i>Bottom</i> .....	13
2.2 RECEIVER BOX.....	14
<i>Front</i> .....	14
<i>Rear</i> .....	15
<b>3. BASIC SETUP .....</b>	<b>17</b>
<b>3.1 POWER-ON INITIALIZATION .....</b>	<b>17</b>
<b>3.2 VIDEO OUTPUT .....</b>	<b>17</b>
<i>Ethernet Port</i> .....	17
<i>HDBaseT Port</i> .....	18
<b>3.3 CONNECT TO HS-1600T HDBASET PORTABLE VIDEO STREAMING STUDIO ...</b>	<b>18</b>
<b>4. REMOTE CONTROL AND ON-SCREEN MENU.....</b>	<b>20</b>
4.1 REMOTE CONTROL FUNCTIONS.....	20
4.2 ON-SCREEN MENU .....	25
<b>5. HOW TO USE THE TALLY LIGHT OPTION IN THE OSD MENU .....</b>	<b>32</b>
<b>6. NETWORK CONNECTION.....</b>	<b>45</b>

6.1	DHCP MODE.....	47
6.2	STATIC IP .....	49
6.3	DVIP.....	49
<b>7.</b>	<b>WEB USER INTERFACE.....</b>	<b>53</b>
7.1	PREVIEW .....	53
	<i>Control Functions</i> .....	54
	<i>Preset</i> .....	55
7.2	CONFIGURATION.....	56
	<i>Audio Configure</i> .....	56
	<i>Video Configure</i> .....	58
	<i>Video Encode</i> .....	58
	<i>Stream Publish</i> .....	61
	<i>RTP Multicast</i> .....	88
	<i>Video Parameters</i> .....	90
	<i>Video OSD</i> .....	98
	<i>OSD Font Size</i> .....	100
	<i>Video OUT</i> .....	100
	<i>Network Configure</i> .....	101
	<i>Network Port</i> .....	102
	<i>Ethernet</i> .....	102
	<i>DNS</i> .....	103
	<i>SRT</i> .....	104
	<i>System Configure</i> .....	104
	<i>System Attribute</i> .....	104
	<i>System Time</i> .....	105
	<i>System User</i> .....	106
	<i>Update</i> .....	107
	<i>Default</i> .....	107
	<i>Reboot</i> .....	108
<b>8.</b>	<b>REMOTE CONTROL PORT PINOUT .....</b>	<b>109</b>
<b>9.</b>	<b>FIRMWARE UPDATE.....</b>	<b>111</b>
	REQUIREMENTS .....	111
	PROCEDURE .....	111
<b>10.</b>	<b>FREQUENTLY-ASKED QUESTIONS.....</b>	<b>112</b>
<b>11.</b>	<b>DIMENSIONS.....</b>	<b>114</b>

<b>12. SPECIFICATIONS.....</b>	<b>116</b>
CABLE SELECTION.....	118
<b>SERVICE &amp; SUPPORT.....</b>	<b>120</b>

**Disclaimer of Product and Services**

The information offered in this instruction manual is intended as a guide only. At all times, Datavideo Technologies will try to give correct, complete and suitable information. However, Datavideo Technologies cannot exclude that some information in this manual, from time to time, may not be correct or may be incomplete. This manual may contain typing errors, omissions or incorrect information. Datavideo Technologies always recommend that you double check the information in this document for accuracy before making any purchase decision or using the product. Datavideo Technologies is not responsible for any omissions or errors, or for any subsequent loss or damage caused by using the information contained within this manual. Further advice on the content of this manual or on the product can be obtained by contacting your local Datavideo Office or dealer.

## **FCC Compliance Statement**

This device complies with part 15 of the FCC rules. Operation is subject to the following two conditions:

- (1) This device may not cause harmful interference, and
- (2) This device must accept any interference received, including interference that may cause undesired operation.

## **Warnings and Precautions**

1. Read all of these warnings and save them for later reference.
2. Follow all warnings and instructions marked on this unit.
3. Unplug this unit from the wall outlet before cleaning. Do not use liquid or aerosol cleaners. Use a damp cloth for cleaning.
4. Do not use this unit in or near water.
5. Do not place this unit on an unstable cart, stand, or table. The unit may fall, causing serious damage.
6. Slots and openings on the cabinet top, back, and bottom are provided for ventilation. To ensure safe and reliable operation of this unit, and to protect it from overheating, do not block or cover these openings. Do not place this unit on a bed, sofa, rug, or similar surface, as the ventilation openings on the bottom of the cabinet will be blocked. This unit should never be placed near or over a heat register or radiator. This unit should not be placed in a built-in installation unless proper ventilation is provided.
7. This product should only be operated from the type of power source indicated on the marking label of the AC adapter. If you are not sure of the type of power available, consult your Datavideo dealer or your local power company.
8. Do not allow anything to rest on the power cord. Do not locate this unit where the power cord will be walked on, rolled over, or otherwise stressed.
9. If an extension cord must be used with this unit, make sure that the total of the ampere ratings on the products plugged into the extension cord do not exceed the extension cord's rating.
10. Make sure that the total amperes of all the units that are plugged into a single wall outlet do not exceed 15 amperes.

11. Never push objects of any kind into this unit through the cabinet ventilation slots, as they may touch dangerous voltage points or short out parts that could result in risk of fire or electric shock. Never spill liquid of any kind onto or into this unit.
12. Except as specifically explained elsewhere in this manual, do not attempt to service this product yourself. Opening or removing covers may expose you to dangerous voltage points or other risks, and will void your warranty. Refer all service issues to qualified service personnel.
13. Unplug this product from the wall outlet and refer to qualified service personnel under the following conditions:
  - a. When the power cord is damaged or frayed;
  - b. When liquid has spilled into the unit;
  - c. When the product has been exposed to rain or water;
  - d. When the product does not operate normally under normal operating conditions. Adjust only those controls that are covered by the operating instructions in this manual; improper adjustment of other controls may result in damage to the unit and may often require extensive work by a qualified technician to restore the unit to normal operation;
  - e. When the product has been dropped or the cabinet has been damaged;
  - f. When the product exhibits a distinct change in performance, indicating a need for service.

## **Warranty**

### ***Standard Warranty***

- Datavideo equipment are guaranteed against any manufacturing defects for one year from the date of purchase.
- The original purchase invoice or other documentary evidence should be supplied at the time of any request for repair under warranty.
- The product warranty period begins on the purchase date. If the purchase date is unknown, the product warranty period begins on the thirtieth day after shipment from a Datavideo office.
- All non-Datavideo manufactured products (product without Datavideo logo) have only one year warranty from the date of purchase.
- Damage caused by accident, misuse, unauthorized repairs, sand, grit or water is not covered under warranty.

- Viruses and malware infections on the computer systems are not covered under warranty.
- Any errors that are caused by unauthorized third-party software installations, which are not required by our computer systems, are not covered under warranty.
- All mail or transportation costs including insurance are at the expense of the owner.
- All other claims of any nature are not covered.
- All accessories including headphones, cables, and batteries are not covered under warranty.
- Warranty only valid in the country or region of purchase.
- Your statutory rights are not affected.

### ***Three Year Warranty***

- All Datavideo products purchased after July 1st, 2017 are qualified for a free two years extension to the standard warranty, providing the product is registered with Datavideo within 30 days of purchase.
- Certain parts with limited lifetime expectancy such as LCD panels, DVD drives, Hard Drive, Solid State Drive, SD Card, USB Thumb Drive, Lighting, Camera module, PCIe Card are covered for 1 year.
- The three-year warranty must be registered on Datavideo's official website or with your local Datavideo office or one of its authorized distributors within 30 days of purchase.



## **Disposal**

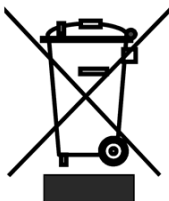

### **For EU Customers only - WEEE Marking**

This symbol on the product or on its packaging indicates that this product must not be disposed of with your other household waste. Instead, it is your responsibility to dispose of your waste equipment by handing it over to a designated collection point for the recycling of waste electrical and electronic equipment. The separate collection and recycling of your waste equipment at the time of disposal will help to conserve natural resources and ensure that it is recycled in a manner that protects human health and the environment. For more information about where you can drop

off your waste equipment for recycling, please contact your local city office, your household waste disposal service or the shop where you purchased the product.



**CE Marking** is the symbol as shown on the left of this page. The letters "CE" are the abbreviation of French phrase "Conformité Européene" which literally means "European Conformity". The term initially used was "EC Mark" and it was officially replaced by "CE Marking" in the Directive 93/68/EEC in 1993. "CE Marking" is now used in all EU official documents.



# 1. Product Overview

The PTC-140T is a low-cost HDBT PTZ camera featuring PoE functionality, 20x optical zoom and 10x digital zoom. The camera is capable of transmitting uncompressed videos (1080p60/50) up to 100 meters.

The PTC-140T is also supporting H.264 /H.265 video compression and dual stream outputs.

## Features

- 1/2.8 inch CMOS sensor. Resolution is up to 1920x1080 with frame rate up to 60fps.
- Low Noise CMOS effectively ensures high SNR of camera video. Advanced 2D/3D noise reduction technology is also used to further reduce the noise, while ensuring image sharpness.
- Audio Input Interface
- Supports AAC, MP3 and G.711A audio coding with sampling frequencies of 16000, 32000, 44100 and 48000.
- Supports H.264/H.265 video compressions of resolution up to 1920x1080 with frame rate up to 60fps (single channel) or 1920x1080 with frame rate up to 30fps (dual channel) as well as AAC, MP3 and G.711A audio compressions.
- Supports multiple network protocols such as RTSP and RTMP allowing you to easily link to any streaming media servers.

# Example Setup

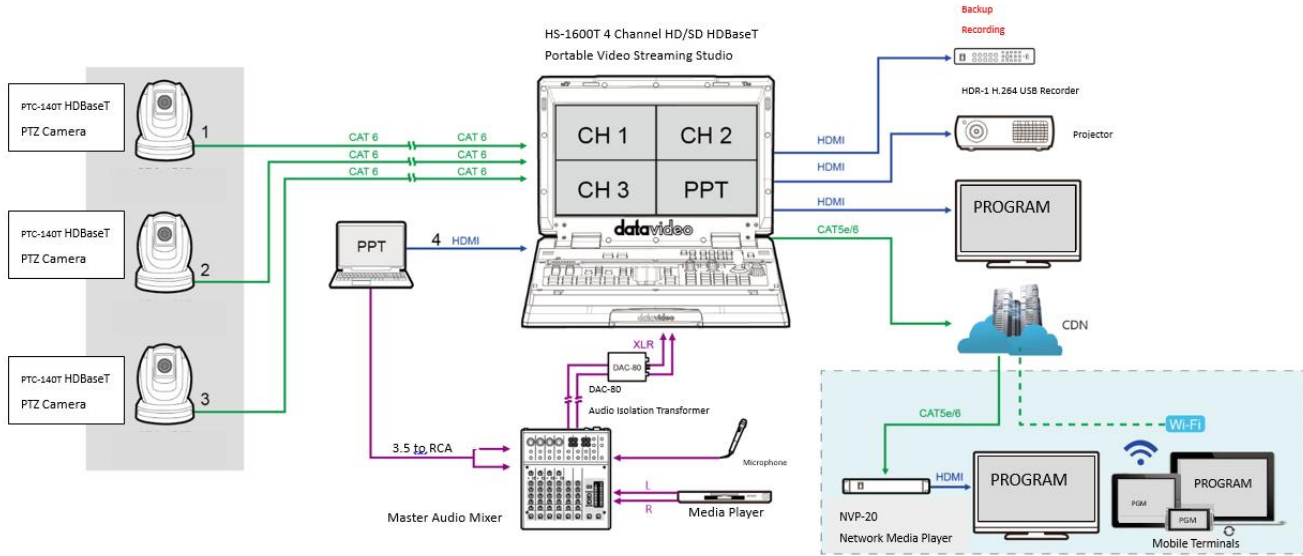

## 2. Location and Function of Parts

### 2.1 Camera

#### Front

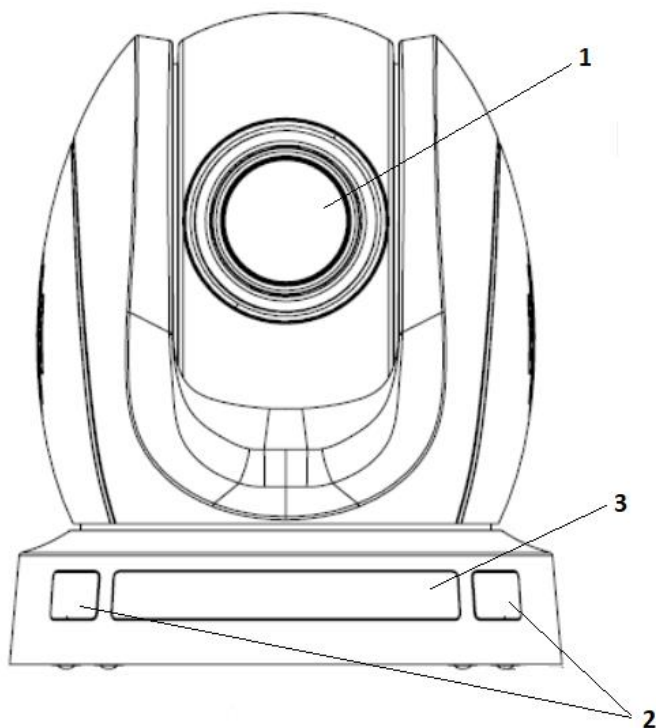

1	<b>Lens</b> Built-in 1/2.8" 2.07M Pixel CMOS HD color camera with white balance control, backlight compensation settings, automatic gain settings and etc.
2	<b>Tally LED</b> Tally lamp lights up when tally signal has been transmitted to the tally signal box.
3	<b>Sensor for Remote Control</b> Remote controller receiver

## Rear

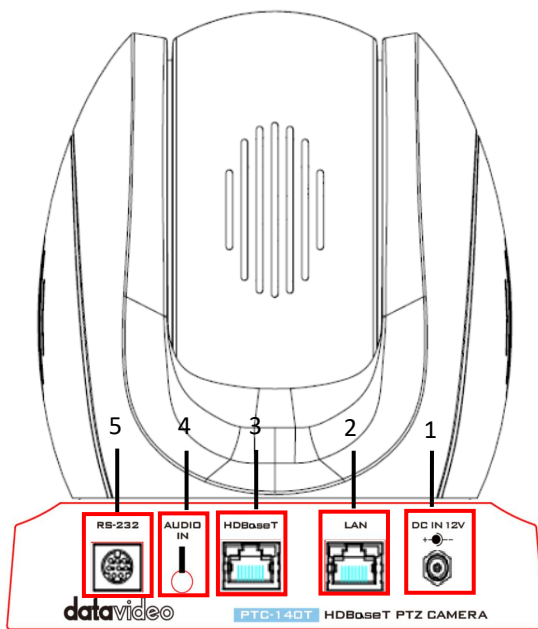

1	<p><b>Power Input</b></p> <p>DC in socket connects the supplied 12V PSU. The connection can be secured by screwing the outer fastening ring of the DC In plug to the socket.</p>
2	<p><b>LAN Port</b></p> <p>This bidirectional port allows you to establish network connection with the camera. Connect an Ethernet cable from this port to the LAN port of a PC in order to monitor the camera video from the web user interface. The LAN port also allows you to stream the camera video using various streaming protocols.</p>
3	<p><b>HDBaseT Communication Port</b></p> <p>Connects the camera to the receiver box, thereby extending video transmission up to 100m. Use a CAT5e/6 Ethernet cable to connect this port to the HDBaseT port of the receiver box which in turn outputs the HDMI video to an externally connected monitor.</p>
4	<p><b>Audio Input Interface</b></p> <p>The 3.5mm audio input receives external audio.</p>
5	<p><b>8 pin mini-Din RS-232 Port</b></p> <p>Use an 8 pin mini-Din to DB9 adapter cable to connect the camera to an RS-232 remote controller.</p>

## Bottom

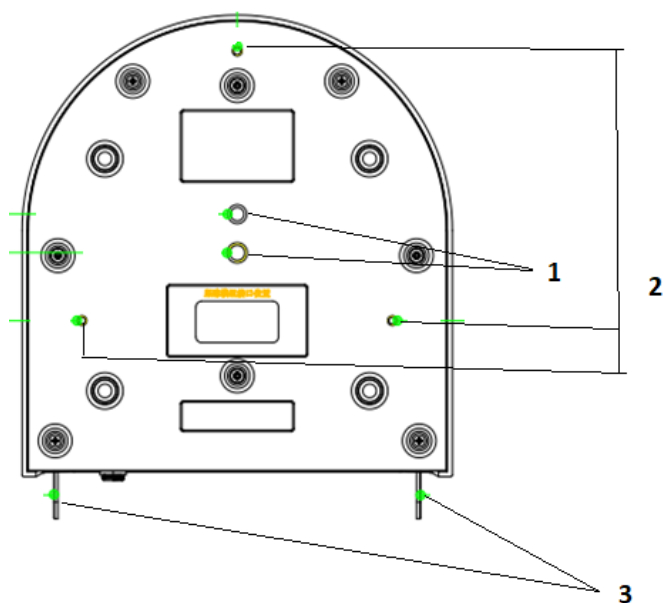



1	<b>Tripod Screw Hole</b> allows the user to mount the camera on the tripod.
2	<b>Screw Hole</b> Screw holes for ceiling bracket mounting.
3	<b>For Safety Rope</b> Ties safety rope for securing the camera to the ceiling.

## 2.2 Receiver Box

**Note:** The receiver box is not an accessory of the PTC-140T and comes with the PTC-140TH only.

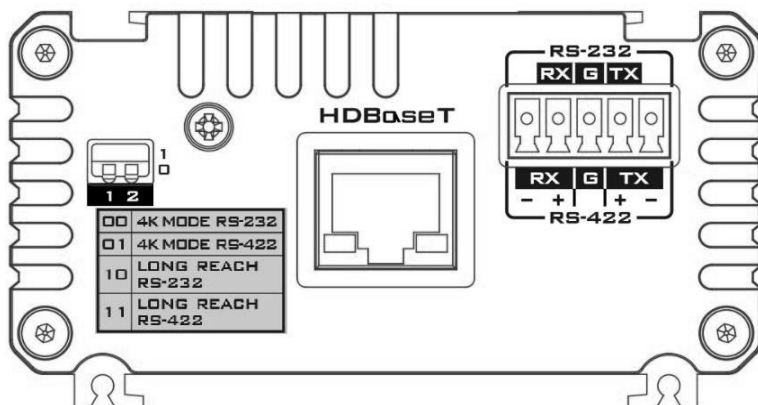
### Front



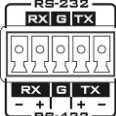

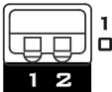
	<p><b>HDBaseT</b></p> <p>Port for connecting the PTC-140T camera's HDBaseT Port using a CAT5e/6 Ethernet cable.</p>
	<p><b>RS-232/RS-422 Interface (Phoenix Terminal)</b></p> <p>Connects to an external RS-232/RS-422 device.</p> <p><b>RX:</b> Receiver PIN (differential pair if using the RS-422 interface to connect)</p> <p><b>TX:</b> Transmitter PIN (differential pair if using the RS-422 interface to connect)</p> <p><b>G:</b> Ground PIN</p>

	<p><b>DIP Switch</b></p> <p>The receiver box extends the video transmission distance up to 100 meters. Select 4K mode (2160p) if the video transmission distance is less than 70 meters. Select long reach mode if the video transmission distance is more than 70 meters but less than 100 meters at the expense of video quality (1080p). Use the DIP Switch to select the mode of connection. The available options are listed as follows.</p> <p><b>00:</b> 4K Mode RS-232  <b>01:</b> 4K Mode RS-422  <b>10:</b> Long Reach RS-232  <b>11:</b> Long Reach RS-422</p>
---	---

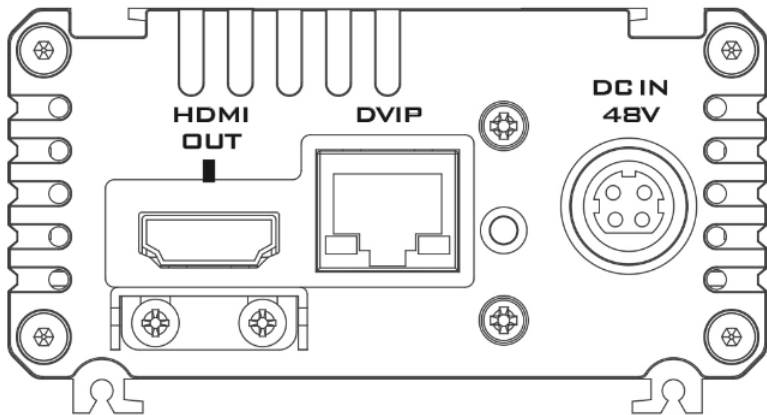
**Rear**



<p>DC IN 48V</p> 	<p><b>DC In Socket</b></p> <p>Connects the supplied 48V PSU to this socket. The connection can be secured by screwing the outer fastening ring of the DC In plug to the socket.</p>
<p>HDMI OUT</p> 	<p><b>HDMI OUT</b></p> <p>The HDMI OUT can be connected to a monitor display.</p>

DVIP



### **DVIP Communication Port**

Connect the **DVIP** port to an **Ethernet switch or router**, serving as a communication port between the network and the receiver box.



### 3. Basic Setup

#### 3.1 Power-On Initialization

As shown in the diagram below, after you plug in the power cord, the tally light in the front will start flashing red and will stop flashing as soon as the power-on initialization is complete. The camera head should be at the HOME position with the lens facing front. However, if preset 0 is set, it will return to the 0<sup>th</sup> preset position.

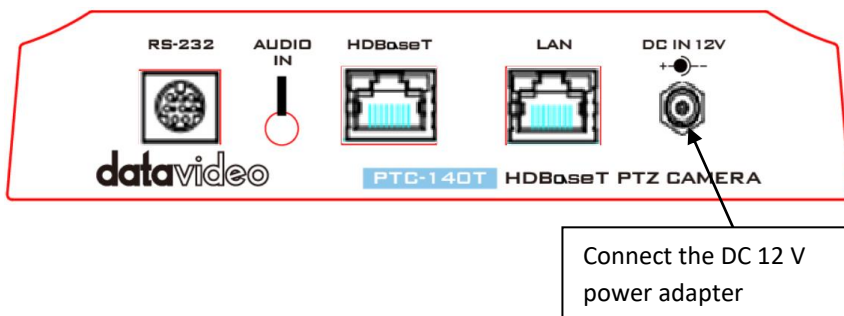

#### 3.2 Video Output

You are allowed to view the camera video via **Ethernet and HDBaseT ports**.

##### Ethernet Port

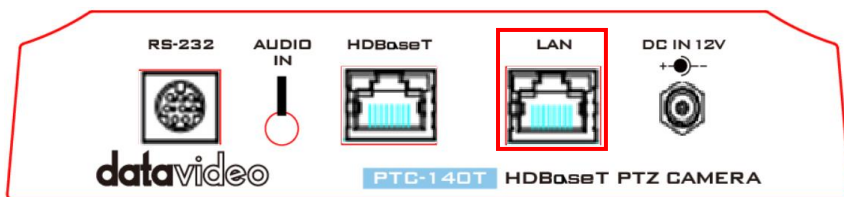

Follow the instructions below to view your video on the web user interface.

1. Connect the PTC-140T to the PC/Notebook using an Ethernet cable.
2. On your PC/Notebook, open the web browser and enter the camera's default IP address into the address bar (default static IP address is 192.168.5.163).
3. On the Login page enter the username and password which are admin/admin respectively by default.

4. Click into the preview window on which the video will be displayed.

## HDBaseT Port

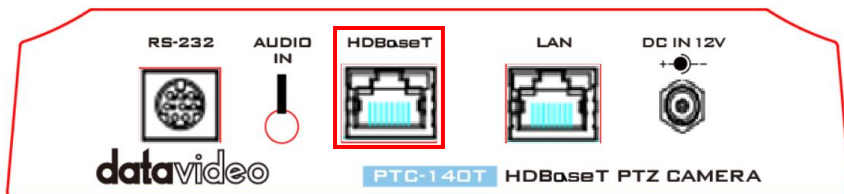

Follow the instructions below to view your video on an externally connected monitor via the HDBaseT port.

1. Use an Ethernet cable to connect the PTC-140T's HDBaseT port to the HDBaseT port of the receiver box.
2. Connect the HDMI OUT port of the receiver box to the HDMI port of an external monitor.
3. Connect the camera power to view the camera video on the connected monitor.

### 3.3 Connect to HS-1600T HDBaseT Portable Video Streaming Studio

The PTC-140T can be connected to the HS-1600T 4 Channel HD/SD HDBaseT Portable Video Streaming Studio via HDBaseT. Simply connect the HDBaseT ports on two ends with an Ethernet cable (See [Example Setup](#)).

Please note that the baud rate of the HDBaseT port on the HS-1600T has been fixed at 38400 and cannot be changed by the user. The default baud rate of the PTC-140T camera is also 38400 so if your camera is new and it's your first time using the device, you can simply connect the PTC-140T to the HS-1600T without making any change to the baud rate.

However if your PTC-140T has been used somewhere else with a different baud rate, you can access the camera's OSD menu to change it back to 38400. Simply follow the menu path "Setup → Baud Rate" then select 38400. Also make sure the protocol under the Setup sub menu has been set to Auto.

After the PTC-140T has successfully established connection with the HS-1600T, you have to make sure the camera video has the same video format as the switcher's PGM OUT resolution.



On the HS-1600T, press the MENU button on the keyboard to open the OSD menu where you should find the switcher's PGM OUT resolution. Then follow the menu path, Camera → PTC-140T → Video → Video Format, to set the camera video format to the PGM OUT resolution. Remember to save the new setting by selecting "Save" in Save Setup of the Setup sub menu.



## 4. Remote Control and On-Screen Menu





This chapter provides an overview of remote control functions and the OSD menu.



### 4.1 Remote Control Functions



No	Function Keys	Descriptions
1	<p data-bbox="262 228 400 252"><b>Standby Key</b></p> 	<p data-bbox="471 165 610 193"><b>Standby Key</b></p> <p data-bbox="471 197 981 225">The standby button turns <b>ON/OFF</b> the camera.</p> <p data-bbox="471 261 994 387">To reboot the camera, press the standby button for 3 seconds. After device initialization is complete, the camera head will automatically return to <b>HOME</b> position.</p>
2	<p data-bbox="225 549 441 572"><b>Camera Select Keys</b></p> 	<p data-bbox="471 437 687 464"><b>Camera Select Keys</b></p> <p data-bbox="471 469 1020 659">To select a camera in a multi-camera environment using camera select keys (CAM1 – CAM4), you should first assign an ID number to the camera intended for operation using F1 – F4 keys then press CAMERA SELECT (CAM 1~ CAM4) keys to navigate between the four cameras.</p> <p data-bbox="471 695 1014 754"><b>Note: See F1 – F4 keys for ID number assignment instructions.</b></p>
3	<p data-bbox="241 999 423 1026"><b>Number Keypad</b></p> 	<p data-bbox="471 794 654 821"><b>Number Keypad</b></p> <p data-bbox="471 826 969 885">Set, recall and clear presets using the number keypad.</p> <p data-bbox="471 922 586 949"><b>Set Preset</b></p> <p data-bbox="471 954 1001 1112">Please press the <b>SET PRESET</b> at first, and then please press any of the <b>number keys from 0 to 9</b> to save the PTZ settings. You will be allowed to save up to <b>up to 10 presets using the remote control.</b></p> <p data-bbox="471 1155 591 1182"><b>Call Preset</b></p> <p data-bbox="471 1187 1020 1246">Press any of the <b>number keys from 0 to 9</b> to recall the preset settings.</p> <p data-bbox="471 1251 994 1342"><b>Note: Make sure the preset that you want to recall contains PTZ settings before pressing the number key.</b></p> <p data-bbox="471 1378 609 1406"><b>Clear Preset</b></p> <p data-bbox="471 1410 936 1469">First press the <b>CLEAR/PRESET</b> key then the <b>number key (0 – 9)</b> to empty the preset.</p>

No	Function Keys	Descriptions
4	<p data-bbox="225 647 440 703"><b>Asterisk and Pound Keys</b></p> 	<p data-bbox="471 180 981 268">The asterisk and pound keys form various combinations with other keys to access certain functions directly.</p> <p data-bbox="471 277 846 301">The shortcuts are listed as follows:</p> <ol data-bbox="482 311 1020 1251" style="list-style-type: none"> <li data-bbox="482 311 930 335">1. <b>【#】 + 【#】 + 【#】</b> : Clear all presets</li> <li data-bbox="482 344 1020 368">2. <b>【*】 + 【#】 + 【6】</b> : Restore factory defaults</li> <li data-bbox="482 378 930 437">3. <b>【*】 + 【#】 + 【9】</b> : Image flip along horizontal axis</li> <li data-bbox="482 446 967 470">4. <b>【*】 + 【#】 + AUTO</b>: Enable aging mode</li> <li data-bbox="482 480 973 504">5. <b>【#】 + 【*】 + AUTO</b>: Disable aging mode</li> <li data-bbox="482 513 922 572">6. <b>【*】 + 【#】 + 【3】</b> : Set OSD MENU language to Chinese.</li> <li data-bbox="482 582 922 641">7. <b>【*】 + 【#】 + 【4】</b> : Set OSD MENU language to English.</li> <li data-bbox="482 651 1020 710">8. <b>【*】 + 【#】 + MANUAL</b>: Restore default user name, password, and IP address.</li> <li data-bbox="482 719 967 778">9. <b>【#】 + 【#】 + 【0】</b> : Set video format to 1080P60.</li> <li data-bbox="482 788 967 847">10. <b>【#】 + 【#】 + 【1】</b> : Set video format to 1080P50</li> <li data-bbox="482 857 967 916">11. <b>【#】 + 【#】 + 【2】</b> : Set video format to 1080I60</li> <li data-bbox="482 925 967 984">12. <b>【#】 + 【#】 + 【3】</b> : Set video format to 1080I50</li> <li data-bbox="482 994 967 1053">13. <b>【#】 + 【#】 + 【4】</b> : Set video format to 720P60</li> <li data-bbox="482 1062 967 1121">14. <b>【#】 + 【#】 + 【5】</b> : Set video format to 720P50</li> <li data-bbox="482 1131 967 1190">15. <b>【#】 + 【#】 + 【6】</b> : Set video format to 1080P30</li> <li data-bbox="482 1200 967 1259">16. <b>【#】 + 【#】 + 【7】</b> : Set video format to 1080P25</li> </ol>
5	<p data-bbox="264 1326 400 1350"><b>AUTO Focus</b></p> 	<p data-bbox="471 1350 605 1374"><b>AUTO Focus</b></p> <p data-bbox="471 1383 969 1407">Pressing this key will enable auto focus mode.</p>

No	Function Keys	Descriptions
6	<p><b>Manual Mode</b></p> 	<p><b>Manual Focus</b> Pressing this key enables manual mode allowing you to adjust the camera's focus and zoom by pressing <b>Focus+/-</b> and <b>Zoom+/-</b> keys.</p>
7	<p><b>Focus +/-</b></p> 	<p><b>Focus</b> Press and hold <b>Focus+ or Focus-</b> to adjust the focus accordingly and release as soon as the desired focus is reached.</p> <p><b>Note: Before adjusting the focus using Focus +/- key, press the manual key to enable manual mode.</b></p>
8	<p><b>Zoom In (+) / Zoom Out (-)</b></p> 	<p><b>Zoom</b> Press and hold <b>Zoom + or Zoom-</b> to zoom in and out respectively and release as soon as the desired zoom is reached.</p> <p><b>Note: Before adjusting the zoom using Zoom +/- key, press the manual key to enable manual mode.</b></p>
9	<p><b>SET PRESET</b></p> 	<p><b>SET PRESET</b> Press <b>SET PRESET</b> to set presets. See <b>Number Keypad</b> description for instructions.</p>
10	<p><b>CLEAR PRESET</b></p> 	<p><b>CLEAR PRESET</b> Press <b>CLEAR PRESET</b> to clear presets. See <b>Number Keypad</b> description for instructions.</p>

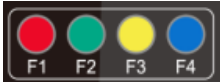
No	Function Keys	Descriptions
11-13	<p><b>Direction Arrows</b></p> 	<p><b>Direction Arrow Keys</b> Press the arrow keys to move the camera head up, down, left and right.</p> <p><b>Home Key</b> Press <b>Home</b> to <b>return the camera head to the center</b>.</p> <p><b>Note: In the OSD menu, press Home to enter the selected option item and MENU to exit.</b></p>
14	<p><b>MENU</b></p> 	<p><b>MENU</b> Open or close the camera's OSD menu.</p>
15	<p><b>BLC ON/OFF</b></p> 	<p><b>BLC ON/OFF</b> Press <b>BLC ON/OFF</b> to turn ON/OFF the backlight compensation.</p>
16	<p><b>F1 – F4 Keys</b></p> 	<p><b>F1 – F4 Keys</b> Assign an ID number to the camera intended for operation using F1 – F4 keys by pressing the combination keys as described below.</p> <ul style="list-style-type: none"> <li>• CAM1: [ * ] + [ # ] + [ F1 ]</li> <li>• CAM2: [ * ] + [ # ] + [ F2 ]</li> <li>• CAM3: [ * ] + [ # ] + [ F3 ]</li> <li>• CAM4: [ * ] + [ # ] + [ F4 ]</li> </ul> <p>Use Camera Select keys to select the camera intended for operation after you've assigned an ID number to each camera.</p>

**Note:** Pressing [ \* ] + [ # ] + MANUAL buttons restores the device's default IP address (192.168.5.163)



## 4.2 On-Screen Menu

The On-Screen Menu allows the user to modify various camera settings. Press **[MENU]** on the **remote control** to open the on-screen menu as shown below.

On-Screen MENU
1: Language
2: Setup
3: Camera
4: P/T/Z
5: Video Format
6. Network Settings
7: Version
8: Restore Default
9: Escape
<b>[↑↓]Select</b> <b>[← →]Change Value</b>
<b>[Menu] Back</b> <b>[Home] OK</b>

The table below summarizes the main options and their sub-options.

Main Options								
	Language	Setup	Camera	P/T/Z	Video Format	Network Settings	Version	Restore Default
Sub-Options	English	Protocol	Exposure	Zoom by Speed	1080P60	DHCP	MCU Version	Restore Default
	Simplified Chinese	VISCA Address	Color	Zoom Speed	1080P50	IP Addr	Camera Version	
		VISCA Address Fix	Image	Image Freezing	1080I60		AF Version	
		PELCO-P Address	Focus	Acc Curve	1080I50			
		PELCO-D Address	Noise Reduction		1080P30			
		Baudrate	Style		1080P25			
		Tally Light			720P60			
					720P50			
					1080P59.94			
					1080I59.94			
					1080P29.97			
					720P59.94			

Details of all options in the OSD menu are listed in the table below.

First Level Main Options	Second Level Sub-Options	Third Level Parameters	Fourth Level Parameters
<b>1. Language (English/Simplified Chinese)</b>			
<b>2. Setup</b>	Protocol	1. Auto	
		2. VISCA	
		3. PELCCO-D	
		4. PELCCO-P	
	VISCCA Address	1-7	
	VISCA Address Fix	ON/OFF	
	PELCO-P Address	1-255	
	PELCO-D Address	1-255	
	Baudrate	2400	
		4800	
		9600	
		38400	
		115200	
	Tally Light	RED	
		GREEN	
RED/GREEN			
OFF			
<b>3. Camera</b>	Exposure	Mode	Auto
			Manual
			SAE
		EV	AAE
			Bright
		EV Level	ON
	OFF		
	0		
	1		
	2		
	3		
	4		
	5		
6			
7			
-7			
-6			
-5			

			-4
			-3
			-2
			-1
		BLC	ON
			OFF
		Flicker	OFF
			50Hz
			60Hz
		Gain Limit	0~15
			Closed
			1
			2
			3
			4
			5
			6
			7
			8
			Auto
			3000K
			3500K
			4000K
			4500K
			5000K
			5500K
			6000K
			6500K
			7000K
			Manual
			Onepush
			0
			1
			2
			3
			4
			5
			6
			7
			8
			9
			10
			-10
			-9
			-8
			-7
			-6
			-5
			-4
			-3
	Color	WB Mode	
		RG Tuning	

	-2
	-1
BG Tuning	0
	1
	2
	3
	4
	5
	6
	7
	8
	9
	10
	-10
	-9
	-8
	-7
	-6
	-5
	-4
-3	
-2	
-1	
Saturation	60%
	70%
	80%
	90%
	100%
	110%
	120%
	130%
	140%
	150%
	160%
	170%
180%	
190%	
200%	
Hue	0
	1
	2
	3
	4
	5
	6
	7
	8
	9
	10
	11

Image	AWB Sensitivity	12
		13
		14
	Brightness	High
		Low
		Middle
	Contrast	0
		1
		2
		3
		4
		5
		6
		7
		8
9		
10		
11		
Sharpness	12	
	13	
	14	
	0	
	1	
	2	
	3	
	4	
	5	
	6	
	7	
	8	
9		
10		
11		
12		
13		

		14
		15
	Flip-H (The camera image flips horizontally)	ON
		OFF
	Flip-V (The camera image flips vertically)	ON
		OFF
	B & W Mode	Color
		Black & White
	Gamma	Default
		0.45
		0.50
		0.55
	DZoom	ON
		OFF
	DCI	Closed
		1
		2
		3
		4
		5
		6
		7
	8	
Focus	Focus Mode	Auto
		Manual
		One Push
	AF-Zone	Top
		Center
		Bottom
All		
AF-Sensitivity	High	
	Low	
	Middle	
Noise Reduction	NR-2D	Auto
		OFF
		1
		2
		3
		4
		5
		6
	7	
	NR-3D	OFF
		1
		2
		3
		4
5		

			6
			7
			8
		Dynamic Hot Pixel	OFF
			1
			2
			3
			4
			5
	Style	Default	
		Normal	
		Clarity	
		Bright	
		Soft	
4. P/T/Z	Zoom by Speed	ON	When enabled, the camera zoom speeds up and slows down gradually
		OFF	
	Zoom Speed	1	
		2	
		3	
		4	
		5	
6			
7			
		8	
	Image Freezing	ON	
		OFF	
	Acc Curve	Slow	
		Fast	
5. Video Format	1080P60		
	1080P50		
	1080I60		
	1080I50		
	1080P30		
	1080P25		
	720P60		
	720P50		
	1080P59.94		
	1080I59.94		
	1080P29.97		
	720P59.94		
6. Network Settings	DHCP	ON	
		OFF	
	IP Addr	192.168.X.X	
7. Version	MCU Version		
	Camera Version		
	AF version		
8. Restore Default	Restore Default (Yes/No)		

## 5. How to Use the Tally Light Option in the OSD Menu

The “Tally Light” option in the PTC-140 OSD menu allows you to determine whether the “red” or “green” tally light should be lit when the PTC-140 is connecting to a video switcher (take SHOWCASE 100 as an example). The tally light of the camera will be lit in red or green according to different settings of the switcher’s “PVW (When the PVW is pressed, it will light up in green)” and “PGM (When the PGM is pressed, it will light up in red)” buttons.

At first, please press the “MENU” button which is located on PTC-140’s remote controller to open the OSD menu. After that, please go to “Setup→Tally Light” to select your desired Tally Light setting. There are four kinds of Tally Light options including “RED”, “GREEN”, “RED/GREEN” and “OFF” for your selection.

### ● When OSD Menu’s “Tally Light” option is set in “RED”

- No input source is selected by the switcher’s “PVW” and “PGM” (take channel 1 as an example), which means that the “PVW” and “PGM” channels are “OFF”. At this time, the camera’s tally light will not be lit. The diagram below is a schematic diagram.

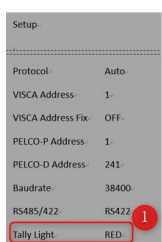

Please select “RED” for the Tally Light option.



Please set the “PGM” and “PVW” to “OFF”.



The Tally light of the camera will not be lit.



- Switcher's "PVW" is set to "ON" and the "PGM" is set to "OFF" (take channel 1 as an example). At this time, the tally light of the camera will not be lit. The diagram below is a schematic diagram.



- Switcher's "PGM" is set to "ON" and the "PVW" is set to "OFF" (take channel 1 as an example). At this time, the tally light of the camera will be lit in red. The diagram below is a schematic diagram.



- Switcher's "PGM" is set to "ON" and the "PVW" is set to "ON" (take channel 1 as an example). At this time, the tally light of the camera will be lit in red. The diagram below is a schematic diagram.



- **When OSD Menu's "Tally Light" option is set in "GREEN"**

- No input source is selected by the switcher's "PVW" and "PGM" (take channel 1 as an example), which means that the "PVW" and "PGM" channels are "OFF". At this time, the camera's tally light will not be lit. The diagram below is a schematic diagram.



- Switcher's "PGM" is set to "OFF" and the "PVW" is set to "ON" (take channel 1 as an example). At this time, the tally light of the camera will be lit in green. The diagram below is a schematic diagram.



- Switcher's "PGM" is set to "ON" and the "PVW" is set to "OFF" (take channel 1 as an example). At this time, the tally light of the camera will not be lit. The diagram below is a schematic diagram.



- Switcher's "PGM" is set to "ON" and the "PVW" is set to "ON" (take channel 1 as an example). At this time, the tally light of the camera will be lit in green. The diagram below is a schematic diagram.



- **When OSD Menu's "Tally Light" option is set in "RED"/ "GREEN"**

- No input source is selected by the switcher's "PVW" and "PGM" (take channel 1 as an example), which means that the "PVW" and "PGM" channels are "OFF". At this time, the camera's tally light will not be lit. The diagram below is a schematic diagram.



- Switcher's "PGM" is set to "OFF" and the "PVW" is set to "ON" (take channel 1 as an example). At this time, the tally light of the camera will be lit in green. The diagram below is a schematic diagram.



- Switcher's "PGM" is set to "ON" and the "PVW" is set to "OFF" (take channel 1 as an example). At this time, the tally light of the camera will be lit in red. The diagram below is a schematic diagram.



- Switcher's "PGM" is set to "ON" and the "PVW" is set to "ON" (take channel 1 as an example). At this time, the tally light of the camera will be lit in red. The diagram below is a schematic diagram.



- **When OSD Menu's "Tally Light" option is set in "OFF"**

- No input source is selected by the switcher's "PVW" and "PGM" (take channel 1 as an example), which means that the "PVW" and "PGM" channels are "OFF". At this time, the camera's tally light will not be lit. The diagram below is a schematic diagram.



- Switcher's "PGM" is set to "OFF" and the "PVW" is set to "ON" (take channel 1 as an example). At this time, the tally light of the camera will not be lit. The diagram below is a schematic diagram.



- Switcher's "PGM" is set to "ON" and the "PVW" is set to "OFF" (take channel 1 as an example). At this time, the tally light of the camera will not be lit. The diagram below is a schematic diagram.



- Switcher's "PGM" is set to "ON" and the "PVW" is set to "ON" (take channel 1 as an example). At this time, the tally light of the camera will not be lit. The diagram below is a schematic diagram.

SETUP	
Protocol	Auto
Visca Address	1
Visca Address Fix	OFF
PELCO-P Address	1
PELCO-D Address	241
Baudrate	38400
RS-485/RS-422	RS422
Tally Light	OFF

Please select "OFF" for the Tally Light option



Please select the "PGM" to "ON" and "PVW" to "ON"



The Tally light of the camera will not be lit



## 6. Installation Instructions

**Note: Only mount the bracket on formwork or concrete surface. Do NOT mount the bracket on plasterboard.**

In your product package, you should find

- PM3\*5 screw x 6
- Ceiling bracket (upper and lower plates) x 1
- PTC-140T camera x 1



Ceiling Bracket (Upper and Lower Plates)



PM3\*5 Screw x 6

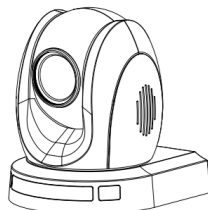

PTC-140T Camera

Additionally, you will also need the following to secure the ceiling bracket to the ceiling:

- PA4\*30 self-tapping screw x 4
- PA4 plastic screw stopper x 4



PA4\*30 Self-tapping Screw x 4



PA4 Plastic Screw Stopper x 4

### Step 1: The Ceiling Bracket

Separate the ceiling bracket into two parts (upper and lower plates) as depicted in the diagram below.

STEP 1



Ceiling Bracket

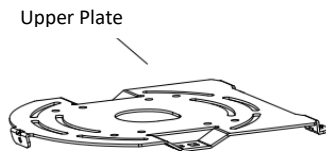

Upper Plate

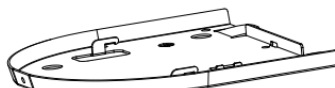

Lower Plate

### Step 2: Mount the bracket's upper plate to the ceiling

Insert the four PA4 plastic screw stoppers into the ceiling as shown in the diagram below.

Using four PA4\*30 self-tapping screws, affix the bracket's upper plate to the ceiling.

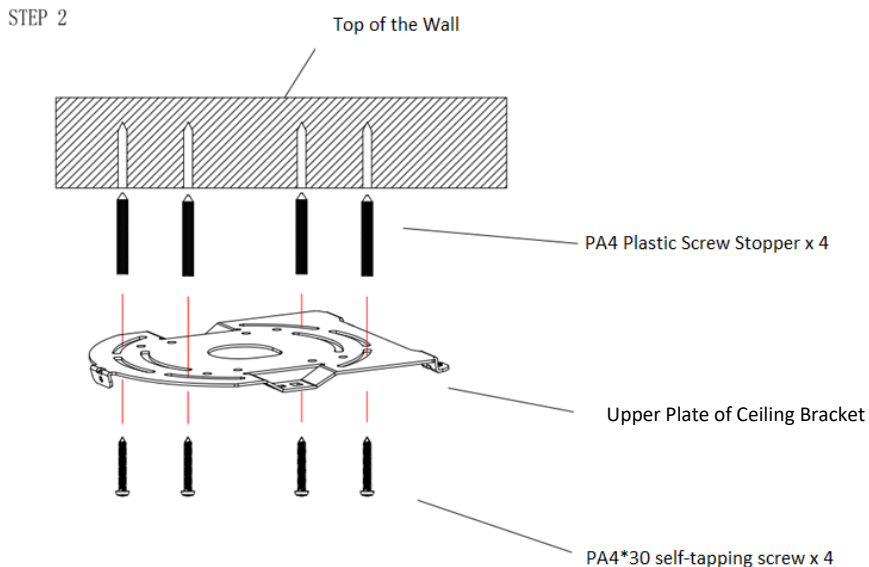

### Step 3: Affix the bracket's lower plate to the bottom of PTC-140T

As depicted in the diagram below, use three PM3\*5 screws to affix the bracket's lower plate to the bottom of PTC-140T.

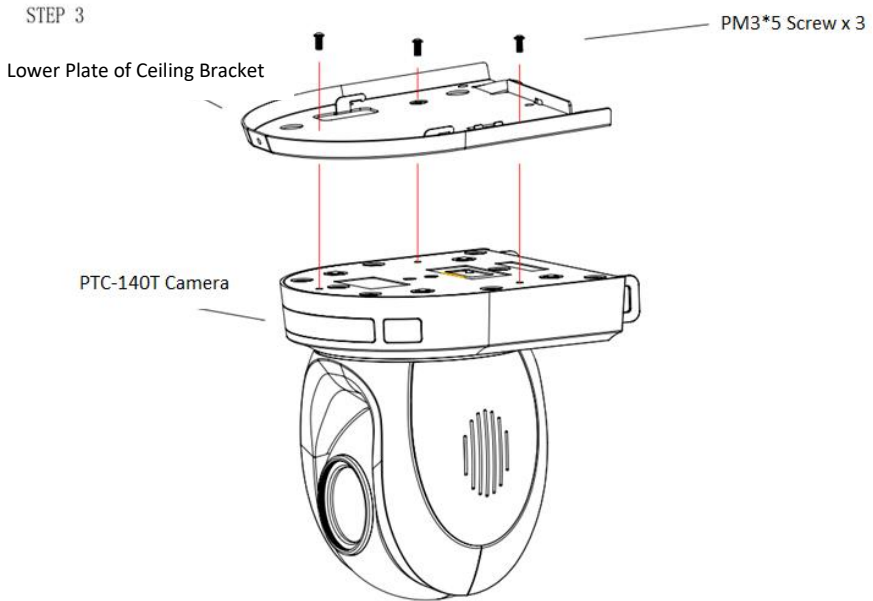

**Step 4: Mount the PTC-140T Camera to the ceiling**

Now push the PTC-140T camera into the bracket's upper plate in the direction as indicated by the arrow in the diagram below. Make sure the two plates click into place.

Finally, secure the PTC-140T camera to the upper plate with three PM3\*5 screws.

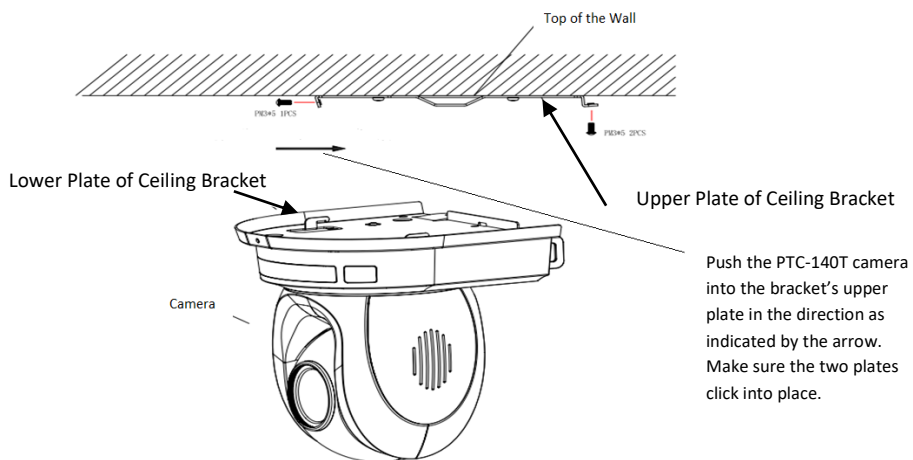

### Step 5: Final

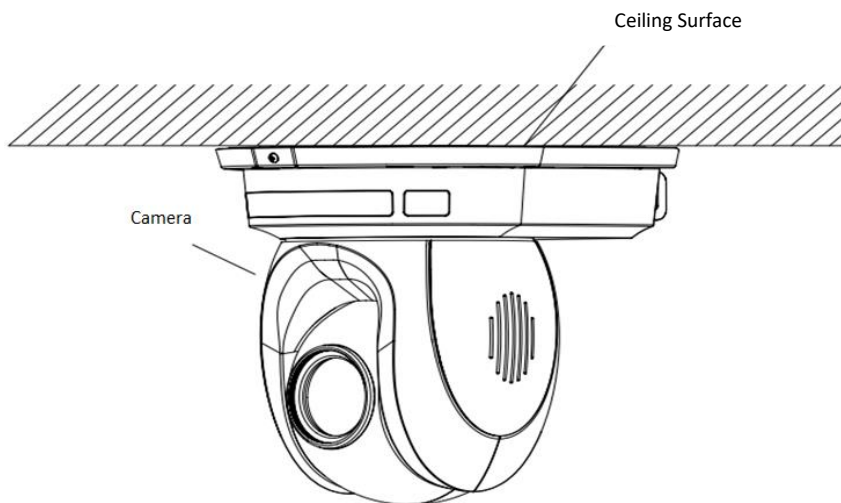

## 6. Network Connection

The Ethernet port on the back panel of your PTC-140T allows you to connect to the PC/Laptop with a static or dynamic IP address. To access and modify these network settings, you will need to log in to the camera's web interface.

If this is your first time using the device, please note that the camera's default IP address is **192.168.5.163**.

Set up direct connection between the camera and your PC/laptop as depicted in the diagram below; remember to manually assign an IP address of **192.168.5.X** to your PC/laptop.

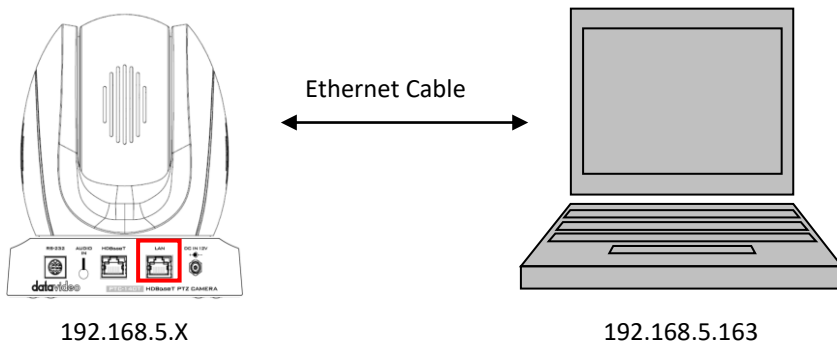

On your PC/laptop, open a web browser and in the address bar, enter the camera's default IP address, 192.168.5.163 then press the **ENTER** key which should take you to login page of the web interface.



**Note: If you have used the PTC-140T somewhere else and the IP address is no longer the default, you can connect the PTC-140T to an external monitor via the receiver box in order to view the camera’s IP address on the connected display. See [Section 2.2 Receiver Box](#) for ways to connect an external monitor.**

The default login credentials are:

- User Name: admin
- Password: admin

After you have successfully logged in to the web interface, you should see the camera video as shown in the diagram below.

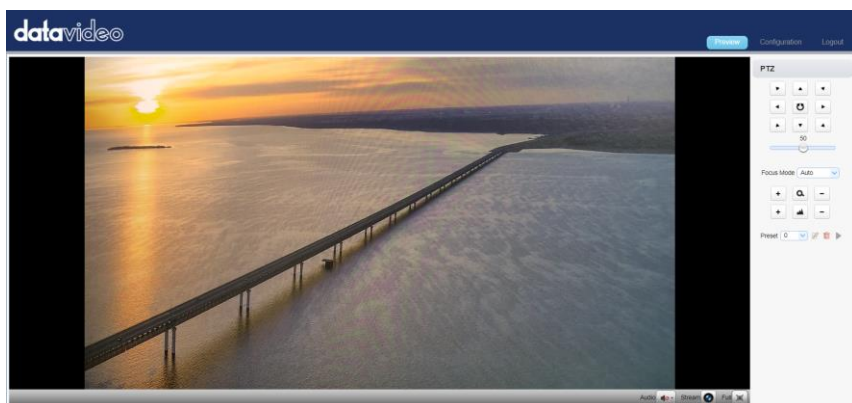

At the top right corner of the web UI, click the Configuration tab to open the Configuration page. On the leftmost pane, click “Network Configure” → “Ethernet” to open the network settings page on which you should be able to see a list of options allowing you to set the camera’s connection mode to DHCP or static IP.

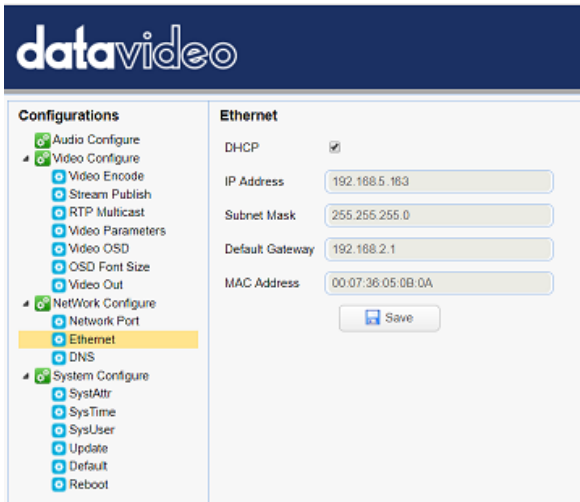

In this chapter, we will show you how to enable DHCP and Static IP modes on PTC-140T in two separate sections.

**Note:** To log out of the web interface, simply click “Logout” at the top right corner of the page.

## 6.1 DHCP Mode

Dynamic Host Configuration Protocol (DHCP) is a network protocol that enables a server to automatically assign an IP address to a network device from a defined range of numbers configured for a given network. The diagram below illustrates a DHCP network connection example.

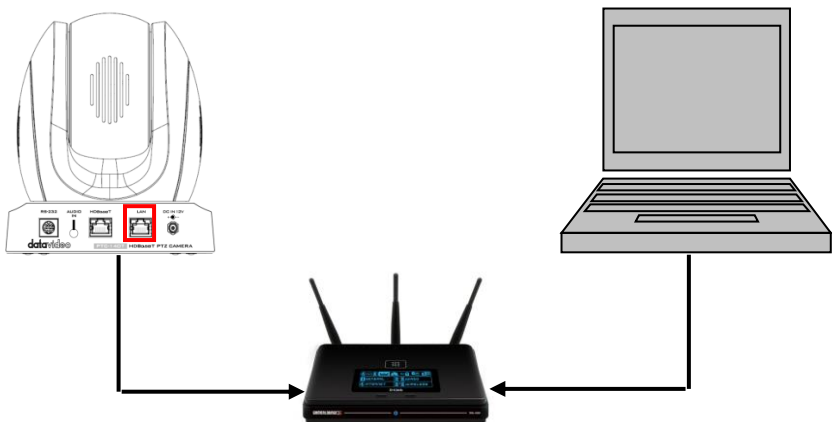

In order to enable the camera's DHCP mode, log in to the web interface and on the leftmost pane, click "Network Configure" → "Ethernet" to open the network settings page on which you should be able to see a list of options allowing you to set the camera's connection mode to DHCP or static IP. Then check the DHCP checkbox to allow the router to dynamically assign an IP address to PTC-140T. Please note that the DHCP option in the OSD menu should also be set to ON.

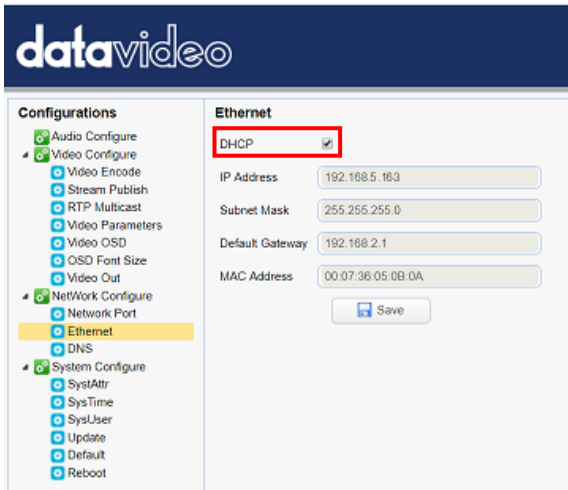

Click the "Save" button to save the new settings then reboot PTC-140T.

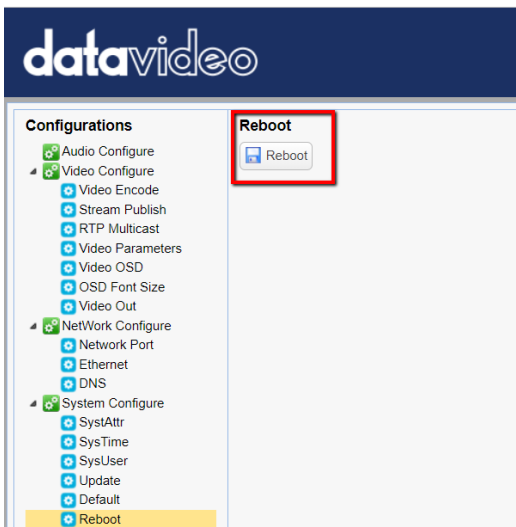



## 6.2 Static IP

A static IP address is a fixed address manually assigned to PTC-140T. First uncheck the DHCP checkbox then enter an IP address for the camera, as well as the subnet mask and the gateway IP.

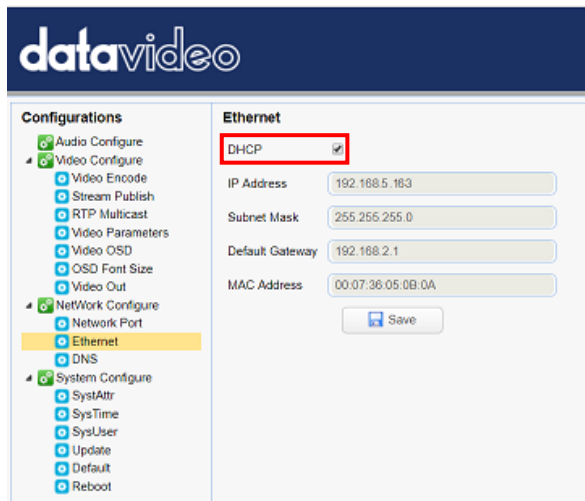

The screenshot shows the 'datavideo' web interface. On the left is a 'Configurations' sidebar with a tree view. Under 'Network Configure', 'Ethernet' is selected. The main area is titled 'Ethernet' and contains a 'DHCP' checkbox (checked and highlighted with a red box), an 'IP Address' field (192.168.5.163), a 'Subnet Mask' field (255.255.255.0), a 'Default Gateway' field (192.168.2.1), and a 'MAC Address' field (00:07:36:05:0B:0A). A 'Save' button is at the bottom.

**Note:** Never assign an address that ends in .0 or .255 as these addresses are typically reserved for network protocols. An address to the very start of the IP pool is also not recommended as it is always reserved for the router.

After you've configured the camera's static IP mode, click the "Save" button to save the new settings then reboot PTC-140T.

## 6.3 DVIP

DVIP is a network configuration software tool designed for DVIP device search on the same network and configuring device network settings such as Hostname, DHCP mode, IP address, subnet mask, gateway IP, and primary and secondary DNS.

Depending on your operating system, download DVIP Configuration Tool from the respective sites listed as follows:

PC: <https://www.microsoft.com/en-us/p/dvip-network-config/9p6gtz839k6s?activetab=pivot%3Aoverviewtab>

Android:

[https://play.google.com/store/apps/details?id=com.datavideo.dvipnetconfig&hl=en\\_US](https://play.google.com/store/apps/details?id=com.datavideo.dvipnetconfig&hl=en_US)

iOS: <https://itunes.apple.com/tw/app/dvip-network-config/id1177895983?mt=8>

After you've installed the DVIP Network Configuration Tool, follow the steps outlined below to scan for online DVIP devices and configure their corresponding settings.

Step 1: Open the DVIP Network Configuration Tool then select your PC or laptop's network interface card from the drop-down menu as shown in the diagram below.



Step 2: The DVIP Network Configuration Tool interface is shown below and you should see a list of the connected cameras.

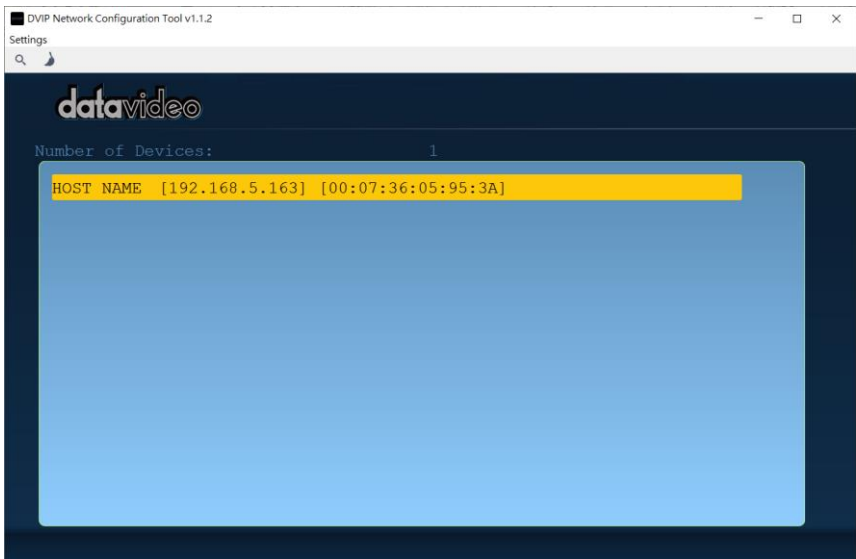

Step 3: Click one of the connected cameras (HOST NAME) to show the device information and its network settings in the pop-up window shown in the diagram below.



Step 4: You are allowed to change the device name in the Host Name field and modify the device's network settings accordingly. To reset, simply click the Default button.

Host Name

Model Name PTC-140  
(VID:0104, PID:3009)

MAC address 00:07:36:05:95:3A

IP address

Using Fixed IP Mode

Mask

Gateway

Primary DNS

Secondary DNS

## 7. Web User Interface

The web based user interface allows you to set and control your PTC-140T devices.

### 7.1 Preview

In preview, you will be able to see the camera image in real time as shown in the diagram below. Click on the preview window once to view in full screen mode and click again to exit.

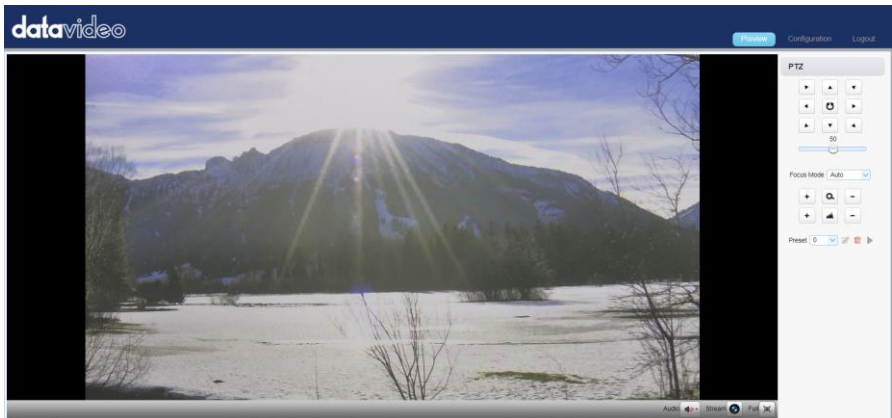

At the bottom right corner of the camera image display window, you should find three buttons, namely, Stream, Audio and Full, which are described below:



Click the “**Stream**” button to switch between Main Stream and Sub Stream previews. See **Video Encode** in **Configuration** tab for stream settings.



Click the “**Audio**” button to turn ON/OFF the sound. See **Audio Configure** for audio settings.









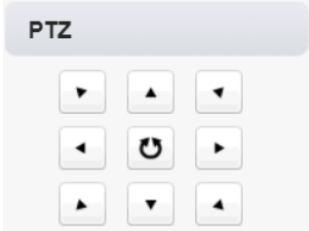

Click the “**Full**” button to switch to the full screen display mode.

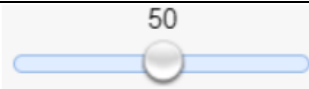
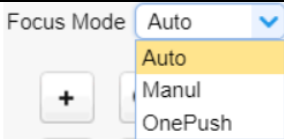
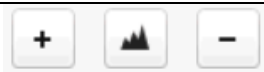
**Note: Only H.264 BP and MP video streams can be viewed on the Preview window. H.264 HP and H.265 video streams CANNOT be viewed on the Preview window.**

## Control Functions





Further to the right, there are various control functions, such as **PTZ control**, **PTZ speed slider**, **focus mode** drop-down menu, **zoom** and **focus** controls, as well as **presets** for saving PTZ settings. Details of each will be described in the table below.

Controls	Descriptions
	<p><b>PTZ Control Buttons</b></p> <p>Click the arrow buttons to move the camera head to corresponding directions.</p> <p>To return to <b>Home</b> position, click  .</p>
	<p><b>PTZ Speed Slider</b></p> <p>The PTZ speed slider adjusts the P/T speed, ranging from 0 (slowest) to 100 (fastest). The default speed is 50. Slide right to increase the speed and left to decrease.</p>
	<p><b>Focus Mode</b></p> <p>Select focus mode from the drop-down menu; available options are <b>Auto</b>, <b>Manual</b> and <b>One Push</b>.</p> <p><b>Auto:</b> Automatic focus</p> <p><b>Manual:</b> Manual focus</p> <p><b>One Push:</b> One time automatic focus.</p>
	<p><b>Focus Far/Near</b></p> <p>Click  (FAR) and  (Near) buttons accordingly to manually focus the camera lens onto the subject.</p> <p><b>Note: You will not be able to manually adjust the camera focus if focus mode is set to Auto or One Push.</b></p>

Controls	Descriptions
	<p><b>Zoom IN/OUT</b></p> <p>Click  to zoom in and  to zoom out.</p>

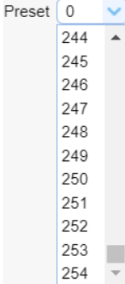
## Preset

The presets allow you to save multiple PTZ settings to the camera. See function descriptions in the table below.

Functions	Descriptions
	<p><b>Preset Drop-Down Menu</b></p> <p>Select a preset number from the drop-down menu.</p> <p><b>Note: There are 255 presets ranging from 0 – 254.</b></p>
	<p><b>Set Button</b></p> <p>Click <b>Set</b> button to save PTZ settings to the selected preset number.</p>
	<p><b>Delete Button</b></p> <p>Click <b>Clear</b> button to remove PTZ settings from the selected preset number.</p>
	<p><b>Run Button</b></p> <p>Click <b>Run</b> button to recall PTZ settings from the selected preset number.</p>

## Set the Preset

To set the preset, follow the steps outlined below.

1. First adjust the camera head to the desired **pan** and **tilt** positions.
2. Make sure **zoom** and **focus** are adjusted as well.
3. Select a preset number from the **Preset** drop-down menu.
4. Click the Set button to save the PTZ settings to the selected preset number.

## Recall the Preset

To recall a saved preset, simply select a preset number from the **Preset** drop-down menu then click the Run button to apply the saved settings.

## 7.2 Configuration

In **Configuration**, you will be able to configure the camera's audio, video, network and system settings which will be described further in the next few sections.

### Audio Configure



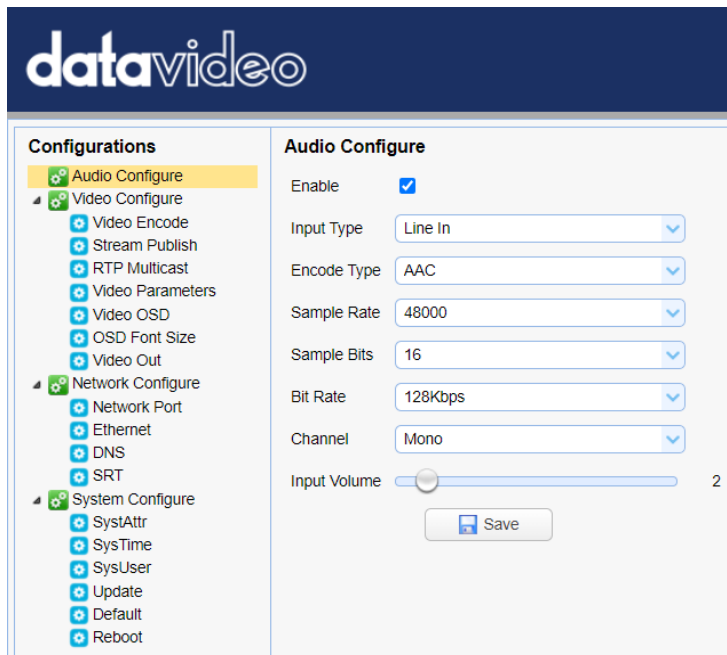

Audio Configure allows you to configure the input audio source.



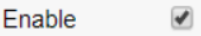

The screenshot displays the DataVideo configuration interface. At the top, the 'datavideo' logo is visible. The interface is divided into two main sections: 'Configurations' on the left and 'Audio Configure' on the right. The 'Configurations' section contains a tree view with the following items: Audio Configure (selected), Video Configure (expanded), Network Configure (expanded), and System Configure (expanded). Under 'Video Configure', there are sub-items: Video Encode, Stream Publish, RTP Multicast, Video Parameters, Video OSD, OSD Font Size, and Video Out. Under 'Network Configure', there are: Network Port, Ethernet, DNS, and SRT. Under 'System Configure', there are: SystAttr, SysTime, SysUser, Update, Default, and Reboot. The 'Audio Configure' section contains the following settings: 'Enable' is checked; 'Input Type' is set to 'Line In'; 'Encode Type' is set to 'AAC'; 'Sample Rate' is set to '48000'; 'Sample Bits' is set to '16'; 'Bit Rate' is set to '128Kbps'; 'Channel' is set to 'Mono'; and 'Input Volume' is a slider set to approximately 2. A 'Save' button is located at the bottom of the 'Audio Configure' section.

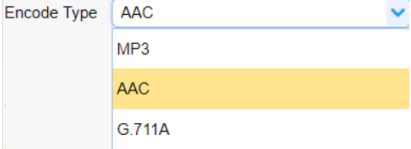
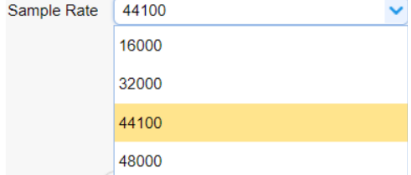

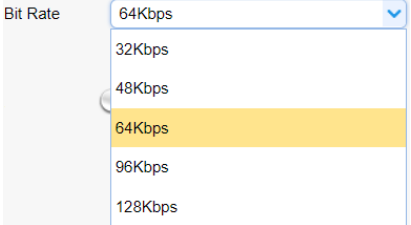
See the table below for descriptions of each item.

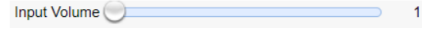
Items	Descriptions
	<p><b>Enable</b> Check this checkbox to enable audio settings.</p>
	<p><b>Input Type</b> This allows users to select the audio input type. It provides Line IN for the audio input type.</p>
	<p><b>Encode Type</b> Select an encode type for your input audio source. The available encode types include MP3, AAC and G.711A.</p>
	<p><b>Sample Rate</b> Select a sample rate for your input audio source. The higher the sample rate, the better the audio quality.</p>
	<p><b>Sample Bits</b> Select the sample bits for your input audio source. The default is 16.</p>
	<p><b>Bit Rate</b> Select a bit rate for your input audio source. Available bit rates are:</p> <ul style="list-style-type: none"> <li>• 32 Kbps</li> <li>• 48 Kbps</li> <li>• 64 Kbps</li> <li>• 96 Kbps</li> <li>• 128 Kbps</li> </ul>

Items	Descriptions
	<b>Channel</b> Set your input audio source to <b>Mono</b> .
	<b>Volume Slider</b> Adjust the volume of your input audio source using the volume slider (Min: 1 / Max: 10).
	<b>Save Button</b> Click the Save button to save the new audio settings.

## Video Configure

Video Configure allows you to configure the input video source.

### Video Encode

In **Video Encode**, you will be able to configure the video quality for main and sub streams. See the diagram below for various video settings.

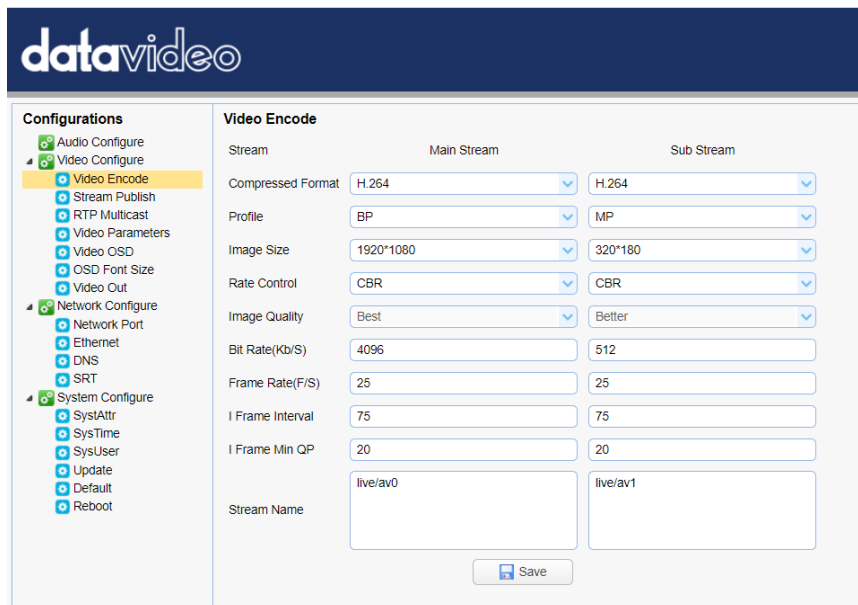

See the table below for descriptions of each item.

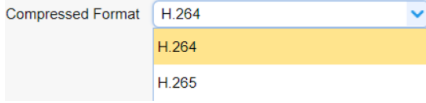
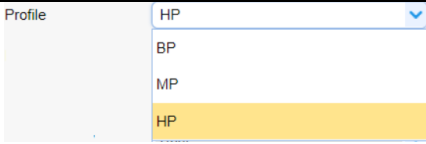
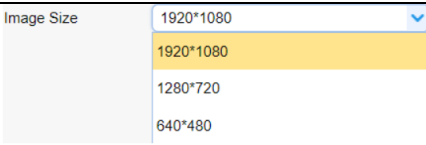
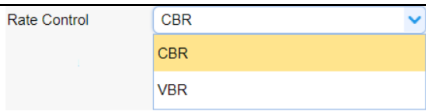
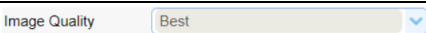
Items	Descriptions
<p>Compressed Format</p> 	<p><b>Compressed Format</b>            Select either <b>H.264</b> or <b>H.265</b> video compression.</p>
<p>Profile</p> 	<p><b>Profile</b>            Select a profile for your input video source. Available profiles are:</p> <ul style="list-style-type: none"> <li>• <b>BP: Baseline Profile (Default)</b></li> <li>• <b>MP: Main Profile</b></li> <li>• <b>HP: High Profile.</b></li> </ul>
<p>Image Size</p> 	<p><b>Image Size</b>            Select an appropriate image size from the drop-down menu.</p> <ul style="list-style-type: none"> <li>• 1920 x 1080</li> <li>• 1280 x 720</li> <li>• 640 x 480</li> </ul>
<p>Rate Control</p> 	<p><b>Rate Control</b>  <b>CBR</b> encoding does not optimize media files for quality but will save you storage space. <b>VBR</b> takes longer to encode but produces the most favorable results as the quality of the media file is superior.</p>
<p>Image Quality</p> 	<p><b>Image Quality</b>            The default image quality for the main stream is “<b>Best.</b>”             The default image quality for the sub stream is “<b>Better.</b>”</p>

<p>Bit Rate(Kb/S) <input type="text" value="4096"/></p>	<p><b>Bit Rate</b>  A bitrate is the amount of data required to encode a single second of video. From a streaming perspective, the higher the bitrate, the higher the quality, and the more bandwidth it will require.</p> <p>The default bit rate for the main stream is “<b>4096 Kb/s.</b>”</p> <p>The default bit rate for the sub stream is “<b>512 Kb/s.</b>”</p>
<p>Frame Rate(F/S) <input type="text" value="25"/></p>	<p><b>Frame Rate</b>  Higher frame rate will result in smooth video viewing experience. The frame rate is <b>25</b> by default.</p>
<p>I Frame Interval <input type="text" value="75"/></p>	<p><b>I Frame Interval</b>  A shorter I Frame Interval results higher quality video but consumes more network bandwidth. On the other hand if longer I Frame Interval is set, less bandwidth will be required but it will result in lower video quality. I frame interval is <b>75</b> by default.</p>
<p>I Frame Min QP <input type="text" value="20"/></p>	<p><b>I Frame Min QP</b>  A low QP value means less compression but higher video quality. The default value is <b>20</b>.</p>
<p>Stream Name <input type="text" value="live/av0"/></p>	<p><b>Stream Name</b>  Enter a stream name for the main and sub stream.</p>
<p></p>	<p><b>Save Button</b>  Click the Save button to save the new video settings.</p>

## Stream Publish

In **Stream Publish**, you will be able to configure the RTSP, RTMP or SRT settings for main and sub streams. See the diagram below for various RTSP, RTMP or SRT settings.

See the table below for descriptions of each item.

Items	Descriptions
<p><b>Enable</b> <input checked="" type="checkbox"/></p>	<p><b>Enable</b> Check this checkbox to enable RTMP stream.</p>
<p>Protocol Type <input type="text" value="SRT"/></p> <ul style="list-style-type: none"> <li>RTSP</li> <li>RTMP</li> <li style="background-color: yellow;">SRT</li> </ul>	<p><b>Protocol Type</b> The three available streaming protocols are <b>RTSP</b>, <b>RTMP</b> and <b>SRT</b>.</p>
<p>Host Address <input type="text" value="rtmp://a.rtmp.youtube.com/live2"/></p>	<p><b>Host Address</b> This is the RTMP/RTSP Server URL provided by video streaming service providers. An example of the RTMP Server URL is provided.</p>

Items	Descriptions
Host Port <input type="text" value="1935"/>	<b>Host Port</b> The host port number is 1935 by default.
Stream Name <input type="text" value="live2/qwqd-5ejj-t73c-0y2g"/>	<b>Stream Name</b> This is the RTMP/RTSP Stream Name/Key provided by video streaming service providers. An example of the RTMP Stream Name/Key is provided.
User Name <input type="text"/> Password <input type="text"/>	<b>User Name / Password</b> Enter the login credentials of the RTSP or RTMP streaming platform.
Password for stream encryption <input type="password" value="....."/>	<b>Password for Stream Encryption</b> Enter a password for the SRT stream.
Crypto key length in bytes <input type="text" value="32"/> <input type="text" value="0"/> <input type="text" value="16"/> <input type="text" value="24"/> <input type="text" value="32"/>	<b>Crypto Key Length (Bytes)</b> Select an appropriate key length to protect the SRT stream from attacks. You can select 0, 16, 24 or 32 bytes.  <b>Note: A 0 byte key means no encryption applied to the SRT stream.</b>
	<b>Save Button</b> Click the Save button to save the new RTMP settings.

**Notes:**

- 1. The SRT Caller and RTSP Publish modes can only function as the Main Stream encoder.**
- 2. The Sub Stream will be disabled when the SRT Caller or the RTSP Publish functions as the Main Stream encoder.**

## Stream to Youtube

In this section, we will show you how to set up an **RTMP(S)** stream to **Youtube**. The step-by-step setup is outlined as follows:

1. First of all, you have to obtain Server URL and Stream Name/Key from Youtube.
2. Open the Youtube Live Dashboard  
[https://www.youtube.com/live\\_dashboard](https://www.youtube.com/live_dashboard)
3. On the left column, locate and click **“Stream now.”**

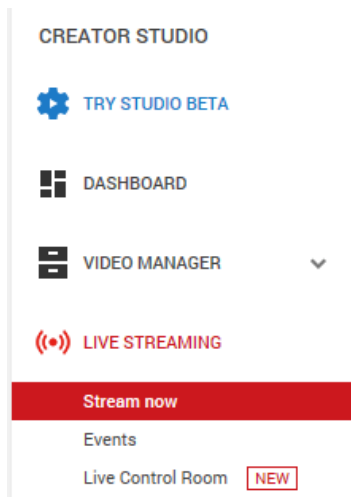

4. On the right, scroll down to the bottom where you will be able to find **Server URL** and **Stream name/key**.

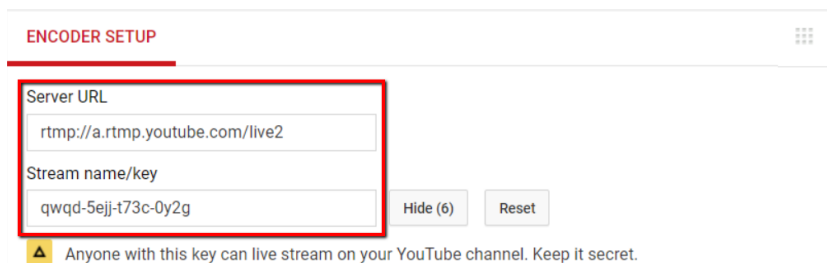

5. Open the PTC-140T’s web UI and click **“Video Configure”** → **“Stream Publish”**.

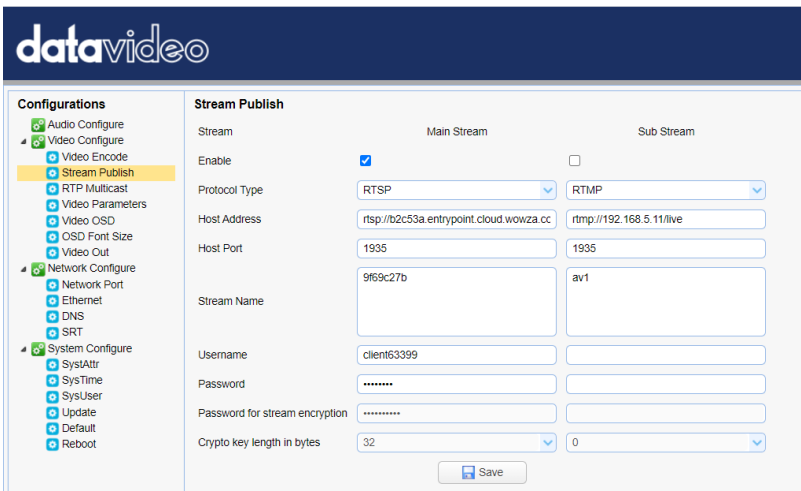

6. Enter the **Server URL** and **Stream Name/Key** into **Host Address** and **Stream Name** respectively.
7. Check the **Enable** checkbox to enable RTMP stream.
8. Click the **Save** button to save the RTMP settings and reboot (System Configure → Reboot) the camera to apply the new settings then you can start broadcasting your camera video on Youtube.

### Stream to Facebook

In this section, we will show you how to set up an **RTMP(S)** stream to **Facebook**. The step-by-step setup is outlined as follows:

1. Go to the “[How to go live on Facebook with a camera and streaming software](#)” website by clicking the link below or enter the link address into the address bar of your browser then hit the ENTER key.

Link: <https://www.facebook.com/formedia/solutions/facebook-live>

Click “**Live Producer**” or “[facebook.com/live/producer](https://www.facebook.com/live/producer)” on the page shown below to start the stream setup.

**Note: Facebook Live limits each stream to 8 hours.**



Facebook Live    How to Go Live    Tools & Features    Raise Money for a Cause    Broadcast with Guests    Online Events    Grow & Earn Money    Our Streaming Partners

## How to go live on Facebook with a camera and streaming software

Utilize a streaming software.

You'll first need to get set up with streaming software, also referred to as encoding software or an encoder. The encoder that's best for you may depend on the type of content you plan to stream. There are several programs to choose from, including free open-source software. Learn more about encoding software options and going live with streaming software.

Use Live Producer.

Once you have your encoding software and camera installed, you're ready to go live using **Live Producer**, which is the new way to go live on Facebook using higher-end production equipment and streaming software. You can access Live Producer at [facebook.com/live/producer](https://facebook.com/live/producer).

Learn more about going live.

Learn more about how to use Live Producer here. If you're planning a larger virtual event or show, we also recommend checking out



Alternatively, you can also click the Live Video tab on your personal Facebook page to start the stream setup.

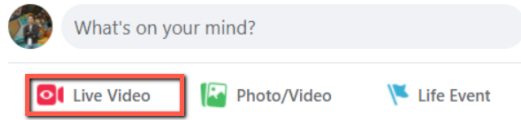

2. Click the “Use Stream Key” tab then locate “Server URL” and Stream Key”.

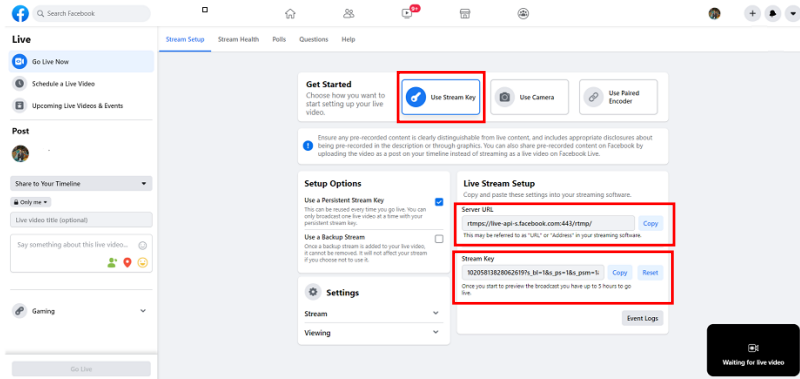

3. Open the PTC-140T’s web UI and click “Video Configure” → “Stream Publish”

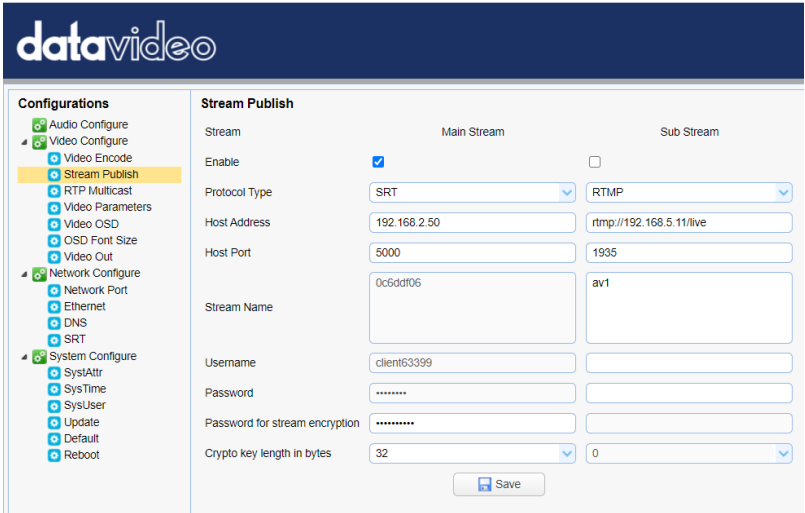

4. Enter the **Server URL** and **Stream Key** into **Host Address** and **Stream Name** respectively. Enter 443 into the “Host Port”.
5. Check the **Enable** checkbox to enable RTMP stream.
6. Click the **Save** button to save the RTMP settings and reboot (“**System Configure**” → “**Reboot**”) the camera to apply the new settings.
7. After the camera is successfully rebooted, you will see a preview screen appearing at the bottom right corner of the Facebook Live page as shown below.

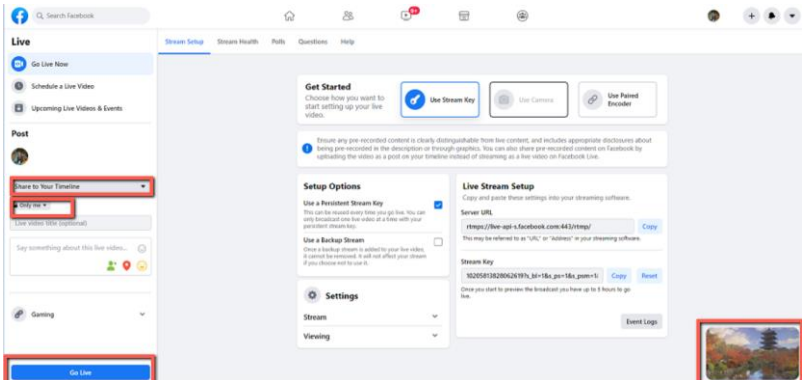
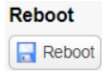

- On the left of the page, first select where you want to stream your live camera video to then select your audience. Finally, enter the title of the live stream and click the **“Go Live”** button to start the stream.
- As soon as the live stream is started, you will be able to view the live camera video on the Facebook Live page. To end, simply click the **“End Live Video”** button.

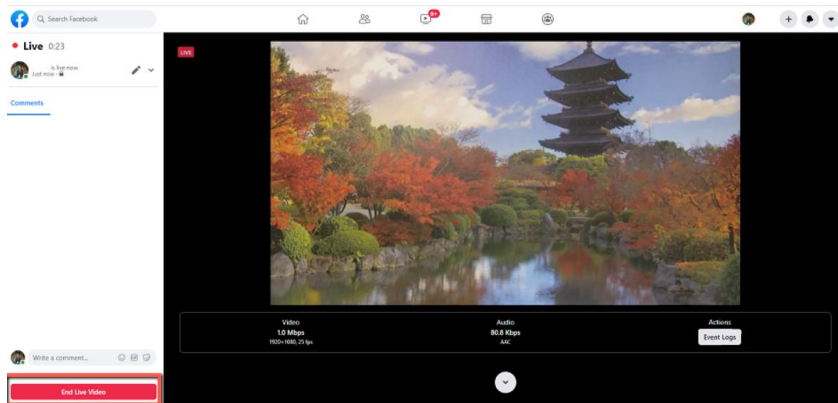

### Stream via RTSP to Wowza Streaming Cloud

Wowza Streaming Cloud allows you to easily stream live video to any device. In this section, we will show you how you can stream the PTC-140T camera video to Wowza Streaming Cloud via RTSP.

- First open Wowza’s official website ([www.wowza.com](http://www.wowza.com)) shown below.

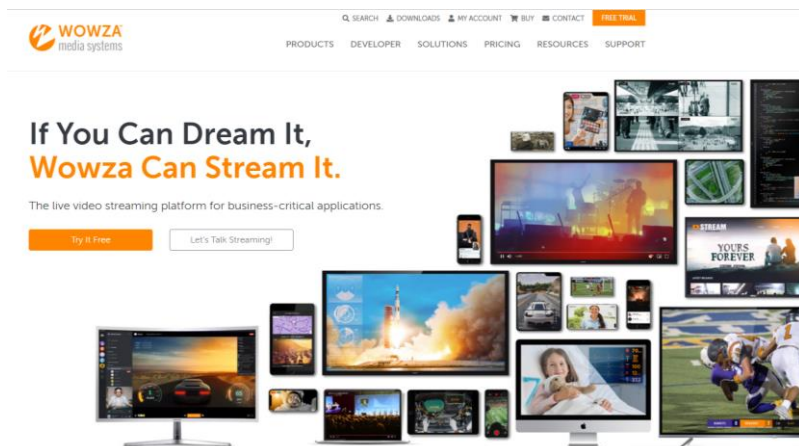

2. Click “MY ACCOUNT” to log in to your Wowza account.

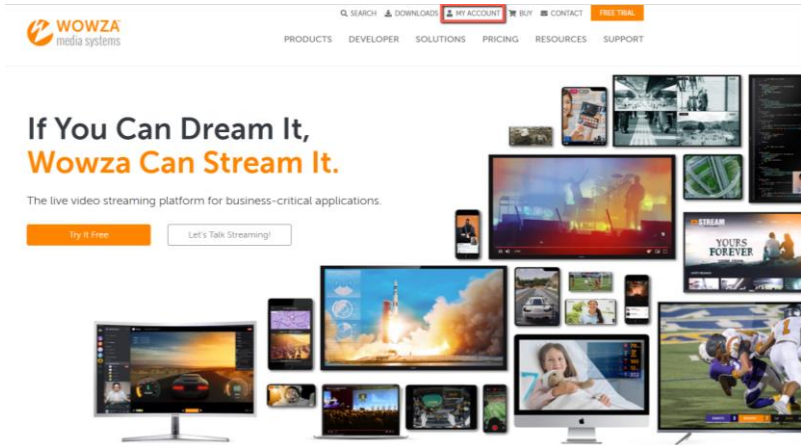

3. If you already have a Wowza account, simply log in with your email address. If you do not have a Wowza account, apply for a 30 day trial account.

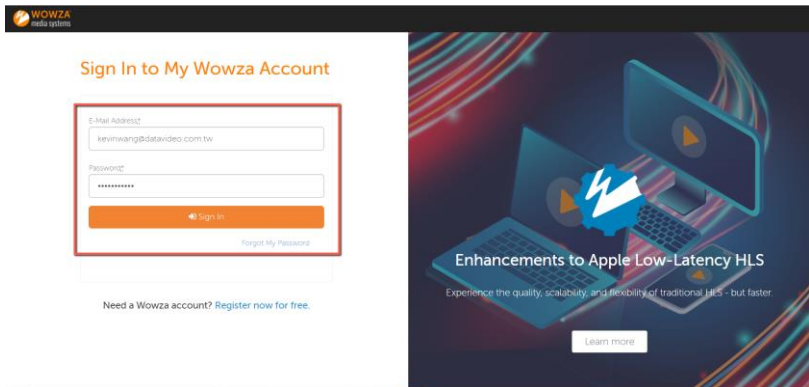

4. We will be using the free trial account in this example, so after login, on the page that opens, click the **FREE TRIAL** button located at the top right corner.

## My Account

**Info** Payment Options Orders Support Products Wowza Cloud StreamLock

Info [\(edit\)](#)

Account Email: kevinwang@datavideo.com.tw  
Company: Datavideo

### Contact Information

To change your email address or company name, please contact us.

First Name	Kevin
Last Name	Wang

### Password

To change your password, [request a password reset](#).

5. As shown below, click the Free Trial button of Wowza Streaming Cloud.

## Select a Wowza Free Trial

### Wowza Streaming Cloud

Fully managed cloud service to power live streaming, either end-to-end or as part of a custom streaming platform.

Your free trial includes:

- Fully managed infrastructure.
- Free player and hosted page.
- REST API, Java SDK, and Ruby SDK access.
- 5 hours streaming / 10 connections.

**BEST FOR**

- Deploying quickly on a managed infrastructure
- Live event streaming to web or social sites
- Building live-streaming apps via GUI or API

**Free Trial**

[Are you a developer? Get a Wowza Streaming Cloud Developer Trial](#)

### Wowza Streaming Engine

Downloadable server software for live and on-demand streaming: on-premises or in the cloud, fully customizable.

Your free trial includes:

- Windows, Mac, or Linux install.
- Transcoder, nDVR, and more.
- REST and Java API access.
- StreamLock-provisioned SSL certificate for HTTPS and WebRTC streaming
- 3 inbound / 10 outbound connections.

**BEST FOR**

- Self-managed infrastructures
- Streaming service providers
- Customized streaming solutions

**Free Trial**

[Are you a developer? Get a Wowza Streaming Engine Developer Trial](#)

6. Click the “Launch Wowza Streaming Cloud” button.

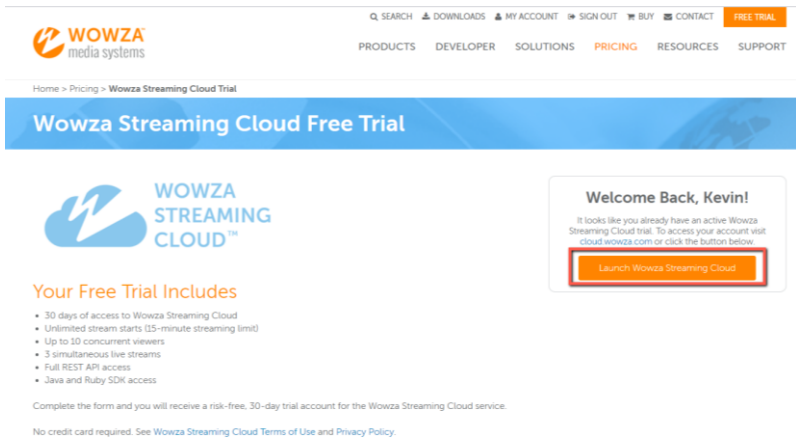

7. The UI of Wowza Streaming Cloud is shown in the diagram below. Click “Add Live Stream” to create a live stream channel.

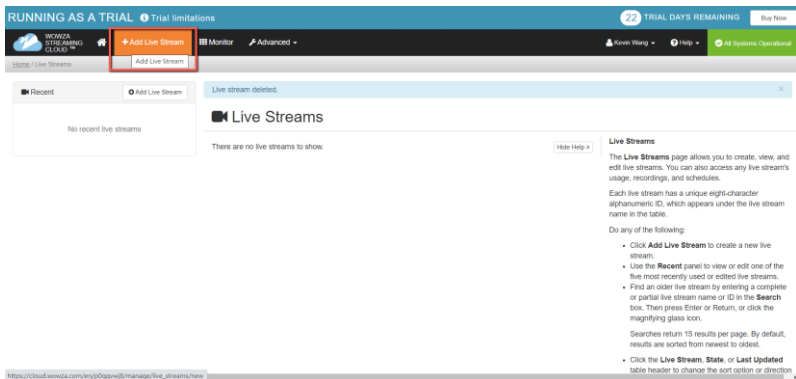

8. Enter a name for this live stream. As shown in the diagram below, we will use RTSP Stream in this example.

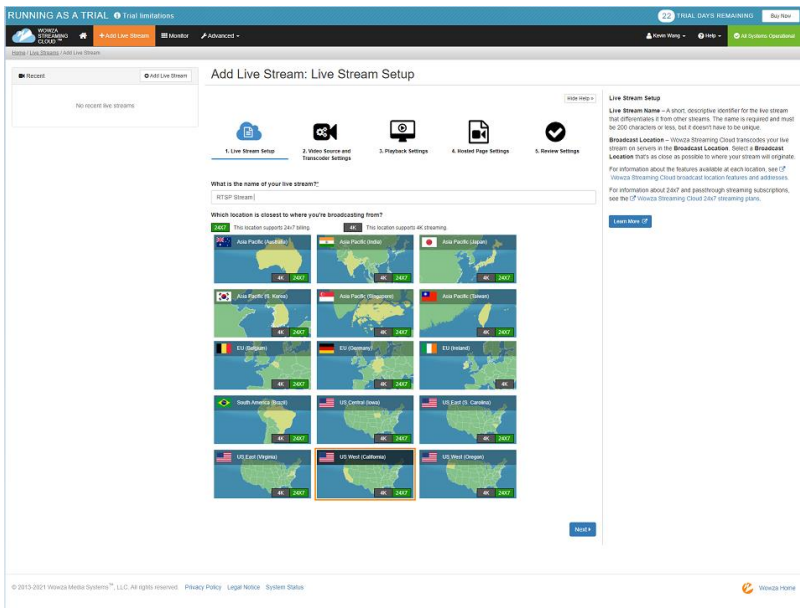

9. Select a location that is nearest to you. In this example, we will select “Asia Pacific Taiwan”, then click the Next button.

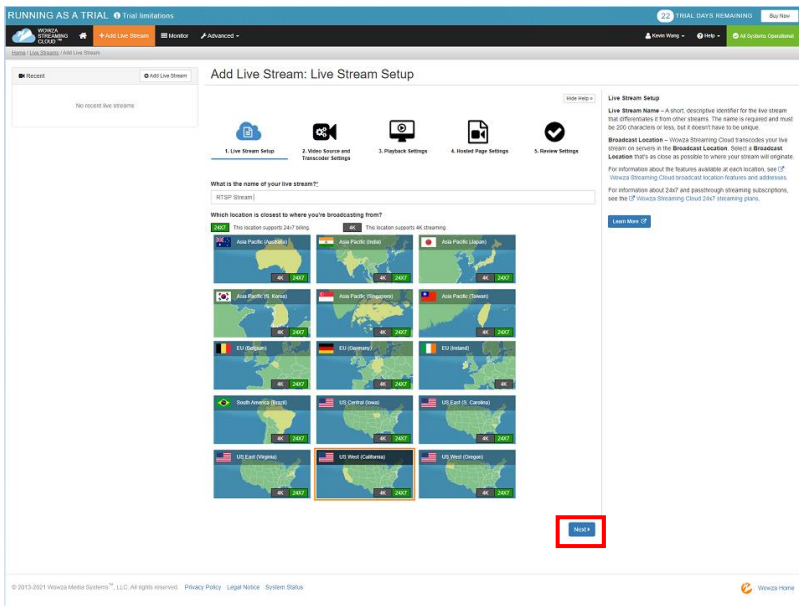

- Select the camera or the encoder that you want to use to connect to Wowza Streaming Cloud. This example uses RTSP so click “Other RTSP” as shown in the diagram below. The rest of the options can be kept as default values. Finally, click the “Next” button.

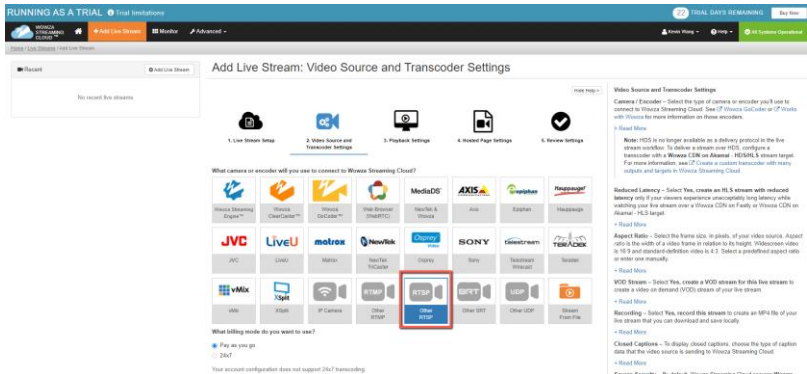

What billing mode do you want to use?

- Pay as you go
- 24x7

Your account configuration does not support 24x7 transcoding.

What type of live stream is this?

- Adaptive bitrate
- Passthrough

Your account configuration does not support Pay-As-You-Go passthrough transcoding.

Do you want to push or pull your stream?

Select *Push Stream* if your camera or encoder will push the stream to Wowza Streaming Cloud  
Select *Pull Stream* if your camera or encoder requires Wowza Streaming Cloud to pull the stream

Do you want to create a reduced-latency HLS stream?

- Yes, create an HLS stream with reduced latency

Select this option only if viewers experience unacceptably long latency and you understand that playback might be affected on some older devices.

Aspect Ratio: 16:9 (Widescreen)

x

This setting creates 5 bitrate renditions.

Do you want to create a VOD stream for this live stream?

- Yes, create a VOD stream for this live stream

Do you want to record this live stream?

- Yes, record this live stream

What type of closed captions does this stream have?

Source Security

- Disable authentication

Select to disable authentication on the video source



11. Configure your player on this page. Click “Next” after it’s done.

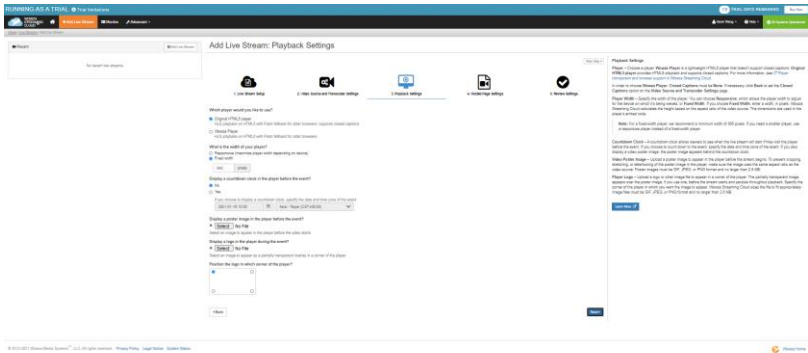

12. On the Hosted Page setup page, enter the page title then click Next.

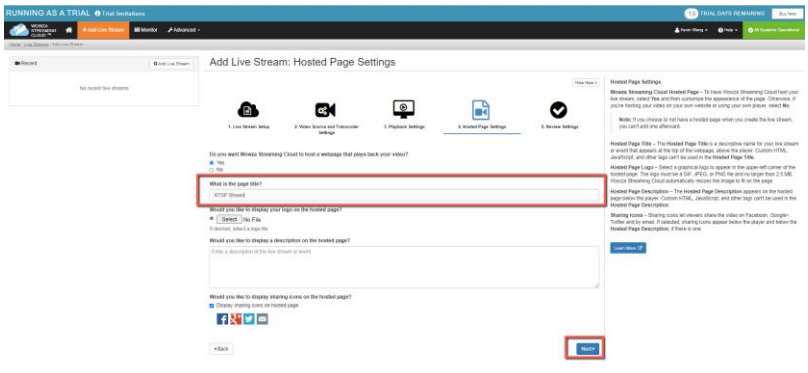

13. Check your live stream setup and click Finish if all settings are correct.

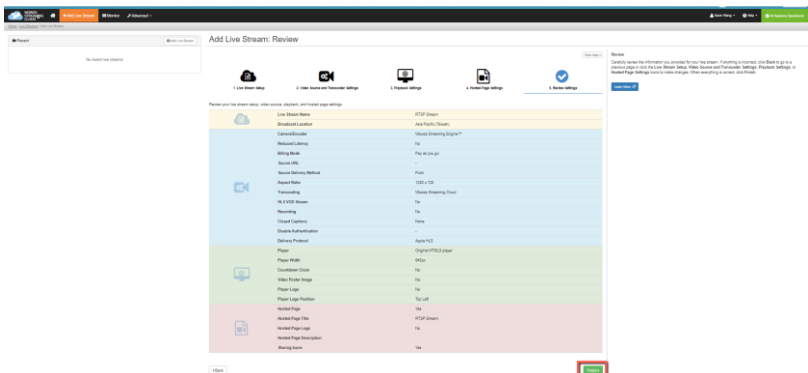

14. Set up the RTSP encoder on the PTC-140T.

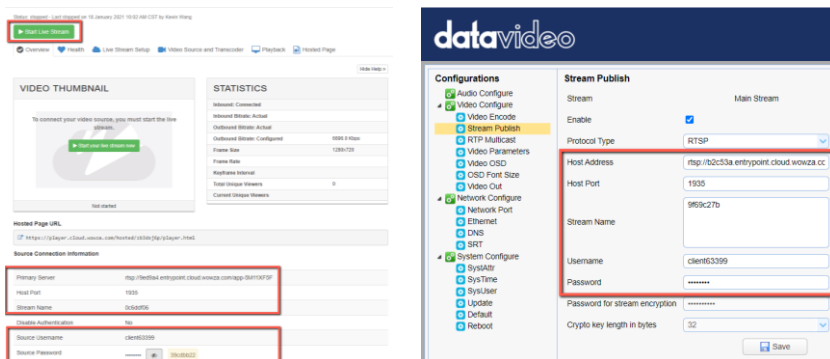

Replicate the following source connection information provided by Wowza to the corresponding fields of the RTSP encoder on your PTC-140T.

Source Connection Information	RTSP Encoder (PTC-140T)
Primary Server	Host Address
Host Port	Host Port
Stream Name	Stream Name
Source Username	Username
Source Password	Password

After all fields are entered with the respective information, click the **Save** button to save the RTSP settings and reboot (System Configure → Reboot) the camera to apply the new settings.

15. Finally, click the “Start Live Stream” button and you should see the prompt message below. Click Start.

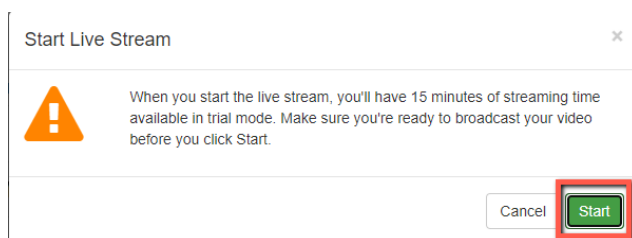

16. As shown in the diagram below, your PTC-140T camera video is now successfully being streamed to Wowza Streaming Cloud via RTSP.

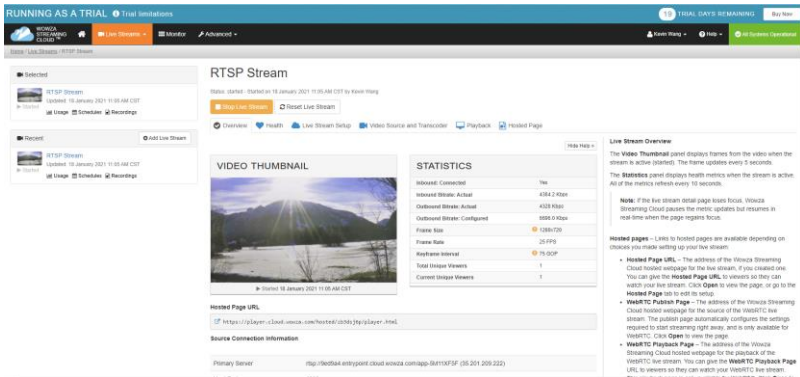

## SRT Streaming using the vMix Software

In this section, we will show you how you can stream your camera video via SRT using the vMix Software.

### Install the vMix Software

Follow the steps outline below to install the vMix software.

1. Download the 60 day free trial version from the vMix official website to your PC or laptop.

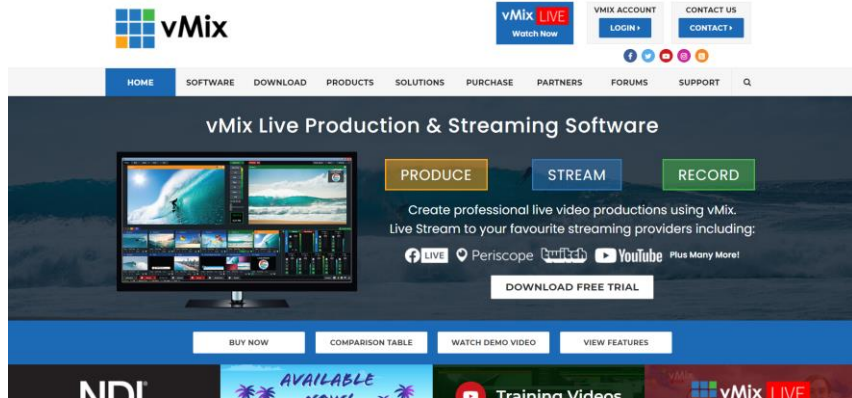

2. Double click the installer icon (vmix23.exe).
3. Click Next.

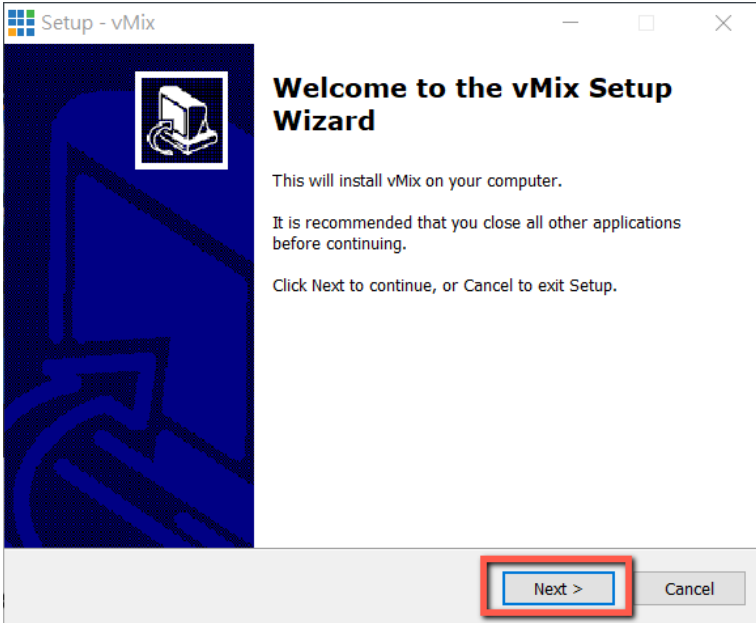

4. Accept the agreement then click Next.

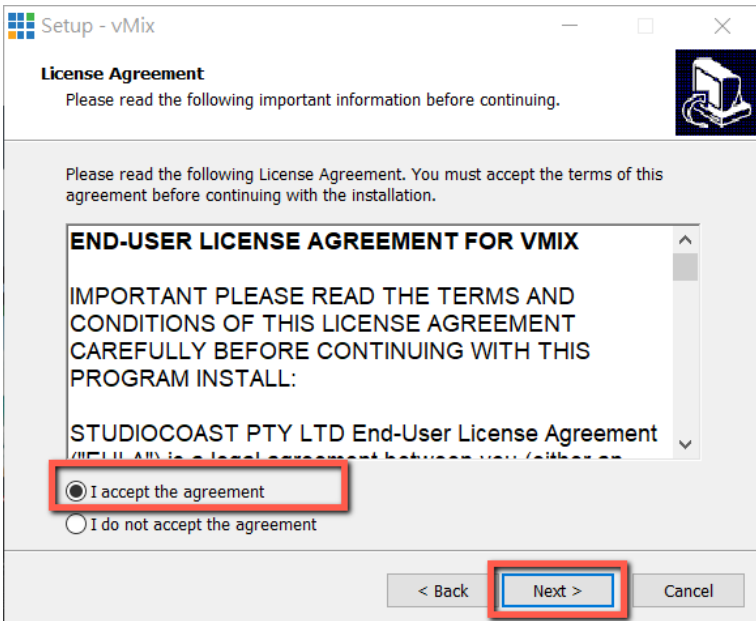

5. Click Next.

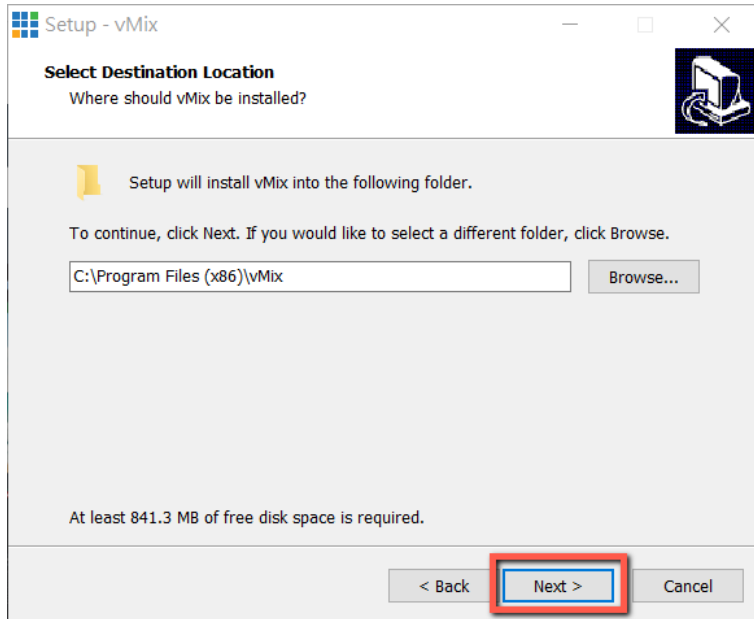

6. Click Next.

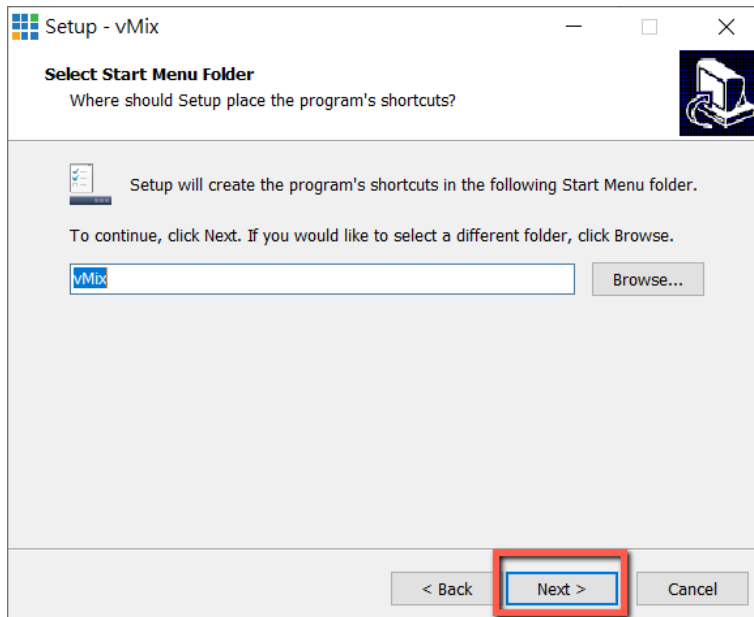

7. Click Next.

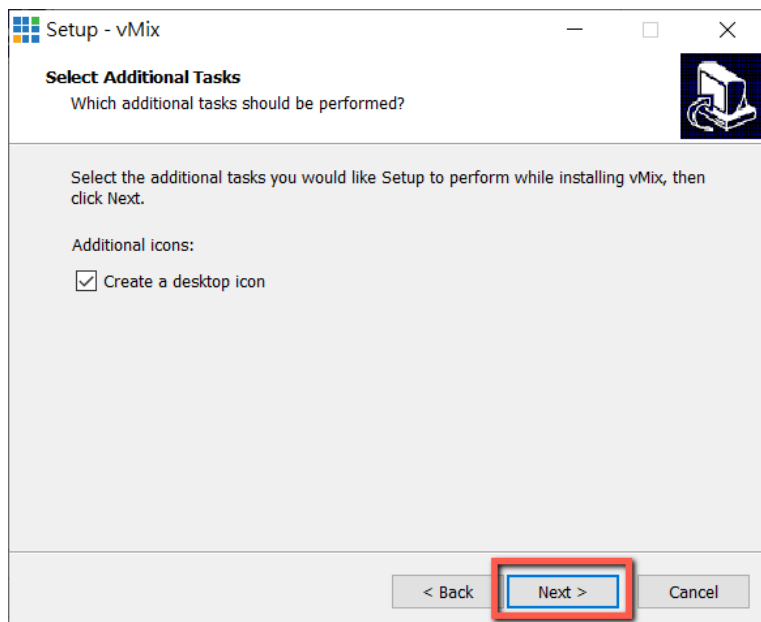

8. Click Next.

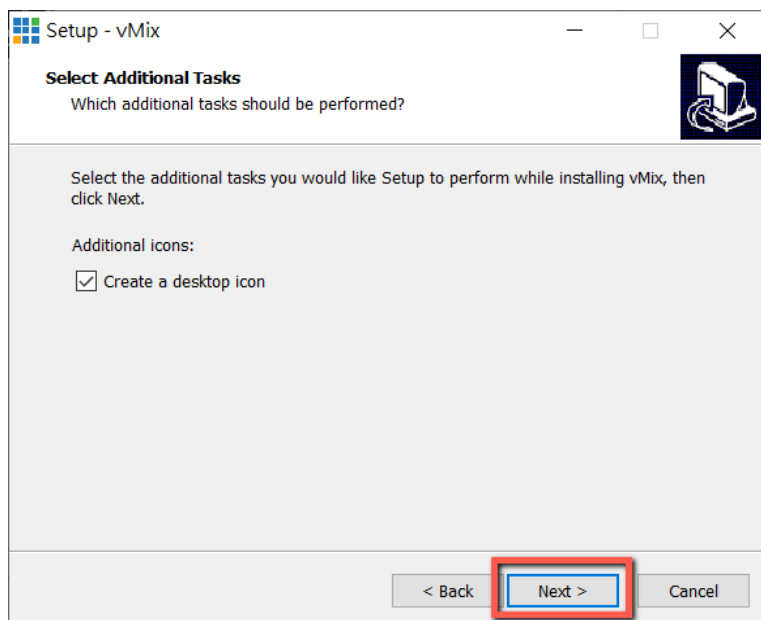

## 9. Installing

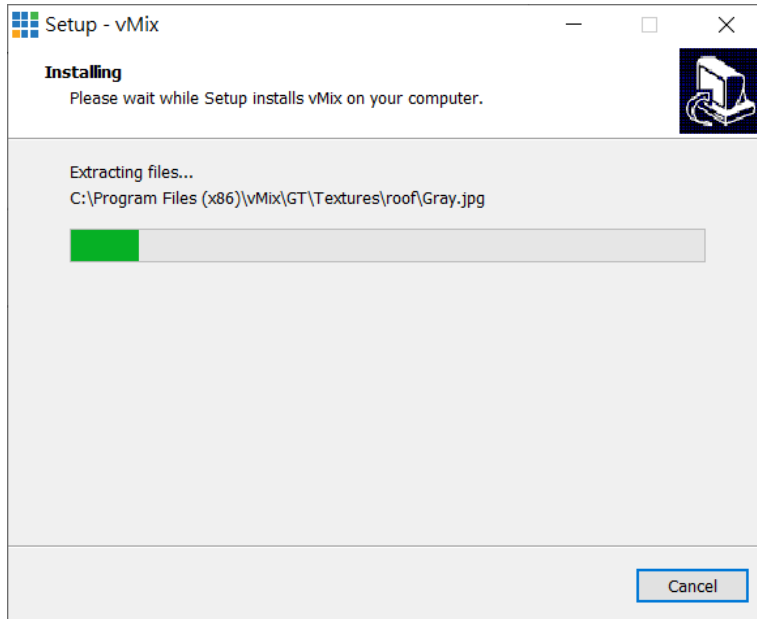

## 10. Click Finish to complete the setup.

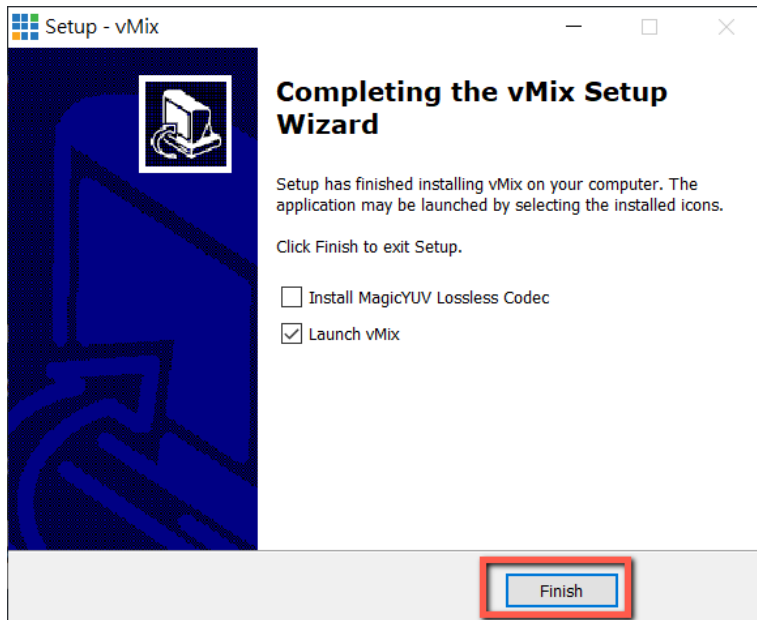

- Remember to register for a fully functional 60 Day Trial with your e-mail address. After that, click OK.

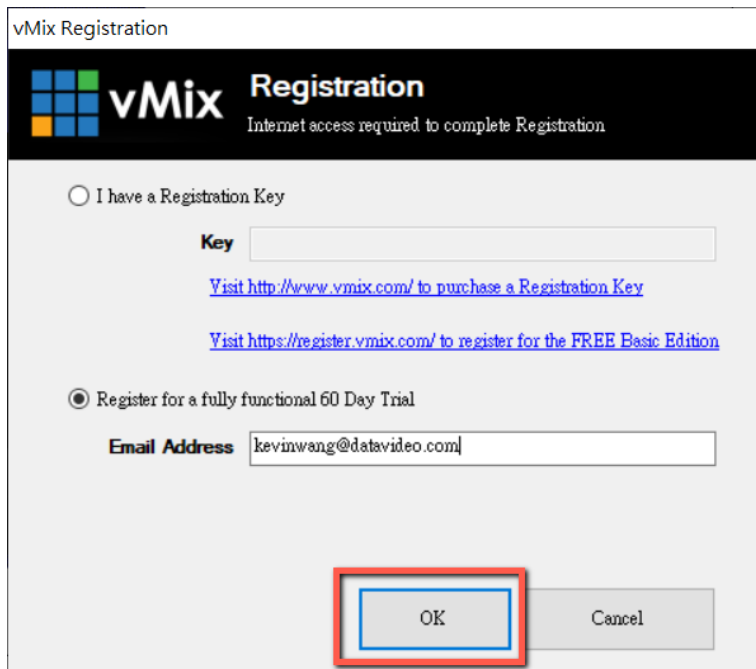

vMix Registration

**vMix Registration**  
Internet access required to complete Registration

I have a Registration Key

**Key**

[Visit http://www.vmix.com/ to purchase a Registration Key](http://www.vmix.com/)

[Visit https://register.vmix.com/ to register for the FREE Basic Edition](https://register.vmix.com/)

Register for a fully functional 60 Day Trial

**Email Address**

- Select the initial resolution and frame rate then click OK.

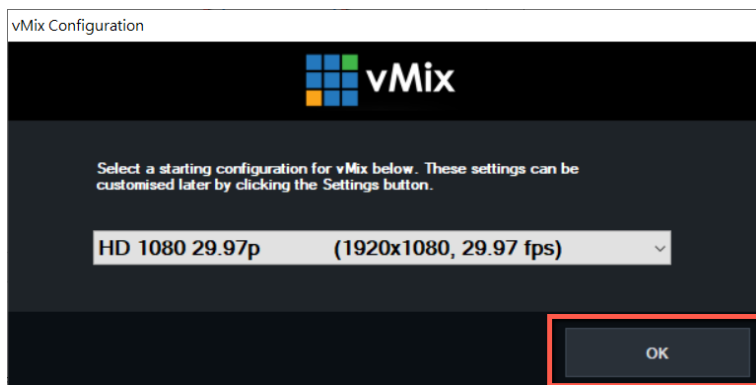

vMix Configuration

**vMix**

Select a starting configuration for vMix below. These settings can be customised later by clicking the Settings button.

**HD 1080 29.97p** (1920x1080, 29.97 fps) ▾

- The vMix software interface is shown below.



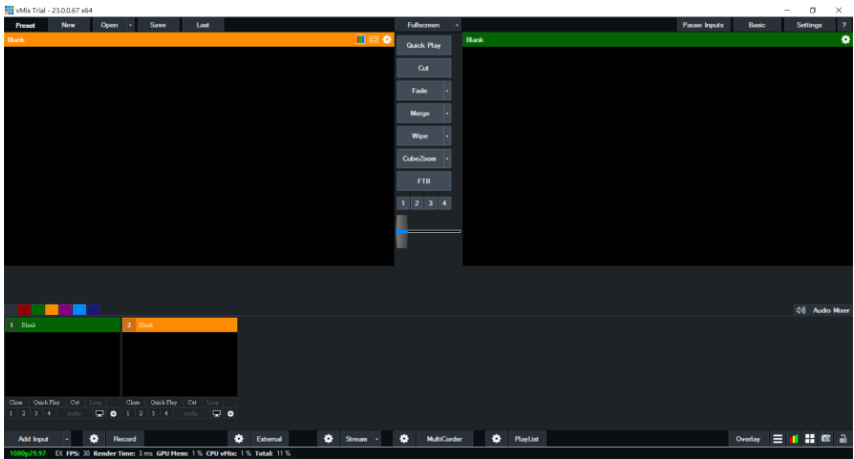

### ***SRT Stream Setup using PTC-140T and vMix***

The PTC-140T/vMIX connection is bidirectional. Depending on the caller-listener setup, either end can be the camera video source.

#### **PTC-140T set to the Listener Mode**

Open the web UI of the PTC-140T then click Network Configure → SRT. Use the default SRT port (9000) then set the password of your SRT stream as well as the crypto key length. In this example, the crypto key length is set to 32 bytes and the password is “8888888888”. click the **Save** button to save the SRT listener settings.

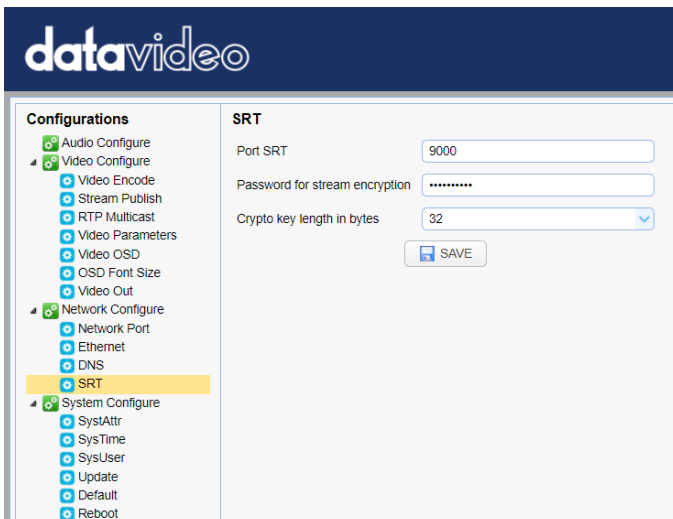

Reboot (System Configure → Reboot) the camera to apply the new settings.

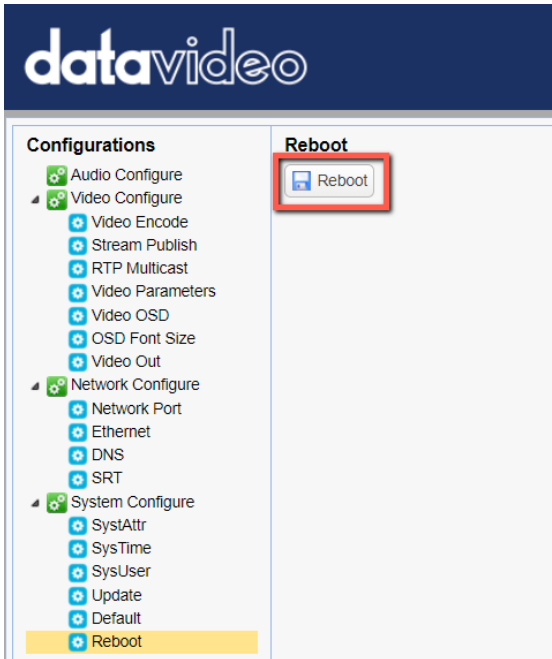

On the PC or laptop where the vMIX is installed, click Start Menu → vMix(x64) and you should see the interface below after the vMIX is opened.

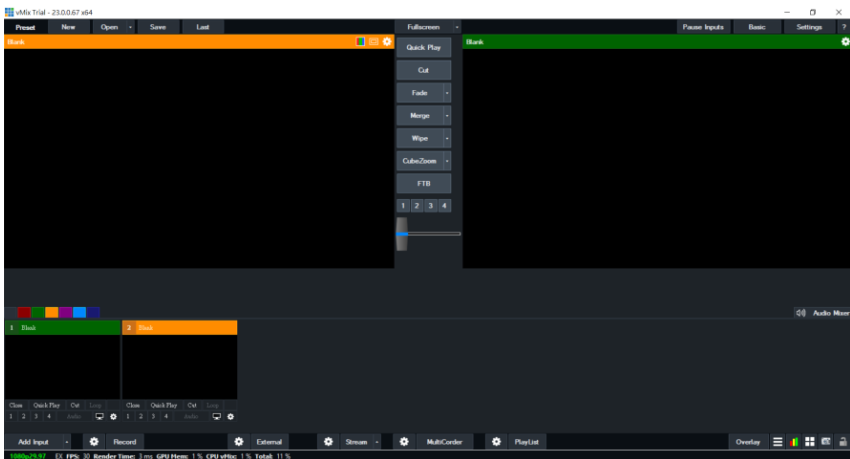

Click “Add Input” then “More”.

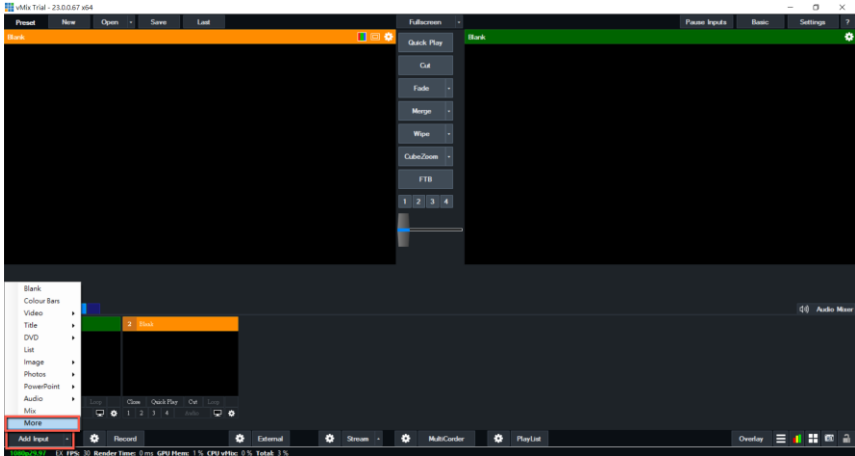

On the Input Select window, click “Stream/SRT” then select “SRT Caller” from the “Stream Type” drop-down menu. After that, enter the following into the respective fields.

- Hostname: 192.168.2.5 (The IP address of your connected device. In this case, it is the PTC-140)
- Port: 9000
- Passphrase: 8888888888 (The password set previously on the PTC-140T’s Web UI)
- Key length: 32 (The same length as the key length set previously on the PTC-140T’s Web UI)

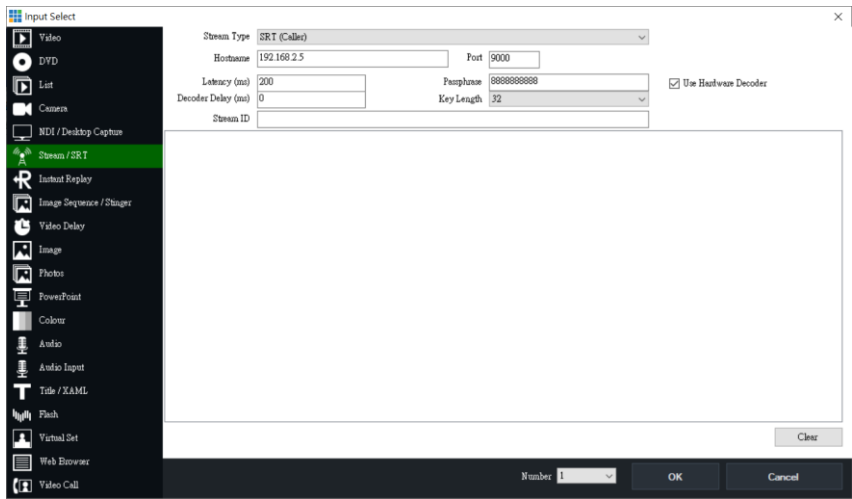

Click the “OK” button.

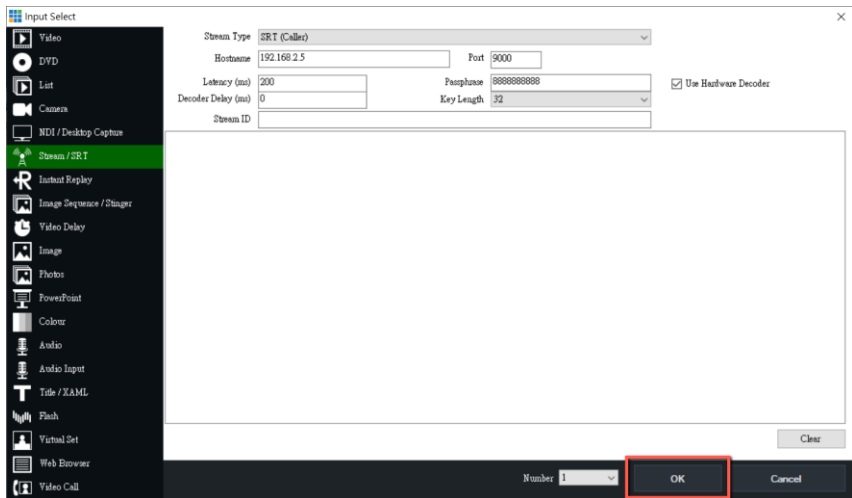

The PTC-140T camera video is now successfully streamed to the vMix via SRT.

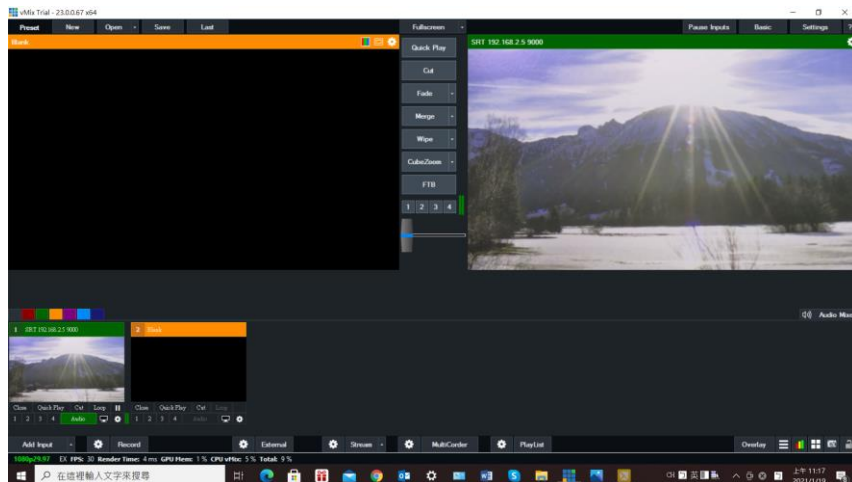

### PTC-140T set to the Caller Mode

Open the web UI of the PTC-140T then click **Stream Publish**.

Set the protocol to SRT then enter the following into the respective fields.

- Host Address: 192.168.2.50 (IP address of the PC/laptop on which the vMIX is installed)
- Host Port: 5000
- Crypto Key Length: 32
- Password for Stream Encryption: 8888888888 (Please note that the password is arbitrary)

Click the **Save** button to save the SRT caller settings.

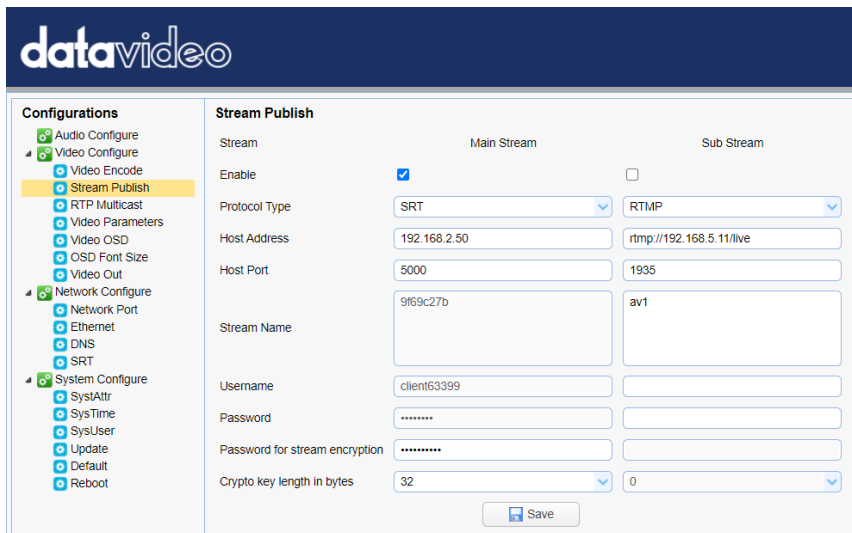

Reboot (System Configure → Reboot) the camera to apply the new settings.

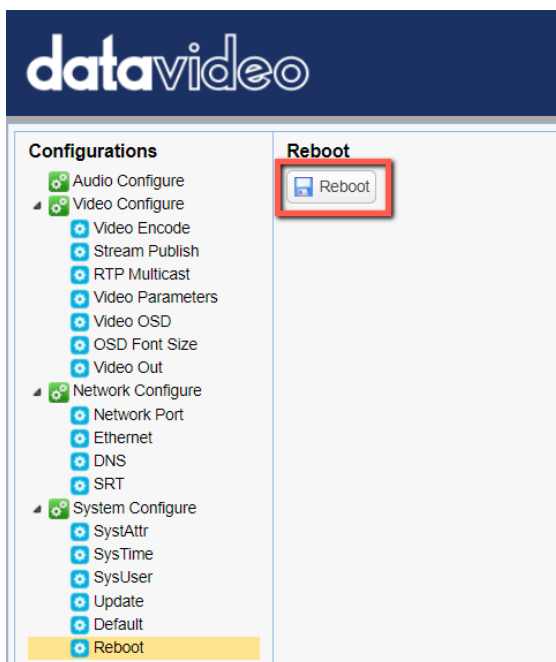

On the PC or laptop where the vMIX is installed, click Start Menu → vMix(x64) and you should see the interface below after the vMIX is opened.

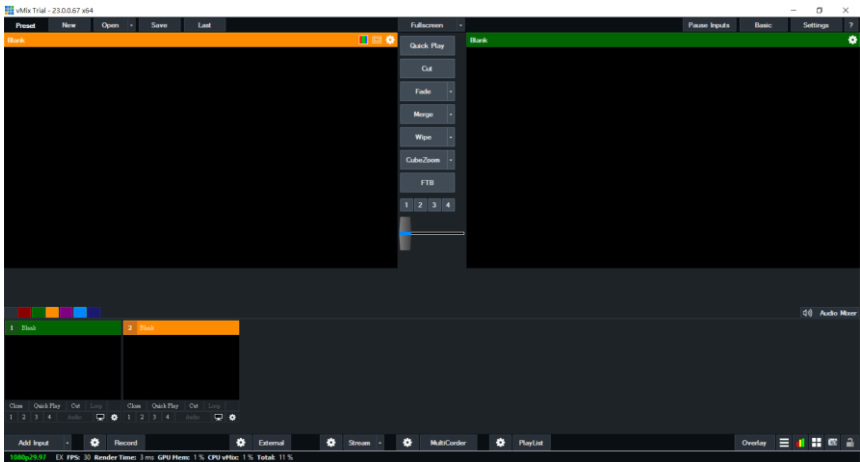

Click “Add Input” then “More”.

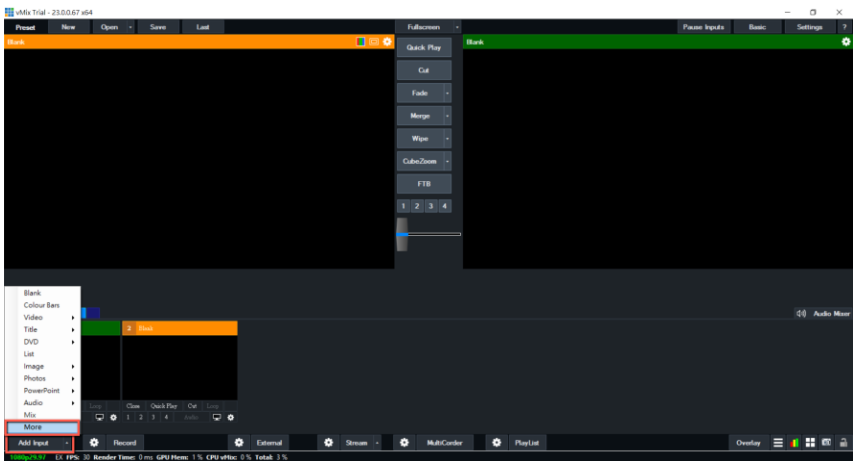

On the Input Select window, click “Stream/SRT” then select “SRT Listener” from the “Stream Type” drop-down menu. After that, enter the following into the respective fields.

- Port: 5000
- Passphrase: 8888888888 (Password for Stream Encryption)
- Key length: 32 (The same length as the key length set previously on the PTC-140’s Web UI)

Click the “OK” button.

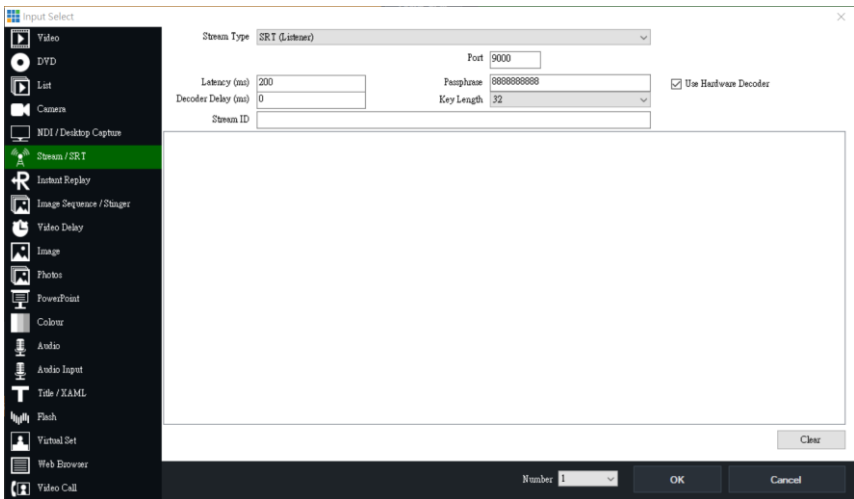

The PTC-140T camera video is now successfully streamed to the vMix via SRT.

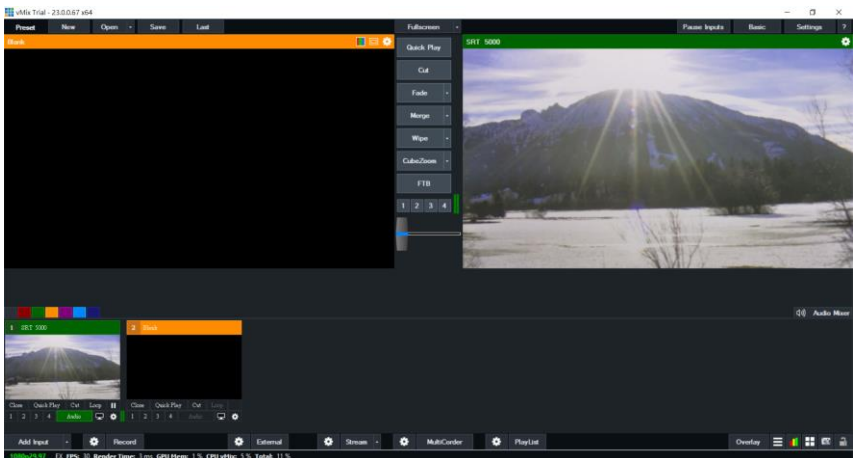

### ***RTP Multicast***

The RTP Multicast allows you to view camera video on certain video players such as VLC media player from a remote location.



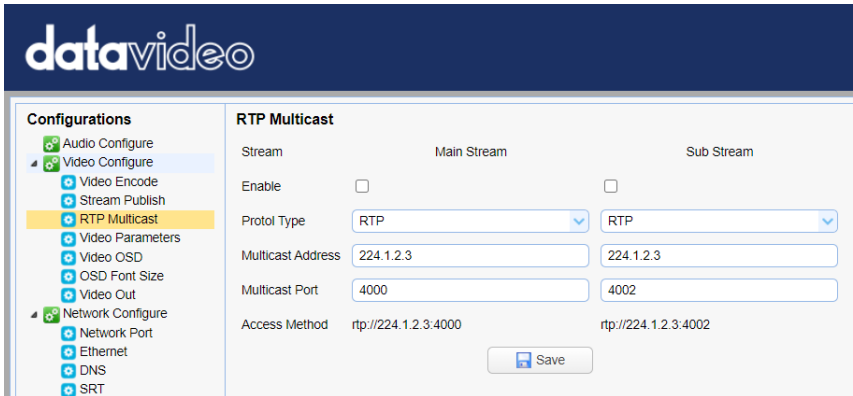

Follow the steps outlined below to view the camera video on VLC media player.

1. Download VLC media player from the link <https://www.videolan.org>.
2. Open VLC, click “Media” → “Open Network Stream” then enter rtp://224.1.2.3:4000 to view the main stream and rtp://224.1.2.3:4002 to view the sub stream.

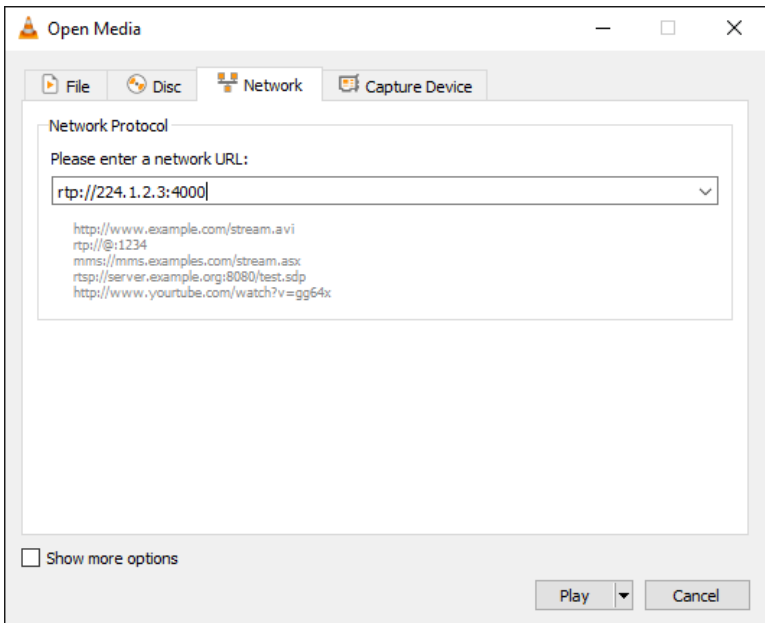

3. Click the “**Play**” button to start viewing the video stream.

You can also choose to stream over TS protocol. Follow the steps outlined below to view the camera video on VLC media player over TS protocol.

1. On **RTP Multicast** page of the PTC-140T's web interface, select "TS" from the Protocol Type drop-down menu.

Stream	Main Stream	Sub Stream
Enable	<input type="checkbox"/>	<input type="checkbox"/>
Protol Type	TS	RTP
Multicast Address	224.1.2.3	224.1.2.3
Multicast Port	4000	4002
Access Method	udp://@224.1.2.3:4000	rtp://224.1.2.3:4002

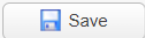

2. Open VLC media player, click "Media" → "Open Network Stream" then enter `udp://@224.1.2.3:4000` to view the main stream and `udp://@224.1.2.3:4002` to view the sub stream.
3. Click the "Play" button to start viewing the video stream.

### ***Video Parameters***

This sets the camera focus, exposure, color balance, image settings, noise reduction and picture styles.

#### **Focus**

In **Focus**, you are allowed to set **Focus Mode**, **Auto Focus Zone** and **Auto Focus Sensitivity**.

### Configurations

- Audio Configure
- Video Configure
  - Video Encode
  - Stream Publish
  - RTP Multicast
  - Video Parameters
  - Video OSD
  - OSD Font Size
  - Video Out
- Network Configure
  - Network Port
  - Ethernet
  - DNS
  - SRT
- System Configure
  - SysAttr
  - SysTime
  - SysUser
  - Update
  - Default
  - Reboot

### Video Param



Focus
Exposure
Color
Image
NR
Style
Refresh

Focus Mode

AF-Zone

AF-Sensitivity

\*Click the "Refresh" button to refresh parameter.

\*Effective after changed parameters

- Focus Mode: Available modes are **Auto**, **Manual** and **One Push**.
- AF-Zone: This sets auto focus zone by selecting **Top**, **Center**, **Bottom** or **All** from the drop-down menu.
- AF-Sensitivity: This sets auto focus sensitivity by selecting High, Middle and Low from the drop-down menu.

### Exposure

In **Exposure**, you are allowed to set Exposure Mode, Exposure Value (EV), Backlight Compensation (BLC), Anti-Flicker, Gain Limit and Dynamic Range Compression (DRC).

### Configurations

- Audio Configure
- Video Configure
  - Video Encode
  - Stream Publish
  - RTP Multicast
  - Video Parameters
  - Video OSD
  - OSD Font Size
  - Video Out
- Network Configure
  - Network Port
  - Ethernet
  - DNS
  - SRT
- System Configure
  - SystAttr
  - SysTime
  - SysUser
  - Update
  - Default
  - Reboot

### Video Param



Focus
**Exposure**
Color
Image
NR
Style
 Refresh

Mode:

EV:

BLC:

Flicker:

G.Limit:  3

DRC:

\*Click the "Refresh" button to refresh parameter.

\*Effective after changed parameters

- Mode: Available focus modes are **Auto**, **Manual**, **SAE (Shutter Automatic Exposure)**, **AAE (Aperture Automatic Exposure)** and **Bright**.

**Auto** – Fully automatic settings for shutter speed and aperture with ability to adjust gain, dynamic range, backlight and anti-flicker.

**Manual** – Full iris, shutter speed and range control

**Shutter Automatic Exposure** – The camera will measure light and automatically set the aperture based on your desired shutter speed.

**Aperture Automatic Exposure** – The camera will measure light and automatically set the shutter speed based on your desired iris opening (aperture).

- EV: **EV** is exposure value. By turning it ON, an EV slider will appear for adjusting the exposure value.

- BLC: By turning the **backlight compensation**, the camera will compensate for backlight by enhancing automatic exposure control on the camera.
- Flicker: To avoid video flicker, you can set your camera flicker frequency to **50Hz** or **60Hz**.
- Gain Limit Slider: Select gain limit from 0 to 15.
- DRC: Sets the amount of Dynamic Range Compression where higher values lead to more compression (**1 – 8** or **off**).

## Color

In **Color**, you are allowed to set color balance such as white balance, red gain fine tuning, blue gain fine tuning, saturation, hue and automatic white balance sensitivity. The color balance of your image will change the colors rendered in your image.

The screenshot displays the DataVideo web interface. On the left is a 'Configurations' sidebar with a tree view where 'Video Parameters' is highlighted. The main area is titled 'Video Param' and features a live video feed of a snowy mountain landscape. Below the video is a control panel with tabs for 'Focus', 'Exposure', 'Color', 'Image', 'NR', and 'Style', along with a 'Refresh' button. The 'Color' tab is active, showing the following settings:

WB Mode	Auto	
RG Tuning	<input type="range"/>	0
BG Tuning	<input type="range"/>	0
Saturation	100%	
Hue	<input type="range"/>	7
AWB Sensitivity	High	

Below the control panel, there are two red text instructions:
   
\*Click the "Refresh" button to refresh parameter.
   
\*Effective after changed parameters

- WB Mode: Select white balance mode from the options listed below.
  - Auto
  - Manual
  - One Push
  - VAR (2400K – 7100K with a step size of 100)
- RG Tuning: This fine tunes the red gain from **-10 to 10** but effective only in **AUTO** mode.
- BG Tuning: This fine tunes the blue gain from **-10 to 10** but effective only in **AUTO** mode.
- Saturation: **60% to 200%**.  
**Note: The higher the saturation, the more vivid the colors will be.**
- Hue: Chroma adjustment from **0 to 14**.
- AWB Sensitivity: This is the white balance sensitivity; select **Low, Middle** or **High**.

## Image

Other image settings include brightness, contrast, sharpness, gamma, digital cinema, black and white, orientation and digital zoom.

## Configurations

- Audio Configure
- Video Configure
  - Video Encode
  - Stream Publish
  - RTP Multicast
  - Video Parameters
  - Video OSD
  - OSD Font Size
  - Video Out
- Network Configure
  - Network Port
  - Ethernet
  - DNS
  - SRT
- System Configure
  - SystAttr
  - SysTime
  - SysUser
  - Update
  - Default
  - Reboot

## Video Param



Focus	Exposure	Color	Image	NR	Style	Refresh
Bright	<input type="range" value="7"/>					
Contrast	<input type="range" value="8"/>					
Sharpness	<input type="range" value="5"/>					
Gamma	<input type="text" value="0.45"/>					
DCI	<input type="text" value="OFF"/>					
B&W Mode	<input type="button" value="Color"/>					
Flip-H	<input type="button" value="OFF"/>					
Flip-V	<input type="button" value="OFF"/>					
DZoom	<input type="button" value="OFF"/>					
Low-Light Mode	<input type="button" value="OFF"/>					

\*Click the "Refresh" button to refresh parameter.

\*Effective after changed parameters

- Bright: Brightness level adjustment from **0 to 14**.
- Contrast: Contrast adjustment from **0 to 14**.
- Sharpness: Sharpness adjustment from **0 to 15**.
- Gamma: Select a gamma value from the following
  - Default
  - 0.45
  - 0.50
  - 0.55
  - 0.63

- DCI: To enable DCI, simply select a value from **1 to 8**; selecting **OFF** will disable DCI.
- B&W Mode: This allows you to switch between color and black-and-white modes.
- Flip-H: Turning it ON flips the image along the y-axis.
- Flip-V: Turning in ON flips the image along the x-axis.
- DZoom: This enables/disables digital zoom.
- Low-Light Mode: This enables/disables Low-Light Mode.

## NR

Image noise is extremely distracting to viewers and enabling noise reduction will remove noise to achieve a broadcast quality image.

**Configurations**

- Audio Configure
- Video Configure
  - Video Encode
  - Stream Publish
  - RTP Multicast
  - Video Parameters**
  - Video OSD
  - OSD Font Size
  - Video Out
- Network Configure
  - Network Port
  - Ethernet
  - DNS
  - SRT
- System Configure
  - SystAttr
  - SysTime
  - SysUser
  - Update
  - Default
  - Reboot

**Video Param**

Focus Exposure Color Image **NR** Style Refresh

NR-2D 1

NR-3D 5

Dynamic Hot Pixel OFF

\*Click the "Refresh" button to refresh parameter.  
\*Effective after changed parameters

- NR-2D: 2D noise reduction is ideal for scenes with movement.
  - OFF



- 1 – 7
- Auto
- NR-3D: 3D noise reduction is ideal for static fields of view.
  - OFF
  - 1 – 7

**Note: By using both 2D and 3D noise reduction together, you can effectively enhance both moving and static imagery, which is ideal for most live broadcast environments.**

- Dynamic Hot Pixel: Hot pixels are bright colored spots in your images, often noticeable with slow shutter speeds or high ISO settings. By enabling the dynamic hot pixel feature, these spots will be automatically removed.
  - OFF
  - 1 – 5

## **Style**

In **Style**, you will be able to select the picture style of your preference. The available styles are:

- Default
- Normal
- Clarity
- Bright
- Soft

### Configurations

- Audio Configure
- Video Configure
  - Video Encode
  - Stream Publish
  - RTP Multicast
  - Video Parameters**
  - Video OSD
  - OSD Font Size
  - Video Out
- Network Configure
  - Network Port
  - Ethernet
  - DNS
  - SRT
- System Configure
  - SystAttr
  - SysTime
  - SysUser
  - Update
  - Default
  - Reboot

### Video Param



Focus Exposure Color Image NR **Style** Refresh

Style

*\*Click the "Refresh" button to refresh parameter.*  
*\*Effective after changed parameters*

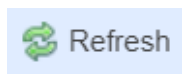

**Note: Each time after you modify the camera parameters, please click the Refresh button to apply the new settings.**

### **Video OSD**

In **Video OSD**, you will be allowed to show video time and title on the screen. You can further set the font color as well as their positions.

The screenshot shows the DataVideo configuration interface. On the left is a 'Configurations' sidebar with a tree view. The 'Video OSD' option is highlighted in yellow. The main area is titled 'Video OSD' and contains a video preview window showing a mountain landscape. Below the preview are several controls: 'Show Time' and 'Show Title' checkboxes (both unchecked), 'Time Font Color' and 'Title Font Color' dropdown menus (both set to 'White'), and 'OSD Offset' radio buttons (with 'Title' selected). There are also four directional arrow buttons and a 'Save' button at the bottom.

## Enable Video Time and Title on Screen

Show Time

Show Title

Simply check the checkbox then click the **Save** button to display video time and title on the screen.

## Set Font Color of Time and Title

You can also select a display color for your time and title. Available color options include:

- White
- Black
- Yellow
- Red
- Blue

## Adjust Time and Title Positions



On the OSD Offset tile, you will be allowed to adjust positions of the Time and Title displayed on the screen. First select Time or Title then click the arrow buttons to move it to the desired position.



**Note:** After you've configured the video time and title, click the Save button to apply the new settings.

## OSD Font Size

In **OSD Font Size**, you can set the font size for the Master and Slave streams by entering a number into the respective textboxes shown in the diagram below. In addition, you can also select to allow the system to scale the font size automatically according to the resolution set.

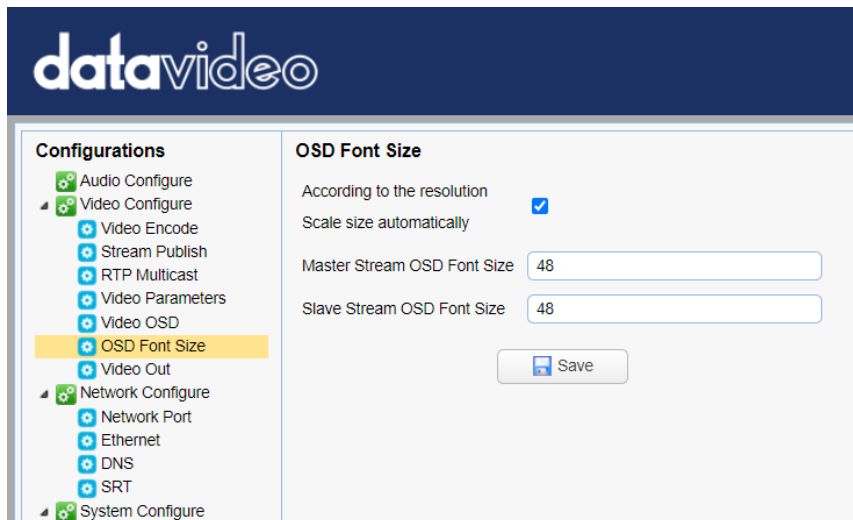

## Video OUT

The **Video Out** allows users to select the desired video output resolution from the drop-down menu. Supported output resolutions include:

- 1080P60
- 1080P50

- 1080P30
- 1080P25
- 1080I60
- 1080I50
- 720P60
- 720P50
- 1080P59.94
- 1080I59.94
- 720P59.94
- 1080P29.97

**Note:** Click the Save button after you've selected a resolution.

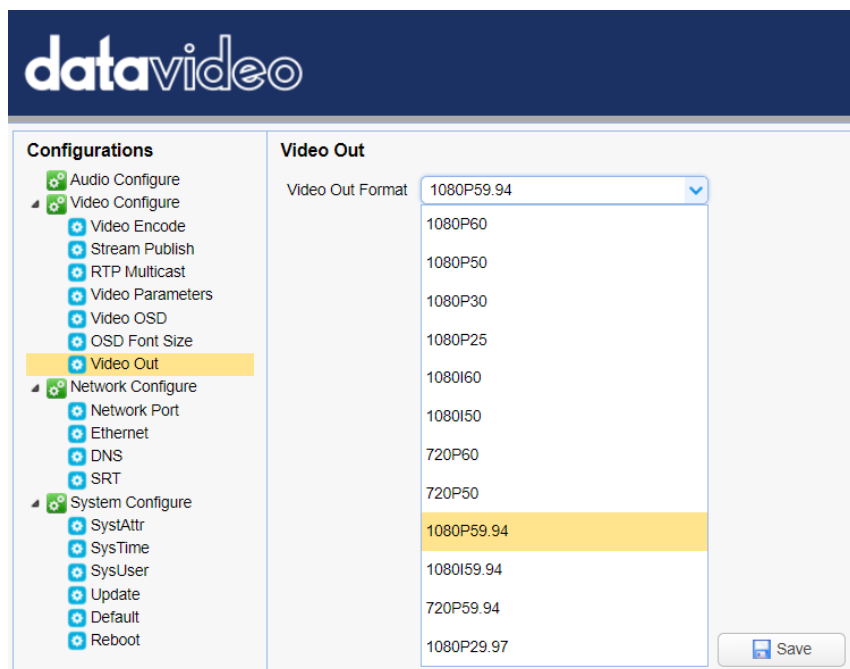

## Network Configure

Network Configure allows you to configure the network functions of your camera.

## Network Port

In **Network Port**, you should be able to find a list of default port numbers for different data communication protocols. Please note that these port numbers may vary according to your network environment.

**Note:** Click the **Save** button after you've edited the port numbers.

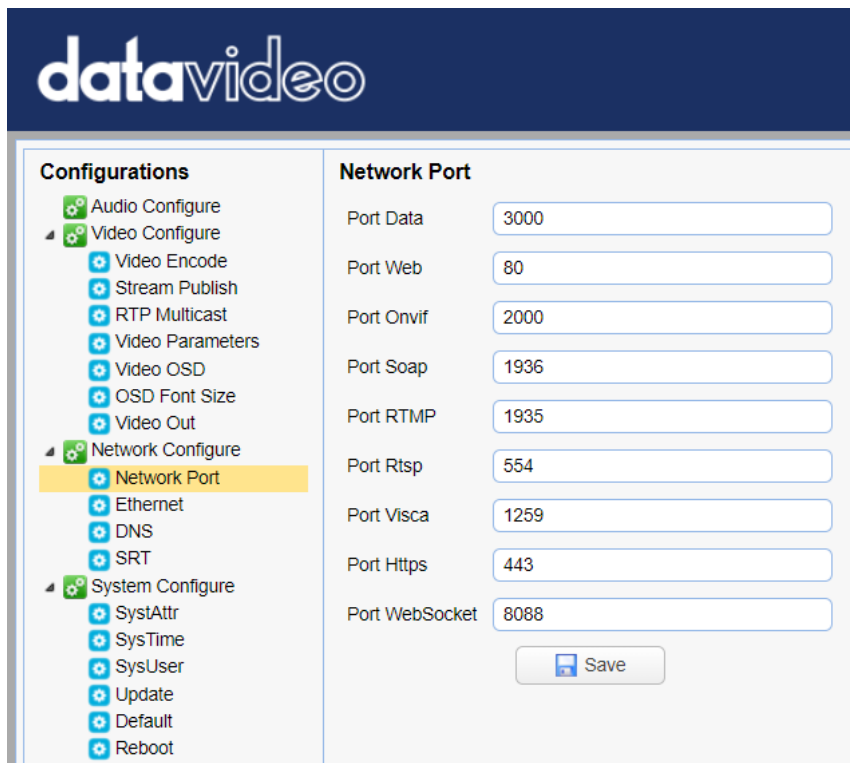

The screenshot shows the DataVideo configuration interface. The top header is dark blue with the 'datavideo' logo in white. Below the header, there are two main sections: 'Configurations' on the left and 'Network Port' on the right. The 'Configurations' section is a tree view with a green gear icon next to each category. The categories are: Audio Configure, Video Configure (expanded), Network Configure (expanded), and System Configure (expanded). Under 'Video Configure', there are: Video Encode, Stream Publish, RTP Multicast, Video Parameters, Video OSD, OSD Font Size, and Video Out. Under 'Network Configure', there are: Network Port (highlighted in yellow), Ethernet, DNS, and SRT. Under 'System Configure', there are: SystAttr, SysTime, SysUser, Update, Default, and Reboot. The 'Network Port' section on the right lists various ports with input fields: Port Data (3000), Port Web (80), Port Onvif (2000), Port Soap (1936), Port RTMP (1935), Port Rtsp (554), Port Visca (1259), Port Https (443), and Port WebSocket (8088). At the bottom of this section is a 'Save' button with a blue floppy disk icon.

## Ethernet

In **Ethernet**, you are allowed to modify your network settings according to your network environment. For more details on **DHCP** and **Static IP Mode**, see [\*\*Network Connection\*\*](#).

**Note:** Click the **Save** button after you've edited the network settings.

## Configurations

- Audio Configure
- Video Configure
  - Video Encode
  - Stream Publish
  - RTP Multicast
  - Video Parameters
  - Video OSD
  - OSD Font Size
  - Video Out
- Network Configure
  - Network Port
  - Ethernet**
  - DNS
  - SRT
- System Configure
  - SystAttr
  - SysTime
  - SysUser
  - Update
  - Default
  - Reboot

## Ethernet

DHCP

IP Address

Subnet Mask

Default Gateway

MAC Address

## DNS

In **DNS**, Enter the DNS information which is 8.8.8.8 by default.

## Configurations

- Audio Configure
- Video Configure
  - Video Encode
  - Stream Publish
  - RTP Multicast
  - Video Parameters
  - Video OSD
  - OSD Font Size
  - Video Out
- Network Configure
  - Network Port
  - Ethernet
  - DNS**
  - SRT
- System Configure
  - SystAttr

## DNS

Preferred DNS Server

Alternative DNS Server

## **SRT**

In SRT, you can set the port number for the SRT stream. The default port number is 9000. The password and the key length allow you to encrypt the SRT stream.

**Note:** Click the **Save** button after you've edited the SRT settings.

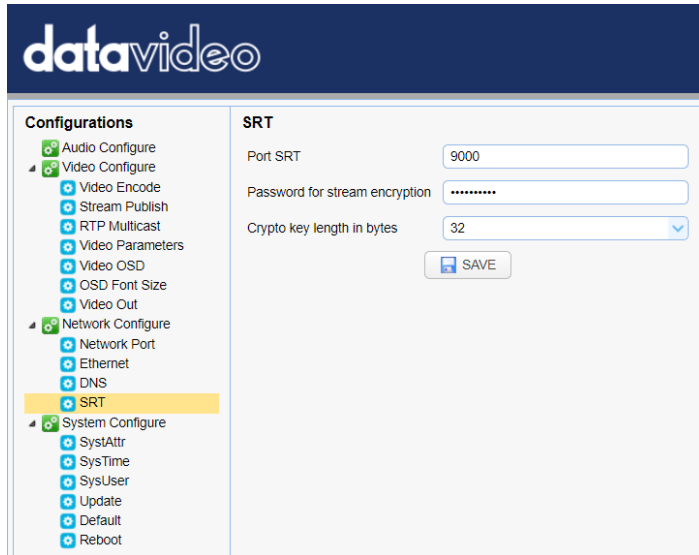

The screenshot shows the DataVideo web interface. On the left is a 'Configurations' sidebar with a tree view. The 'SRT' option is highlighted in yellow. The main area is titled 'SRT' and contains three input fields: 'Port SRT' with the value '9000', 'Password for stream encryption' with a masked password '\*\*\*\*\*', and 'Crypto key length in bytes' with a dropdown menu set to '32'. A 'SAVE' button is located below these fields.

## **System Configure**

System Configure allows you to configure your camera system.

### **System Attribute**

In System Attribute, you are allowed to edit your camera name and select the Web UI language. Available languages are **Traditional Chinese**, **Simplified Chinese** and **English**.



The screenshot displays the DataVideo configuration interface. On the left, a 'Configurations' sidebar lists various settings categories: Audio Configure, Video Configure (expanded), Network Configure (expanded), and System Configure (expanded). Under 'System Configure', 'SystAttr' is highlighted in yellow. The main area, titled 'System Attribute', contains three input fields: 'Device Name' with the value 'PTC-140', 'Device ID' with the value '1', and 'Language' with a dropdown menu set to 'English'. A 'Save' button is located below these fields.

## **System Time**

In **System Time**, you are allowed to set the **Date Format, Time Zone, Hour Type** and **NTP**.

NTP stands for Network Time Protocol and it is an Internet protocol used to synchronize the clocks of devices over a network to some time reference. Once NTP is enabled, you will be allowed to select the update frequency and assign the time server.

If NTP is not enabled, you may choose to synchronize the device time with the computer time.

**datavideo**

**Configurations**

- Audio Configure
- Video Configure
  - Video Encode
  - Stream Publish
  - RTP Multicast
  - Video Parameters
  - Video OSD
  - OSD Font Size
  - Video Out
- Network Configure
  - Network Port
  - Ethernet
  - DNS
  - SRT
- System Configure
  - SystAttr
  - SysTime**
  - SysUser
  - Update
  - Default
  - Reboot

**System Time**

Date Format: YYYY-MM-DD

Date Sprtr: /

Zone: (GMT+08:00)Beijing, Hongkong, Sin

Hour Type: 24 Hours

NTP Enable:

Update Interval: 1 day

Host Url: time.nist.gov

Host Port: 123

**Time Settings**

Time Settings: Synchronize with computer time

Computer Time: 2021-01-22 10:21:23

## System User

In **System User**, you are allowed to edit the login credentials for Admin, User 1 and User 2.

**Note:** Click the **Save** button to save the new login credentials.

**datavideo**

**Configurations**

- Audio Configure
- Video Configure
  - Video Encode
  - Stream Publish
  - RTP Multicast
  - Video Parameters
  - Video OSD
  - OSD Font Size
  - Video Out
- Network Configure
  - Network Port
  - Ethernet
  - DNS
  - SRT
- System Configure
  - SystAttr
  - SysTime
  - SysUser**

**User Set**

Authority: admin

User Name: admin

Password: .....

Confirm Password: [Red border]

## Update

This is where you will be able to view current firmware information. See **Firmware Update** for detailed firmware upgrade instructions.

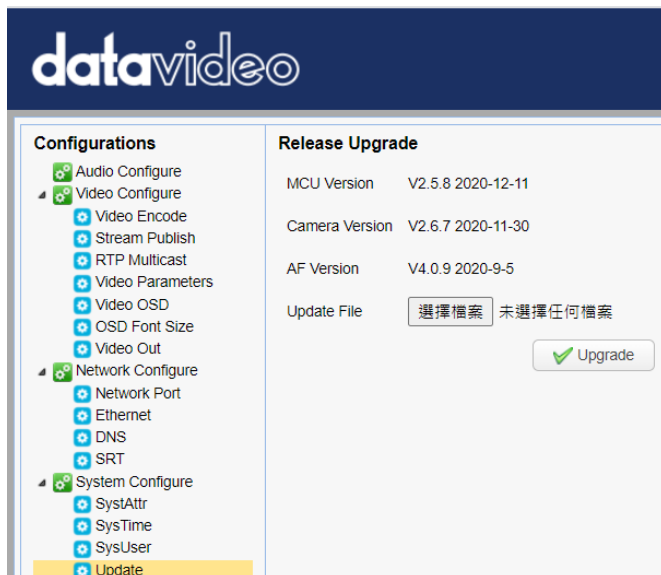

The screenshot shows the DataVideo web interface. The top navigation bar is dark blue with the 'datavideo' logo in white. The main content area is divided into two columns. The left column, titled 'Configurations', contains a tree view of settings: Audio Configure, Video Configure (expanded), Video Encode, Stream Publish, RTP Multicast, Video Parameters, Video OSD, OSD Font Size, Video Out, Network Configure (expanded), Network Port, Ethernet, DNS, SRT, System Configure (expanded), SystAttr, SysTime, SysUser, and Update (highlighted in yellow). The right column, titled 'Release Upgrade', displays firmware information: MCU Version V2.5.8 2020-12-11, Camera Version V2.6.7 2020-11-30, and AF Version V4.0.9 2020-9-5. Below this is an 'Update File' section with a button labeled '選擇檔案' (Select File) and the text '未選擇任何檔案' (No file selected). A green checkmark icon and an 'Upgrade' button are also present.

## Default

In **Default**, click “Restore factory defaults” to reset the device to factory defaults.

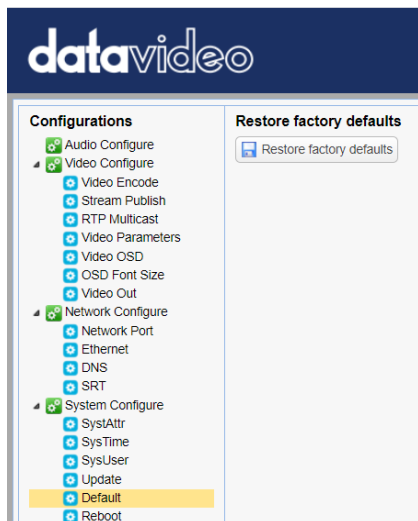

The screenshot shows the DataVideo web interface. The top navigation bar is dark blue with the 'datavideo' logo in white. The main content area is divided into two columns. The left column, titled 'Configurations', contains a tree view of settings: Audio Configure, Video Configure (expanded), Video Encode, Stream Publish, RTP Multicast, Video Parameters, Video OSD, OSD Font Size, Video Out, Network Configure (expanded), Network Port, Ethernet, DNS, SRT, System Configure (expanded), SystAttr, SysTime, SysUser, Update, Default (highlighted in yellow), and Reboot. The right column, titled 'Restore factory defaults', contains a single button labeled 'Restore factory defaults'.

## Reboot

Click “**Reboot**” to reboot the device.

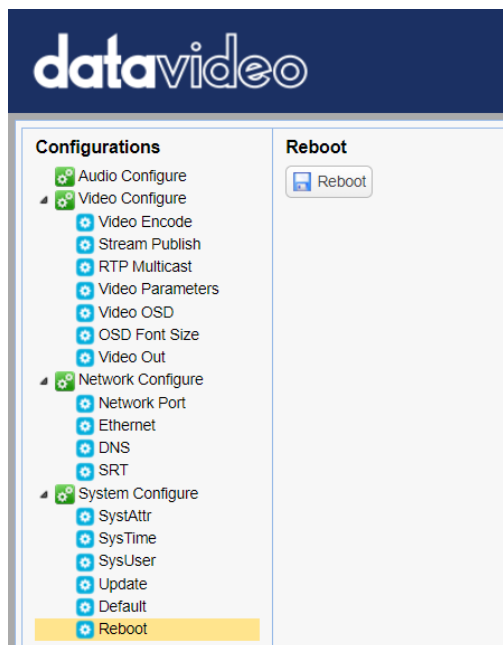

## 8. Remote Control Port Pinout

You can connect your PC or any keyboard controllers to the 8pin mini-DIN RS-232 port to control the PTC-140T from a remote location. The 8pin mini-DIN RS-232 port can be found on the camera's rear panel. Use a mini-Din 8 pin to DB9 pin adapter cable to connect the external controller to the PTC-140T. You can make a custom cable using the pinout information provided in this chapter.

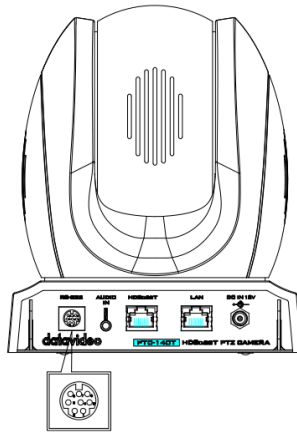

PTC-140T	Controller's DB-9 RS-232 Port
1.DTR	1.DCD
2.DSR	2.RXD
3.TXD	3.TXD
4.GND	4.DTR
5.RXD	5.GND
6.GND	6.DSR
7.IR OUT	7.RTS
8.NC	8.CTS
	9.RI

## RS-232 Mini-Din Connector Pinout

NO.	Pin	Descriptions
1	DTR	Data Terminal Ready
2	DSR	Data Set Ready
3	TXD	Transmit Data
4	GND	System Ground
5	RXD	Receive Data
6	GND	System Ground
7	IR OUT	IR Commander Signal
8	NC	No Connection

## RS-232 DB9 Connector Pinout

NO.	Pin	Descriptions
1	DCD	Data Carrier Detect
2	RXD	Receive Data
3	TXD	Transmit Data
4	DTR	Data Terminal Ready
5	GND	System Ground
6	DSR	Data Set Ready
7	RTS	Request to Send
8	CTS	Clear to Send
9	RI	Ring Indicator

## 9. Firmware Update

Datavideo usually releases new firmware containing new features or reported bug fixes from time to time. Customers can either download the firmware as they wish or contact their local dealer or reseller for assistance.

This section outlines the firmware upgrade process which should take ***approximately few minutes to complete.***

**The existing settings should persist through the *firmware upgrade process, which should not be interrupted once started* as this could result in a non-responsive unit.**

### Requirements

- PTC-140T Unit
- PC/Laptop
- Latest firmware files  
Download from <https://www.datavideo.com/product/PTC-140T>
- Ethernet Cable
- Router if connected over a network

### Procedure

1. Open the web user interface of the PTC-140T.
2. Click “System Configure” → “Update”

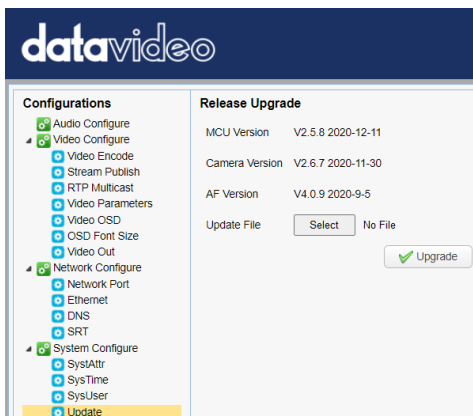

3. Click the “Select File” button to browse your disk for the latest firmware file.
4. Click the “Upgrade” button to start upgrading the firmware.

## 10. Frequently-Asked Questions

This section describes problems that you may encounter while using the PTC-140T. If you have questions, please refer to related sections and follow all the suggested solutions. If problem still exists, please contact your distributor or the service center.

No.	Problems	Solutions
1.	What are important points of product maintenance?	<ol style="list-style-type: none"> <li>1. If the camera will not be used for a long time, please unplug the 12V DC power plug, and remove AC power adapter from AC outlet.</li> <li>2. Use soft cloth or tissue to clean the camera.</li> <li>3. After washing the camera lens, dry it with a soft dry cloth. Use a neutral detergent rather than acidic or corrosive detergents to clean the lens.</li> </ol>
2.	There is no output video.	<ol style="list-style-type: none"> <li>1. Check that your power is properly connected. This is indicated by the power LED.</li> <li>2. Make sure the camera is switched ON.</li> <li>3. Check your video cable connection.</li> </ol>
3.	I have seen image jitter while zooming in or out.	<ol style="list-style-type: none"> <li>1. Make sure the camera is properly mounted.</li> <li>2. Make sure that machines that could cause vibration are not in proximity of the camera.</li> </ol>
4.	The remote control is not working.	<ol style="list-style-type: none"> <li>1. Try setting the camera to CAM1 and try again.</li> <li>2. Make sure the remote control's battery is fully charged.</li> <li>3. Check your device working mode.</li> <li>4. Make sure the OSD menu is turned off. The remote control cannot be used if the OSD menu is enabled.</li> </ol>
5.	The serial port is not working properly.	<ol style="list-style-type: none"> <li>1. Make sure you are using the standard connection cable provided by Datavideo.</li> <li>2. Make sure your baud rate and</li> </ol>



		<p>device addresses are correct.</p> <ol style="list-style-type: none"> <li>3. Check your cable connection.</li> <li>4. Check your device working mode.</li> </ol>
<b>6.</b>	I cannot log in to the web user interface.	<ol style="list-style-type: none"> <li>1. Check your Ethernet connection.</li> <li>2. Check your network settings such as IP address.</li> </ol>
<b>7.</b>	The camera image cannot be viewed in the preview window.	<p>Make sure you are using Google Chrome or Microsoft Edge to view the camera image in the preview window. The preview window cannot open in Microsoft Internet Explorer.</p> <p>The preview window may stop responding if the browser is left idle for a period of time. To resume playing, try refreshing the page or relogin the web UI.</p>

## 11. Dimensions

Unit: mm

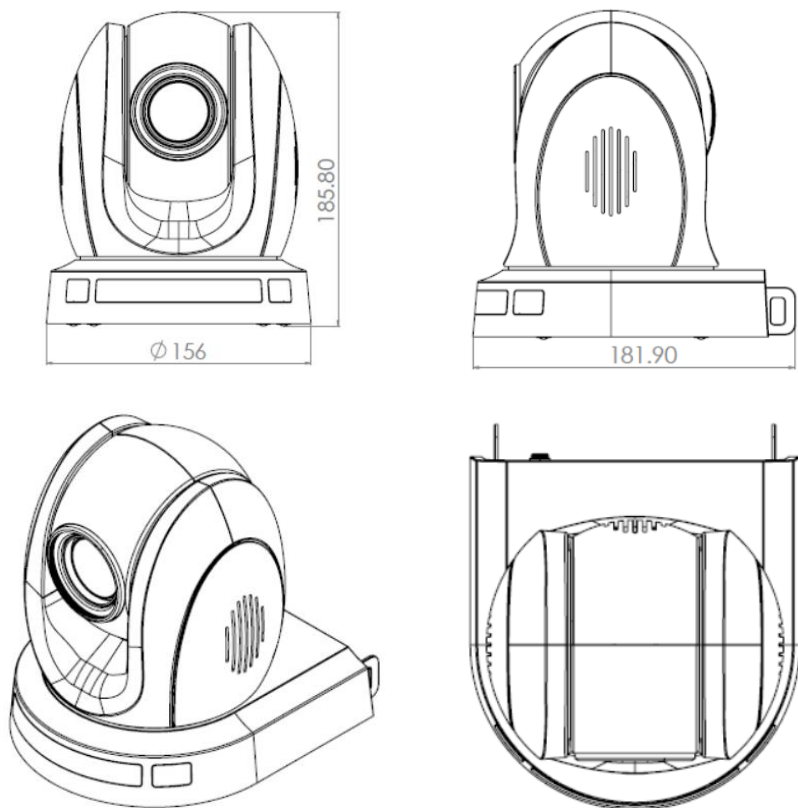

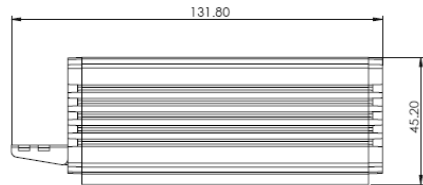
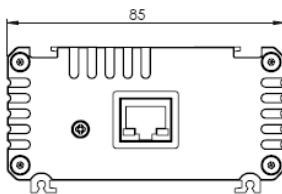
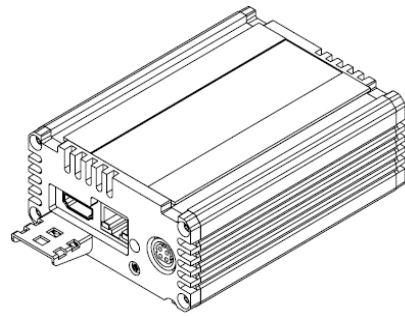
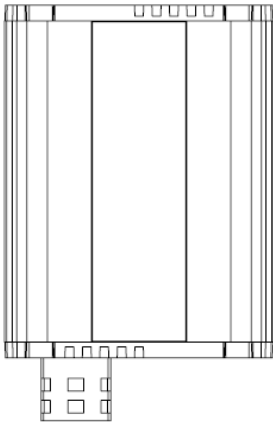
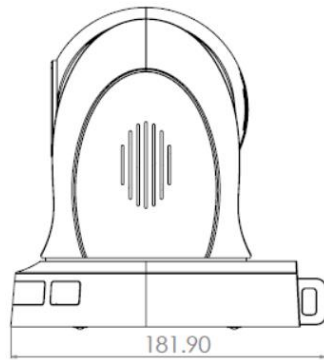
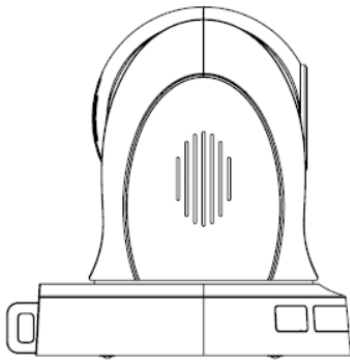

## 12. Specifications

Camera Parameters	
<b>Video Format</b>	1080p 60/59.94/50/30/29.97/25 1080i 60/59.94/50 720p 60/59.94/50
<b>Image Sensor</b>	1/2.8 inch high quality HD CMOS sensor
<b>Effective Pixels (approx.)</b>	2.07 Mega pixels
<b>S/N Ratio</b>	>55dB
<b>Min. Illumination</b>	0.5Lux (F1.8, AGC ON)
<b>Electronic Shutter</b>	Auto / Manual
<b>Zoom Ratio</b>	20x Optical Zoom, 10x Digital Zoom
<b>Gamma Control</b>	Off / Normal
<b>Iris Control</b>	Auto / Manual
<b>Digital Noise Reductions</b>	Yes
<b>On-Screen Display (OSD)</b>	English, Simplified Chinese
<b>White Balance</b>	Auto, Manual, One Push, 3000K, 4000K, 5000K, 6500K
<b>AGC / Gain Control</b>	Auto / Manual
<b>Mirror / Flip Image</b>	Yes
<b>Focus Mode</b>	Auto / Manual
<b>Panning / Tilting Range</b>	Pan: 340° Tilt: +90° to -30°
<b>Panning / Tilting Speed</b>	Pan: 0.1~60°/sec Tilt: 0.1~30°/sec
<b>Preset</b>	255 Positions
<b>Focal Length</b>	f=5.2 (wide) to 98 (tele) mm F1.6 to F3.5
<b>Field of View (Horizontal, Wide)</b>	Approx. 54.7° (WIDE END) / 3.3° (TELE END)
<b>Image Compensation</b>	Backlight Compensation

<b>Input /Output Interfaces</b>	
<b>Video Output</b>	HDBaseT (PoE) x1 RJ-45 x1
<b>Audio Input</b>	3.5mm Line in
<b>Tally LED</b>	Dual colors (Red, Green)
<b>Lens Filter</b>	M52.0 x 0.75 Thread with UV Protection
<b>Control Protocol</b>	VISCA/Pelco-D/Pelco-P; Baud Rate:115200/38400/9600/4800/2400bps DVIP
<b>Remote Control Interface and Transmit Distance</b>	RS-232 Lan (RJ-45) HDBaseT(RJ-45)/Serial control on Receiver Box: Transmit up to 100m
<b>Video Compression Format</b>	H.264, H.265, Dual stream output
<b>Audio Compression Format</b>	AAC/MP3/G.711A Audio compression
<b>HD IP Interface</b>	100M IP port(100BASE-TX); Support DVIP
<b>Streaming Protocols</b>	TCP/IP, HTTP, RTSP, RTMP(S), DHCP, Multicast, etc
<b>Others</b>	
<b>F/W Update</b>	Ethernet
<b>IR Control</b>	Yes
<b>Camera Control Unit</b>	HS-1500T/HS-1600T/HS-1600T MK II/RMC-180/RMC-300C
<b>Tripod Mount</b>	1/4-20 UNC
<b>Optional Accessories</b>	WM-1/ WM-10
<b>Color</b>	Dark Blue/White
<b>Dimension (LxWxH)</b>	156 x 184 x 186 mm
<b>Weight</b>	1.6 kg
<b>Operating Temp.</b>	0~40 °C
<b>Power</b>	DC 12V 12W

## Cable Selection

Video Resolutions (HDBaseT Connection)			
Cable	Range	Video Resolution	
CAT5e/6	100 meters	Up to 1080p, 60Hz, 36 bpp. Data rates lower than 5.3 Gbps or below 255 MHz TMDS clock.	
	70 meters	Ultra HD video formats: HDMI Deep color: 1080p, 60, 48 bpp.	
CAT6a/CAT7	100 meters(*)	4K x 2K Data rates higher than 5.3 Gbps or above 255 MHz TMDS clock.	
* Recommended Cables for Ultra-HD video at 100 Meter range			
Type	P/N	Manufacturer	Web
CAT7 S/FTP	FR-LSZH	Teldor	<a href="http://www.teldor.com/">http://www.teldor.com/</a>
CAT6A H-STP	HFFR	Teldor	<a href="http://www.teldor.com/">http://www.teldor.com/</a>
CAT.7	2170475	Earthline	<a href="http://products.lappgroup.com/online-catalogue/datacommunication-systems-for-ethernet-technology/">http://products.lappgroup.com/online-catalogue/datacommunication-systems-for-ethernet-technology/</a>

# Notes

---

## Service & Support

It is our goal to make your products ownership a satisfying experience. Our supporting staff is available to assist you in setting up and operating your system. Please refer to our web site [www.datavideo.com](http://www.datavideo.com) for answers to common questions, support requests or contact your local office below.

Please visit our website for latest manual update.

<https://www.datavideo.com/tw/product/PTC-140T>

**datavideo**  
[www.datavideo.com](http://www.datavideo.com)



@DatavideoUSA @DatavideoIndia2016  
@DatavideoEMEA @Datavideojapan  
@DatavideoTaiwan @DatavideoLatam  
@DatavideoAsia @DatavideoBrasil



@Datavideo  
@Datavideo\_EMEA  
@Datavideo\_Taiwan



@DatavideoUSA  
@DVTWDVCN



@DatavideoUSA  
@DatavideoEurope

All the trademarks are the properties of their respective owners.

Datavideo Technologies Co., Ltd. All rights reserved 2020

Sept...04.2023 Ver:E10