



TEST REPORT

ETSI EN 300 328 V2.2.2 (2019-07)

Report Reference No...... **HTT202302300E-2**

Compiled by
(position+printed name+signature)..... **Ervin Xu**

Supervised by
(position+printed name+signature)..... **Bruce Zhu**

Approved by
(position+printed name+signature)..... **Kevin Yang**

Date of issue..... **Feb.24,2023**

Testing Laboratory Name..... **Shenzhen HTT Technology Co., Ltd.**
Address..... **1F, B Building, Huafeng International Robotics Industrial Park, Gushu, Xixiang Street, Bao'an District, Shenzhen**

Applicant's name..... **SHENZHEN COMISO DIGITAL TECHNOLOGY LIMITED**
Address..... **12/F,XinLong Technology Park,SongGang Town, BaoAn District,ShenZhen City,China**

Test specification.....
Standard..... **ETSI EN 300 328 V2.2.2 (2019-07)**

Shenzhen HTT Technology Co., Ltd. All rights reserved.
This publication may be reproduced in whole or in part for non-commercial purposes as long as the Shenzhen HTT Technology Co., Ltd. is acknowledged as copyright owner and source of the material. Shenzhen HTT Technology Co., Ltd. takes no responsibility for and will not assume liability for damages resulting from the reader's interpretation of the reproduced material due to its placement and context.

Test item description..... Bluetooth wireless speaker
Trade Mark..... COMISO
SHENZHEN COMISO DIGITAL TECHNOLOGY LIMITED
Manufacturer..... 12/F,XinLong Technology Park,SongGang Town, BaoAn District,ShenZhen City,China
Model/Type reference..... X26L
List Model..... Signature Speaker
Ratings..... DC 3.7V/6000mAh From Battery and DC 5V/2A From External Circuit
Result..... **PASS**



TEST REPORT

Test Report No. :	HTT202302300E-2	Feb.24,2023
		Date of issue

Equipment under Test : Bluetooth wireless speaker

Model /Type : X26L

Listed Models : Signature Speaker

Applicant : **SHENZHEN COMISO DIGITAL TECHNOLOGY LIMITED**

Address : 12/F,XinLong Technology Park,SongGang Town,
BaoAn District,ShenZhen City,China

Manufacturer : **SHENZHEN COMISO DIGITAL TECHNOLOGY LIMITED**

Address : 12/F,XinLong Technology Park,SongGang Town,
BaoAn District,ShenZhen City,China

Test Result:	PASS
---------------------	-------------

The test report merely corresponds to the test sample.
It is not permitted to copy extracts of these test result without the written permission of the test laboratory.



Contents

1. TEST STANDARDS	4
2. SUMMARY	5
2.1. General Remarks	5
2.2. Product Description	5
2.3. Equipment Under Test	5
2.4. EUT Classification:	6
2.5. Modifications	6
3. TEST ENVIRONMENT	7
3.1. Address of the test laboratory	7
3.2. Environmental conditions	7
3.3. Test Description	7
3.4. Statement of the measurement uncertainty	8
3.5. Equipments Used during the Test	9
4. TEST CONDITIONS AND RESULTS	11
4.1. ETSI EN 300 328 REQUIREMENTS	11
4.1.1. RF Output Power	11
4.1.2. Duty Cycle, TX-sequence, TX-gap	14
4.1.3. Dwell time, Min. Freq. Occupation and Hopping Sequence	16
4.1.4. Hopping Frequency Separation	19
4.1.5. Medium Utilisation (MU) factor	21
4.1.6. Adaptivity	22
4.1.7. Occupied Channel Bandwidth	25
4.1.8. Transmitter unwanted emissions in the out-of-band domain	27
4.1.9. Receiver Blocking	31
4.1.10. Geo-location capability	35
4.1.11. Transmitter unwanted emissions in the spurious domain	36
4.1.12. Receiver spurious emissions	40
5. PHOTOS OF THE EUT	42



1. TEST STANDARDS

The tests were performed according to following standards:

ETSI EN 300 328 V2.2.2 (2019-07)–Wideband transmission systems; Data transmission equipment operating in the 2,4 GHz band; Harmonised Standard for access to radio spectrum

Draft document



2. SUMMARY

2.1. General Remarks

Date of receipt of test sample	:	Feb.20,2023
Testing commenced on	:	Feb.20,2023
Testing concluded on	:	Feb.24,2023

2.2. Product Description

Product Name:	Bluetooth wireless speaker
Model/Type reference:	X26L
List Model:	Signature Speaker
Trade Mark:	COMISO
Power supply:	DC 3.7V/6000mAh From Battery and DC 5V/2A From External Circuit
Operation frequency	2402MHz-2480MHz
BT Modulation Type	GFSK,8DPSK, π /4DQPSK
Channel number:	79

2.3. Equipment Under Test

Power supply system utilised

Power supply voltage	:	<input type="radio"/> 230V/ 50 Hz	<input type="radio"/> 120V/60Hz
		<input type="radio"/> 12 V DC	<input type="radio"/> 24 V DC
		<input checked="" type="radio"/> Other : DC 3.7V	

Description of the test mode

Channel	Frequency(MHz)	Channel	Frequency(MHz)
00	2402	40	2442
01	2403	41	2443
02	2404	42	2444
03	2405	43	2445
04	2406	44	2446
05	2407	45	2447
06	2408	46	2448
07	2409	47	2449
08	2410	48	2450
09	2411	49	2451
10	2412	50	2452
11	2413	51	2453
12	2414	52	2454
13	2415	53	2455
14	2416	54	2456
15	2417	55	2457
16	2418	56	2458
17	2419	57	2459
18	2420	58	2460



19	2421	59	2461
20	2422	60	2462
21	2423	61	2463
22	2424	62	2464
23	2425	63	2465
24	2426	64	2466
25	2427	65	2467
26	2428	66	2468
27	2429	67	2469
28	2430	68	2470
29	2431	69	2471
30	2432	70	2472
31	2433	71	2473
32	2434	72	2474
33	2435	73	2475
34	2436	74	2476
35	2437	75	2477
36	2438	76	2478
37	2439	77	2479
38	2440	78	2480
39	2441		

2.4. EUT Classification:

Type of equipment:	<input checked="" type="checkbox"/>	stand alone equipment
	<input type="checkbox"/>	plug in radio equipment
	<input type="checkbox"/>	combined equipment
Modulation types:	<input type="checkbox"/>	Wide Band Modulation (None Hopping – e.g. DSSS, OFDM)
	<input checked="" type="checkbox"/>	Frequency Hopping Spread Spectrum (FHSS)
Adaptive equipment:	<input checked="" type="checkbox"/>	Yes, LBT-based
	<input type="checkbox"/>	Yes, non-LBT-based
	<input type="checkbox"/>	Yes (but can be disabled)
	<input type="checkbox"/>	No
Antennas and transmit operating modes:	<input checked="" type="checkbox"/>	Operating mode 1 (single antenna) Equipment with 1 antenna, Equipment with 2 diversity antennas operating in switched diversity mode by which at any moment in time only 1 antenna is used, Smart antenna system with 2 or more transmit/receive chains, but operating in a mode where only 1 transmit/receive chain is used)
	<input type="checkbox"/>	Operating mode 2 (multiple antennas, no beamforming) Equipment operating in this mode contains a smart antenna system using two or more transmit/receive chains simultaneously but without beamforming.
	<input type="checkbox"/>	Operating mode 3 (multiple antennas, with beamforming) Equipment operating in this mode contains a smart antenna system using two or more transmit/receive chains simultaneously with beamforming. In addition to the antenna assembly gain (G), the beamforming gain (Y) may have to be taken into account when performing the measurements.

2.5. Modifications

No modifications were implemented to meet testing criteria.



3. TEST ENVIRONMENT

3.1. Address of the test laboratory

Shenzhen HTT Technology Co., Ltd.

1F, B Building, Huafeng International Robotics Industrial Park, Gushu, Xixiang Street, Bao'an District, Shenzhen

3.2. Environmental conditions

During the measurement the environmental conditions were within the listed ranges:

Normal Temperature: 25 °C

High Temperature: 55 °C

Low Temperature: -20 °C

Normal Voltage : DC 3.7V

Relative Humidity: 55 %

Air Pressure: 989 hPa

3.3. Test Description

3.3.1 Main Terms

Verdict

Verdict of each test cases.

3.3.4 Summary of measurement results

No deviations from the technical specifications were ascertained

There were deviations from the technical specifications ascertained

Test Specific ation Clause	Test Case	Test Condition	Mode	Pass	Fail	N/A	NP	Remark
5.4.2	RF output power	NTC	GFSK	<input checked="" type="checkbox"/>	<input type="checkbox"/>	<input type="checkbox"/>	<input type="checkbox"/>	
		LT	$\pi/4$ DQPSK	<input checked="" type="checkbox"/>	<input type="checkbox"/>	<input type="checkbox"/>	<input type="checkbox"/>	
		HT	8 DPSK	<input checked="" type="checkbox"/>	<input type="checkbox"/>	<input type="checkbox"/>	<input type="checkbox"/>	
5.4.2	Duty Cycle, Tx- sequence, Tx- gap	NTC	---	<input type="checkbox"/>	<input type="checkbox"/>	<input checked="" type="checkbox"/>	<input type="checkbox"/>	
5.4.4	Dwell time, min Freq. Occu- pation and Hopping se- quence	NTC	GFSK $\pi/4$ DQPSK 8 DPSK	<input checked="" type="checkbox"/>	<input type="checkbox"/>	<input type="checkbox"/>	<input type="checkbox"/>	
5.4.5	Hopping Separ- ation	NTC	GFSK $\pi/4$ DQPSK 8 DPSK	<input checked="" type="checkbox"/>	<input type="checkbox"/>	<input type="checkbox"/>	<input type="checkbox"/>	
5.4.2	Medium Utilisa- tion	NTC	---	<input type="checkbox"/>	<input type="checkbox"/>	<input checked="" type="checkbox"/>	<input type="checkbox"/>	
5.4.6	Adaptivity, Short Controls ignalling Trans- missions	NTC	GFSK $\pi/4$ DQPSK 8 DPSK	<input type="checkbox"/>	<input type="checkbox"/>	<input checked="" type="checkbox"/>	<input type="checkbox"/>	
5.4.7	Occupied Cha- nnel Bandwid- th	NTC	GFSK $\pi/4$ DQPSK 8 DPSK	<input checked="" type="checkbox"/>	<input type="checkbox"/>	<input type="checkbox"/>	<input type="checkbox"/>	
5.4.8	Transmitter un- wanted emissi- ons in the out- of- band domain	NTC	GFSK $\pi/4$ DQPSK 8 DPSK	<input checked="" type="checkbox"/>	<input type="checkbox"/>	<input type="checkbox"/>	<input type="checkbox"/>	
		LT		<input checked="" type="checkbox"/>	<input type="checkbox"/>	<input type="checkbox"/>	<input type="checkbox"/>	
		HT		<input checked="" type="checkbox"/>	<input type="checkbox"/>	<input type="checkbox"/>	<input type="checkbox"/>	
5.4.9	Transmitter un-	NTC	GFSK	<input checked="" type="checkbox"/>	<input type="checkbox"/>	<input type="checkbox"/>	<input type="checkbox"/>	



	wanted emissions in the spurious domain (conducted & radiated)		$\pi/4$ DQPSK 8 DPSK					
5.4.10	Receiver spurious emissions (conducted & radiated)	NTC	GFSK $\pi/4$ DQPSK 8 DPSK	<input checked="" type="checkbox"/>	<input type="checkbox"/>	<input type="checkbox"/>	<input type="checkbox"/>	
5.4.11	Receiver Blocking	NTC	----	<input checked="" type="checkbox"/>	<input type="checkbox"/>	<input type="checkbox"/>	<input type="checkbox"/>	

Remark: The measurement uncertainty is not included in the test result.

3.4. Statement of the measurement uncertainty

The data and results referenced in this document are true and accurate. The reader is cautioned that there may be errors within the calibration limits of the equipment and facilities. The measurement uncertainty was calculated for all measurements listed in this test report acc. to TR-100028-01 "Electromagnetic compatibility and Radio spectrum Matters (ERM); Uncertainties in the measurement of mobile radio equipment characteristics; Part 1" and TR-100028-02 "Electromagnetic compatibility and Radio spectrum Matters (ERM); Uncertainties in the measurement of mobile radio equipment characteristics; Part 2" and is documented in the Shenzhen HTT Technology Co., Ltd. quality system acc. to DIN EN ISO/IEC 17025. Furthermore, component and process variability of devices similar to that tested may result in additional deviation. The manufacturer has the sole responsibility of continued compliance of the device.

Hereafter the best measurement capability for Shenzhen HTT Technology Co., Ltd. is reported:

Test Items	Measurement Uncertainty	Notes
Frequency error	25 Hz	(1)
Frequency range	25 Hz	(1)
Transmitter power conducted	0.57 dB	(1)
Transmitter power Radiated	2.20 dB	(1)
Adjacent and alternate channel power Conducted	1.20 dB	(1)
Conducted spurious emission	1.60 dB	(1)
Radiated spurious emission	2.20 dB	(1)
Intermodulation attenuation	1.00 dB	(1)
Maximum useable receiver sensitivity	2.80 dB	(1)
Co-channel rejection	2.80 dB	(1)
Adjacent channel selectivity	2.80 dB	(1)
Spurious response rejection	2.80 dB	(1)
Intermodulation response rejection	2.80 dB	(1)
Blocking or desensitization	2.80 dB	(1)

(1) This uncertainty represents an expanded uncertainty expressed at approximately the 95% confidence level using a coverage factor of k=2.



3.5 Equipments Used during the Test

RF output power&PSD&OOB&OBW &Hoping &Duty Cycle, Tx-sequence, Tx-gap&Adaptively& ReceiverBlocking						
Item	Test Equipment	Manufacturer	Model No.	Serial No.	Calibration Date	Calibration Due Date
1	Spectrum Analyzer	Agilent	N9020A	MY48010425	2022/05/23	2023/05/22
2	Vector Signal generator	Agilent	N5181A	MY49060502	2022/05/23	2023/05/22
3	Signal generator	Agilent	E4421B	3610AO1069	2022/05/23	2023/05/22
4	4 Ch. Simultaneous Sampling 14 Bits 2 MS/s	Agilent	U2531A	TW53323507	2022/05/23	2023/05/22
5	X-series USB Peak and Average Power Sensor	Agilent	U2021XA	MY5365004	2022/05/23	2023/05/22
6	Climate Chamber	ESPEC	EL-10KA	A20120523	2022/05/23	2023/05/22
7	Universal Radio Communication	Rohde&Schwarz	CMU200	114353	2022/05/23	2023/05/22
8	Wireless Communication Tester	Rohde&Schwarz	CMW500	125408	2022/05/23	2023/05/22
9	Test Control Unit	Tonscend	JS0806-1	178060067	2022/05/23	2023/05/22
10	Automated filter bank	Tonscend	JS0806-F	19F8060177	2022/05/23	2023/05/22
11	EMI Test software	Tonscend	JS1120-1	Ver 2.6.8.0518	/	/
12	EMI Test software	Tonscend	JS1120-3	Ver 2.5.77.0418	/	/



Transmitter spurious emissions & Receiver spurious emissions						
Item	Test Equipment	Manufacturer	Model No.	Serial No.	Calibration Date	Calibration Due Date
1	EMI Test Receiver	ROHDE & SCHWARZ	ESCI 7	101102	2022/05/23	2023/05/22
2	Spectrum Analyzer	Agilent	N9020A	MY480 10425	2022/05/23	2023/05/22
3	Spectrum Analyzer	R&S	FSV40	100019	2022/05/23	2023/05/22
4	By-log Antenna	SCHWARZBECK	VULB9163	000976	2022/05/23	2023/05/22
5	Double Ridged Horn Antenna (1~18GHz)	SCHWARZBECK	BBHA 9120D	01622	2022/05/23	2023/05/22
6	Horn Antenna (18GHz~40GHz)	Schwarzbeck	BBHA9170	791	2022/05/23	2023/05/22
7	Amplifier (30MHz~1GHz)	Schwarzbeck	BBV 9743	#202	2022/05/23	2023/05/22
8	Amplifier (1GHz~18GHz)	Taiwan Chengyi	EMC051845 B	980355	2022/05/23	2023/05/22
9	Amplifier (26.5GHz~40GHz)	Schwarzbeck	BBV9179	9719- 025	2022/05/23	2023/05/22
10	High-Pass Filter	K&L	9SH10- 2700/X1275 0-O/O	KL1420 31	2022/05/23	2023/05/22
11	High-Pass Filter	K&L	41H10- 1375/U1275 0-O/O	KL1420 32	2022/05/23	2023/05/22
12	RF Cable	HUBER+SUHNER	RG214	N/A	2022/05/23	2023/05/22
13	EMI Test software	Tonscend	JS32-RE	Ver 2.5.1.8	/	/

The calibration interval is 1 year.

4. TEST CONDITIONS AND RESULTS

4.1. ETSI EN 300 328 REQUIREMENTS

4.1.1. RF Output Power

LIMIT

ETSI EN 300 328 Sub-clause 4.3.1.2.3

The maximum RF output power for adaptive Frequency Hopping equipment shall be equal to or less than 20 dBm.

The maximum RF output power for non-adaptive Frequency Hopping equipment shall be declared by the supplier. See clause 5.3.1 m). The maximum RF output power for this equipment shall be equal to or less than the value declared by the supplier. This declared value shall be equal to or less than 20 dBm.

The RF output power is defined as the mean equivalent isotropically radiated power (e.i.r.p.) of the equipment during a transmission burst.

TEST CONFIGURATION



TEST PROCEDURE

Please refer to ETSI EN 300 328 Sub-clause 5.4.2.2.1

Step 1:

- Use a fast power sensor suitable for 2.4 GHz and capable of 1 MS/s.
 - Use the following settings:
 - Sample speed 1 MS/s or faster.
 - The samples must represent the power of the signal.
 - Measurement duration: For non-adaptive equipment: equal to the observation period defined in clauses 4.3.1.2.1 or 4.3.2.3.1. For adaptive equipment, the measurement duration shall be long enough to ensure a minimum number of bursts (at least 10) are captured.
- NOTE 1: For adaptive equipment, to increase the measurement accuracy, a higher number of bursts may be used.

Step 2:

- For conducted measurements on devices with one transmit chain:
Connect the power sensor to the transmit port, sample the transmit signal and store the raw data. Use these stored samples in all following steps.
- For conducted measurements on devices with multiple transmit chains:
Connect one power sensor to each transmit port for a synchronous measurement on all transmit ports. Trigger the power sensors so that they start sampling at the same time. Make sure the time difference between the samples of all sensors is less than half the time between two samples.
For each instant in time, sum the power of the individual samples of all ports and store them. Use these stored samples in all following steps.

Step 3:

- Find the start and stop times of each burst in the stored measurement samples.
NOTE 2: The start and stop times are defined as the points where the power is at least 20 dB below the RMS burst power calculated in step 4.

Step 4:

- Between the start and stop times of each individual burst calculate the RMS power over the burst. Save these P_{burst} values, as well as the start and stop times for each burst.

Step 5:

- The highest of all P_{burst} values (value "A" in dBm) will be used for maximum e.i.r.p. calculations.

**Step 6:**

- Add the (stated) antenna assembly gain "G" in dBi of the individual antenna.
- If applicable, add the additional beamforming gain "Y" in dB.
- If more than one antenna assembly is intended for this power setting, the maximum overall antenna gain (G or G + Y) shall be used.
- The RF Output Power (P) shall be calculated using the formula below:

$$P = A + G + Y$$
- This value, which shall comply with the limit given in clause 4.3.1.2.3 or clause 4.3.2.2.3, shall be recorded in the test report.

EUT DESCRIPTION:

Mode:	Testmode
Hopping:	On
Packet Type:	Longest supported
Modulation:	GFSK, $\Pi/4$ DQPSK, 8DPSK

MEASUREMENT DESCRIPTION

Instrument:	Power Meter measuring burst Power(EMS) of a least 10 packets	
Performed:	<input checked="" type="checkbox"/>	Conducted
	<input type="checkbox"/>	Radiated (only if no conducted sample is provided)

TEST RESULTS

Test Mode: GFSK Mode				
Antenna Gain: 1.00 dBi		Test Method: Conducted		
Test Condition		Maximum conducted Burst Power in 15 measured Bursts (RMS) [dBm]		
Test environmental				
Temperature (°C)	Voltage (V)	Measured Power (dBm)	Antenna Gain(dBi)	EIRP (dBm)
T Nor (25°C)	3.70	3.89	1.00	4.89
T min (-20°C)	3.70	3.97	1.00	4.97
T Max (+55°C)	3.70	3.79	1.00	4.79
Result Limit		Pass 20dBm		

Test Mode: $\pi/4$ QPSK Mode				
Antenna Gain: 1.00 dBi		Test Method: Conducted		
Test Condition		Maximum conducted Burst Power in 15 measured Bursts (RMS) [dBm]		
Test environmental				
Temperature (°C)	Voltage (V)	Measured Power (dBm)	Antenna Gain(dBi)	EIRP (dBm)
T Nor (25°C)	3.70	3.13	1.00	4.13
T min (-20°C)	3.70	3.24	1.00	4.24
T Max (+55°C)	3.70	3.22	1.00	4.22
Result Limit		Pass 20dBm		



Test Mode:8DPSK Mode				
Antenna Gain:1.00 dBi		Test Method: Conducted		
Test Condition		Maximum conducted Burst Power in 15 measured Bursts (RMS) [dBm]		
Test environmental				
Temperature (°C)	Voltage (V)	Measured Power (dBm)	Antenna Gain(dBi)	EIRP (dBm)
T Nor (25°C)	3.70	2.46	1.00	3.46
T min (-20°C)	3.70	2.24	1.00	3.24
T Max (+55°C)	3.70	2.74	1.00	3.74
Result		Pass		
Limit		20dBm		

Note :1. Measured Power include the cable loss.

Draft document



4.1.2. Duty Cycle, TX-sequence, TX-gap

LIMIT

ETSI EN 300 328 Sub-clause 4.3.1.3

For non-adaptive FHSS equipment, the Duty Cycle shall be equal to or less than the maximum value declared by the supplier. In addition, the maximum Tx-sequence time shall be 5 ms while the minimum Tx-gap time shall be 5 ms.

These requirements apply to non-adaptive frequency hopping equipment or to adaptive frequency hopping equipment operating in a non-adaptive mode.

These requirements do not apply for equipment with a maximum declared RF Output power of less than 10 dBm e.i.r.p. or for equipment when operating in a mode where the RF Output power is less than 10 dBm e.i.r.p.

Medical devices requiring reverse compatibility with other medical devices placed on the market when earlier versions of the present document were harmonised, are allowed to have an operating mode in which they do not have to comply with the requirements for Duty Cycle, Tx-sequence and Tx-gap.

TEST PROCEDURE

Please refer to ETSI EN 300 328 Sub-clause 5.4.2.2.1.

The test procedure, which shall only be performed for non-adaptive systems and only to be performed at normal environmental conditions, shall be as follows:

Step 1:

- Use the same stored measurement samples from the procedure described in clause 5.4.2.2.1.3

Step 2:

- Between the saved start and stop times of each individual burst, calculate the TxOn time. Save these TxOn values.
- Between the saved stop and start times of two subsequent bursts, calculate the TxOff time. Save these TxOff values.

Step 3:

- Duty Cycle is the sum of all TxOn times divided by the observation period defined in clauses 4.3.1.3.2 or clause 4.3.2.4.2
- For equipment using blacklisting, the TxOn time measured for a single (and active) hopping frequency shall be multiplied by the number of blacklisted frequencies. This value shall be added to the sum calculated in the previous bullet point. If the number of blacklisted frequencies cannot be determined, the minimum number of hopping frequencies as defined in clause 4.3.1.4.3 shall be assumed.
- The above calculated value for Duty Cycle shall be recorded in the test report. This value shall be equal to or less than the maximum value declared by the supplier.

Step 4:

- Use the same stored measurement samples from the procedure described in clause 5.4.2.2.1.3
- Identify any TxOff time that is equal to or greater than the minimum Tx-gap time as defined in clause 4.3.1.3.3 or clause 4.3.2.4.3. These are the potential valid gap times to be further considered in this procedure.
- Starting from the second identified gap, calculate the time from the start of this gap to the end of the preceding gap. This time is the Tx-sequence time for this transmission. Repeat this procedure until the last identified gap within the observation period is reached.
- Any Tx-sequence time shall be less than or equal to the maximum range defined in clause 4.3.1.3.3 or clause 4.3.2.4.3 and followed by a Tx-gap time that is equal to or greater than its preceding Tx-sequence time.
- A combination of consecutive Tx-sequence times and Tx-gap times followed by a Tx-gap time, which is at least as long as the duration of this combination, may be considered as a single Tx-sequence time and in which case it shall comply with the limits defined in clause 4.3.1.3.3 or clause 4.3.2.4.3.
- It shall be noted in the test report whether the UUT complies with the limits defined in clause 4.3.1.3.3 or clause 4.3.2.4.3.

EUT DESCRIPTION:

Mode:	BT Testmode
Hopping:	On
Packet Type:	Longest supported
Modulation:	GFSK, $\Pi/4$ DQPSK, 8DPSK



MEASUREMENT DESCRIPTION

Instrument:	Power Meter measuring average burst Power of a least 10 packets	
Performed:	<input checked="" type="checkbox"/>	Conducted
	<input type="checkbox"/>	Radiated (only if no conducted sample is provided)

TEST RESULTS

This requirement do not apply for equipment with a maximum declared RF Output power level of less than 10 dBme.i.r.p. or for equipment when operating in a mode where the RF Output power is less than 10 dBme.i.r.p. So This requirement do not apply for EUT.

Draft document



4.1.3. Dwell time, Min. Freq. Occupation and Hopping Sequence

LIMIT

ETSI EN 300 328 Sub-clause 4.3.1.4.3.2

Adaptive frequency hopping systems:

Adaptive Frequency Hopping systems shall be capable of operating over a minimum of 70 % of the band specified in clause 1.

The maximum accumulated dwell time on any hopping frequency shall be 400 ms within any period of 400 ms multiplied by the minimum number of hopping frequencies (N) that have to be used.

The hopping sequence(s) shall contain at least N hopping frequencies at all times, where N is 15 or 15 divided by the minimum Hopping Frequency Separation in MHz, whichever is the greater.

The Minimum Frequency Occupation Time shall be equal to one dwell time within a period not exceeding four times the product of the dwell time per hop and the number of hopping frequencies in use.

TEST PROCEDURE

Please refer to ETSI EN 300 328 Sub-clause 5.4.4.2.1

These measurements shall only be performed at normal test conditions.

Step 1:

- The output of the transmitter shall be connected to a spectrum analyzer or equivalent.

- The analyzer shall be set as follows:

Centre Frequency: Equal to the hopping frequency being investigated

Frequency Span: 0 Hz

RBW: 500KHz (50 % of the Occupied Channel Bandwidth (single hop))

VBW: 500KHz (VBW \geq RBW)

Detector Mode: RMS

Sweep time: Equal to the Dwell Time \times Minimum number of hopping frequencies (N) (see clause 4.3.1.4.3.2)

Number of sweep points: 30 000

Trace mode: Clear / Write

Trigger: Free Run

Step 2:

- Save the trace data to a file for further analysis by a computing device using an appropriate software application or program.

Step 3:

- Identify the data points related to the frequency being investigated by applying a threshold.

The data points resulting from transmissions on the hopping frequency being investigated are assumed to have much higher levels compared to data points resulting from transmissions on adjacent hopping frequencies. If a clear determination between these transmissions is not possible, the RBW in step 1 shall be further reduced. In addition, a channel filter may be used.

- Count the number of data points identified as resulting from transmissions on the frequency being investigated and multiply this number by the time difference between two consecutive data points.

Step 4:

- The result in step 3 is the Accumulated Transmit Time which shall comply with the limit provided in clause 4.3.1.4.3.1 or clause 4.3.1.4.3.2 and which shall be recorded in the test report.

Step 5:

- Make the following changes on the analyzer and repeat steps 2 and 3.

Sweep time: $4 \times$ Dwell Time \times Actual number of hopping frequencies in use

the hopping frequencies occupied by the equipment without having transmissions during the dwell time (blacklisted frequencies) should be taken into account in the actual number of hopping frequencies in use. If this number cannot be determined (number of blacklisted frequencies unknown) it shall be assumed that the equipment uses the maximum possible number of hopping frequencies.

- The result shall be compared to the limit for the Frequency Occupation defined in clause 4.3.1.4.3.1 or clause 4.3.1.4.3.2. The result of this comparison shall be recorded in the test report.

Step 6:



●Make the following changes on the analyzer:

Start Frequency: 2 400 MHz

Stop Frequency: 2 483.5 MHz

RBW:500KHz(50 % of the Occupied Channel Bandwidth (single hop))

VBW:500KHz(VBW ≥ RBW)

Detector Mode: RMS

Sweep time: Auto

Trace Mode: Max Hold

Trigger: Free Run

●When the trace has completed, identify the number of hopping frequencies used by the hopping sequence.

●The result shall be compared to the limit (value N) defined in clause 4.3.1.4.3.1 or clause 4.3.1.4.3.2. This value shall be recorded in the test report..

For equipment with blacklisted frequencies, it might not be possible to verify the number of hopping frequencies in use. However they shall comply with the requirement for Accumulated Transmit Time and Frequency Occupation assuming the minimum number of hopping frequencies (N) defined in clause 4.3.1.4.3.1 or clause 4.3.1.4.3.2 is used.

Step 7:

●For adaptive systems, using the lowest and highest -20 dB points from the total spectrum envelope obtained in step 6, it shall be verified whether the system uses 70 % of the band specified in clause 1. The result shall be recorded in the test report.

EUT DESCRIPTION:

Dwell Time:

Definition: The Dwell Time is the time that a particular hopping frequency would be occupied by the transmitter during a single hop. The equipment itself is not required to transmit on this hopping frequency during the Dwell Time.

Minimum Frequency Occupation Time:

Definition: The Minimum Frequency Occupation Time is the minimum time each hopping frequency shall be occupied within a given period.

Requirement: The Minimum Frequency Occupation Time shall be equal to one dwell time within a period

Hopping Sequence:

Definition: The Hopping Sequence of a Frequency Hopping system is the unrepeated pattern of the hopping frequencies used by the equipment.

Requirement a): The hopping sequence(s) shall contain at least N hopping frequencies at all times, where N is 15 or 15 divided by the minimum Hopping Frequency Separation in MHz, whichever is the greater.

According to the Bluetooth Core Specification physical channels use at least $N_{min} = 20$ RF channels

Requirement b): Adaptive Frequency Hopping systems shall be capable of operating over a minimum of 70 % of the band.

Bandwidth ISM Band: 83.5 MHz, Used Bandwidth: 79MHz

TEST RESULTS

◆ **Dwell time**

Modulation	Channel	Packet	Accumulated Dwell Time (ms)	Limit (second)	Measurement Time(ms)	Result
GFSK	0	DH5	56.36	0.40	6000.00	Pass
	78		63.88		6000.00	
$\pi/4$ QPSK	0	2DH5	62.64	0.40	6000.00	Pass
	78		58.49		6000.00	
8DPSK	0	3DH5	74.75	0.40	6000.00	Pass
	78		76.36		6000.00	

◆ **Minimum frequency occupation**

Modulation	Channel	Packet	Minimum Frequency Occupation(ms)	Limit (ms)	Measurement Time(ms)	Result
GFSK	0	DH5	11.46	>0	4740	Pass
	78		11.78		4740	
$\pi/4$ QPSK	0	2DH5	11.25	>0	4740	Pass
	78		12.64		4740	
8DPSK	0	3DH5	10.44	>0	4740	Pass
	78		10.58		4740	

◆ **Hopping Sequence**

Modulation	Number of Hopping Frequencies	Limit	Band Allocation(%)	Limit Band Allocation(%)	Result
GFSK	79	≥ 15	95.13	$\geq 70\%$	Pass
$\pi/4$ QPSK	79	≥ 15	95.24		
8DPSK	79	≥ 15	95.25		



4.1.4. Hopping Frequency Separation

LIMIT

ETSI EN 300 328 Sub-clause 4.3.1.5.3.2

For Adaptive frequency hopping systems, The minimum Hopping Frequency Separation shall be 100 kHz. These measurements shall only be performed at normal test conditions and the measurement shall be performed on 2 adjacent hopping frequencies. The frequencies on which the test was performed shall be recorded

TEST PROCEDURE

Please refer to ETSI EN 300 328 Sub-clause 5.4.4.2.1

Option 1

Step 1:

- The output of the transmitter shall be connected to a spectrum analyzer or equivalent.
- The analyzer shall be set as follows:

Centre Frequency: Centre of the two adjacent hopping frequencies

Frequency Span: Sufficient to see the complete power envelope of both hopping frequencies

RBW: 100KHz

VBW: 300KHz

Detector Mode: RMS

Trace Mode: Max Hold

Sweep time: Auto

Step 2:

- Allow the trace to stabilize.
- Use the marker function of the analyser to define the lower- and the upper -20 dB points for both hopping frequencies M7061 and F2. This will result in M7061_L and M7061_H for hopping frequency M7061 and in F2_L and F2_H for hopping frequency F2. These values shall be recorded in the report.

Step 3:

- Calculate the centre frequencies M7061_C and F2_C for both hopping frequencies using the formulas below. These values shall be recorded in the report.

$$F1_C = \frac{F1_L + F1_H}{2} \quad F2_C = \frac{F2_L + F2_H}{2}$$

- Calculate the -20 dB channel bandwidth (BW_{CHAN}) using the formula below. This value shall be recorded in the report.

$$BW_{CHAN} = M7061_H - M7061_L$$

- Calculate the Hopping Frequency Separation (FHS) using the formula below. This value shall be recorded in the report.

$$FHS = F2_C - M7061_C$$

- Compare the measured Hopping Frequency Separation with the limit defined in clause 4.3.1.5.3. In addition, for non-Adaptive Frequency Hopping equipment, the Hopping Frequency Separation shall be equal to or greater than the -20 dB channel bandwidth or:

$$FHS \geq BW_{CHAN}$$

Step 4:

For adaptive systems, in case of overlapping channels which will prevent the definition of the -20 dB reference points M7061_H and F2_L, a higher reference level (e.g. -10 dB or -6 dB) may be chosen to define the reference points M7061_L; M7061_H; F2_L and F2_H.

Alternatively, special test software may be used to:

- force the UUT to hop or transmit on a single Hopping Frequency by which the -20 dB reference points can be measured separately for the 2 adjacent Hopping Frequencies; and/or
- force the UUT to operate without modulation by which the centre frequencies M7061_C and F2_C can be measured directly.

**Option 2****Step 1:**

- The output of the transmitter shall be connected to a spectrum analyzer or equivalent.
- The analyzer shall be set as follows:
 - Centre Frequency: Centre of the two adjacent hopping frequencies
 - Frequency Span: Sufficient to see the complete power envelope of both hopping frequencies
 - RBW: 100KHz
 - VBW: 300KHz
 - Detector Mode: RMS
 - Trace Mode: Max Hold
 - Sweep Time: Auto

Step 2:

- Allow the trace to stabilize.
- Use the marker-delta function to determine the Hopping Frequency Separation between the peaks of the two adjacent hopping frequencies. This value shall be compared with the limits defined in clause 4.3.1.5.3 and shall be recorded in the test report.

EUT DESCRIPTION:

Mode:	BT Testmode
Hopping:	On
Packet Type:	Longest supported
Modulation:	GFSK, $\pi/4$ DQPSK, 8DPSK

MEASUREMENT DESCRIPTION

Instrument:	Spectrum Analyzer	
Detector:	RMS	
Sweep time:	auto	
Video bandwidth:	100 KHz	
Resolution bandwidth:	300 KHz	
Span:	2.5 MHz	
Trace:	Max hold	
Performed:	<input checked="" type="checkbox"/>	Conducted
	<input type="checkbox"/>	Radiated (only if no conducted sample is provided)

TEST RESULTS

Modulation	Hopping Frequency Separation(MHz)	Limit(MHz)	Result
DH5	0.999	≥ 0.100000	Pass
2DH5	1.000	≥ 0.100000	Pass
3DH5	0.998	≥ 0.100000	Pass



4.1.5. Medium Utilisation (MU) factor

LIMIT

ETSI EN 300 328 Sub-clause 4.3.1.6.3

The maximum Medium Utilisation factor for non-adaptive Frequency Hopping equipment shall be 10 %. This requirement does not apply to adaptive equipment unless operating in a non-adaptive mode. In addition, this requirement does not apply for equipment with a maximum declared RF Output power level of less than 10 dBm e.i.r.p. or for equipment when operating in a mode where the RF Output power is less than 10 dBm e.i.r.p.

TEST PROCEDURE

Please refer to ETSI EN 300 328 Sub-clause 5.3.2.2.1.4

Step 1:

- Use the same stored measurement samples from the procedure described in clause 5.4.2.2.1.4

Step 2:

- For each burst calculate the product of ($P_{burst}/100$ mW) and the TxOn time.

NOTE: P_{burst} is expressed in mW. TxOn time is expressed in ms.

Step 3:

- Medium Utilization is the sum of all these products divided by the observation period (expressed in ms) which is defined in clause 4.3.1.3.2 or clause 4.3.2.4.2. This value, which shall comply with the limit given in clause 4.3.1.6.3 or clause 4.3.2.5.3, shall be recorded in the test report.

MEASUREMENT DESCRIPTION

Instrument:	Power Meter measuring average burst Power of a least 10 packets	
Performed:	<input checked="" type="checkbox"/>	Conducted
	<input type="checkbox"/>	Radiated (only if no conducted sample is provided)

TEST RESULTS

This requirement do not apply for equipment with a maximum declared RF Output power level of less than 10 dBme.i.r.p. or for equipment when operating in a mode where the RF Output power is less than 10 dBme.i.r.p. So This requirement do not apply for EUT



4.1.6. Adaptivity

Requirements & Limits

ETSI EN 300 328 Sub-4.3.1.7

The frequency range of the equipment is determined by the lowest and highest Non-LBT based Detect and Avoid

1. During normal operation, the equipment shall evaluate the presence of a signal on its current operating channel. If it is determined that a signal is present with a level above the detection threshold defined in step 5 the channel shall be marked as 'unavailable'
2. The channel shall remain unavailable for a minimum time equal to 1 second after which the channel may be considered again as an 'available' channel;
3. $COT \leq 40$ ms;
4. Idle Period = 5% of COT of the Channel Occupancy Time with a minimum of 100 μ s; After this, the procedure as in step 1 needs to be repeated.
5. Detection threshold level = $-70\text{dBm/MHz} + (20\text{dBm} - P_{out \text{ e.i.r.p}})/1\text{MHz}$ (P_{out} in dBm);

LBT based Detect and Avoid (Frame Based Equipment):

1. Minimum Clear Channel Assessment (CCA) time ≥ 18 μ s;
2. The equipment is allowed to continue Short Control Signalling Transmissions on this channel providing it complies with the requirements given in clause 4.3.2.6.4 (If implemented, Short Control Signalling Transmissions of adaptive equipment using wide band modulations other than FHSS shall have a maximum TxOn / (TxOn + TxOff) ratio of 10 % within any observation period of 50 ms.);
3. $COT = 1 \sim 10$ ms; Idle Period = 5% of COT;
4. Control frames are allowed but data frames are not allowed; $CCA \leq COT$;
5. Detection threshold level = $-70\text{dBm/MHz} + (20\text{dBm} - P_{out \text{ e.i.r.p}})/1\text{MHz}$ (P_{out} in dBm);

LBT based Detect and Avoid (Load Based Equipment):

1. Minimum Clear Channel Assessment (CCA) time ≥ 18 μ s;
2. The equipment is allowed to continue Short Control Signalling Transmissions on this channel providing it complies with the requirements given in clause 4.3.2.6.4 (If implemented, Short Control Signalling Transmissions of adaptive equipment using wide band modulations other than FHSS shall have a maximum TxOn / (TxOn + TxOff) ratio of 10 % within any observation period of 50 ms.);
3. $COT \leq 13$ ms, after which the device shall perform a new CCA as described in step 1
4. Control frames are allowed but data frames are not allowed; $CCA \leq COT$;
5. Detection threshold level = $-70\text{dBm/MHz} + (20\text{dBm} - P_{out \text{ e.i.r.p}})/1\text{MHz}$ (P_{out} in dBm).

Unwanted Signal

Adaptive equipment using wide band modulations other than FHSS, shall comply with the requirements defined in clause 4.3.2.6.2 (non-LBT based DAA) or clause 4.3.2.6.3 (LBT based DAA) in the presence of a blocking signal with characteristics as provided in below.

Unwanted Signal parameters

Wanted signal mean power from companion device	Unwanted signal frequency (MHz)	Unwanted CW signal power (dBm)
sufficient to maintain the link (see note 2)	2 395 or 2 488,5 (see note 1)	-35 (see note 3)
<p>NOTE 1: The highest frequency shall be used for testing operating channels within the range 2 400 MHz to 2 442 MHz, while the lowest frequency shall be used for testing operating channels within the range 2 442 MHz to 2 483,5 MHz. See clause 5.4.6.1.</p> <p>NOTE 2: A typical value which can be used in most cases is -50 dBm/MHz.</p> <p>NOTE 3: The level specified is the level in front of the UUT antenna. In case of conducted measurements, this level has to be corrected by the actual antenna assembly gain.</p>		

TEST CONFIGURATION

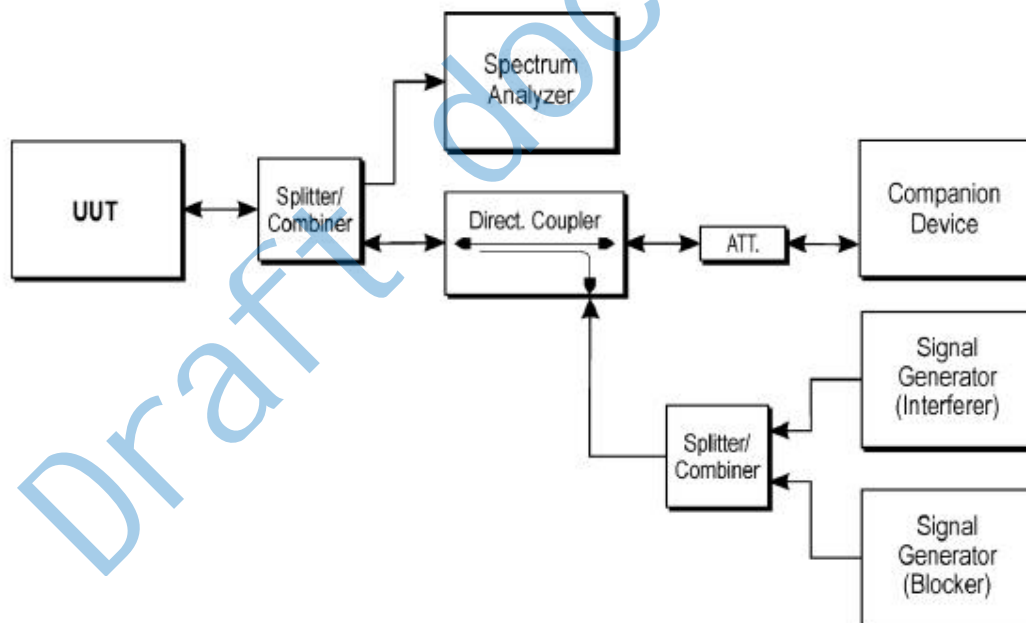

TEST PROCEDURE

1. Please refer to ETSI EN 300 328 Sub-clause 5.4.6.2.1 for the measurement method.

RBW: \geq Occupied Channel Bandwidth (if the analyser does not support this setting, the highest available setting shall be used) (10MHz)

VBW: $3 \times$ RBW (if the analyser does not support this setting, the highest available setting shall be used) (10MHz)

Detector Mode: RMS

Centre Frequency: Equal to the centre frequency of the operating channel

Span: 0 Hz

Sweep time: $>$ Channel Occupancy Time of the UUT

Trace Mode: Clear/Write



TEST RESULTS

This requirement do not apply for equipment with a maximum declared RF Output power level of less than 10 dBme.i.r.p. or for equipment when operating in a mode where the RF Output power is less than 10 dBm e.i.r.p. So This requirement do not apply for EUT

Draft document



4.1.7. Occupied Channel Bandwidth

LIMIT

ETSI EN 300 328 Sub-clause 4.3.1.8.3

The Occupied Channel Bandwidth for each hopping frequency shall fall completely within the band given in clause 1.

For non-adaptive Frequency Hopping equipment with e.i.r.p greater than 10 dBm, the Occupied Channel Bandwidth for every occupied hopping frequency shall be equal to or less than the value declared by the supplier. This declared value shall not be greater than 5 MHz.

The Occupied Channel Bandwidth is the bandwidth that contains 99 % of the power of the signal.

These measurements shall only be performed at normal test conditions.

In case of conducted measurements on smart antenna systems (equipment with multiple transmit chains) measurements need only to be performed on one of the active transmit chains (antenna outputs).

For systems using FHSS modulation and which have overlapping channels, special software might be required to force the UUT to hop or transmit on a single Hopping Frequency.

The measurement shall be performed only on the lowest and the highest frequency within the stated frequency range. The frequencies on which the test were performed shall be recorded.

If the equipment can operate with different Occupied Channel Bandwidths (e.g. 20 MHz and 40 MHz), then each channel bandwidth shall be tested separately.

TEST PROCEDURE

Please refer to ETSI EN 300 328 Sub-clause 5.4.7.2.1

Step 1:

Connect the UUT to the spectrum analyser and use the following settings:

- Centre Frequency: The centre frequency of the channel under test
- Resolution BW: ~ 1 % of the span without going below 1 %
- Video BW: 3 × RBW
- Frequency Span: 2 × Occupied Channel Bandwidth (e.g. 40 MHz for a 20 MHz channel)
- Detector Mode: RMS
- Trace Mode: Max Hold

Step 2:

Wait until the trace is completed.

Find the peak value of the trace and place the analyser marker on this peak.

Step 3:

Use the 99 % bandwidth function of the spectrum analyser to measure the Occupied Channel Bandwidth of the UUT. This value shall be recorded.

NOTE: Make sure that the power envelope is sufficiently above the noise floor of the analyser to avoid the noise signals left and right from the power envelope being taken into account by this measurement.

EUT DESCRIPTION:

Mode:	BT Testmode
Hopping:	Off
Packet Type:	Longest supported
Modulation:	GFSK, $\Pi/4$ DQPSK, 8DPSK

MEASUREMENT DESCRIPTION

Instrument:	Spectrum Analyzer	
Detector:	RMS	
Sweep time:	auto	
Video bandwidth:	100KHz	
Resolution bandwidth:	30KHz	
Span:	2 MHz	
Center:	Transmit channel	
Trace:	Max hold	
Performed:	<input checked="" type="checkbox"/>	Conducted
	<input type="checkbox"/>	Radiated (only if no conducted sample is provided)

**TEST RESULTS**

Modulation	Channel	Occupied Channel Bandwidth (MHz)	Result
DH5	CH0	0.97	Pass
	CH78	0.92	
2DH5	CH0	1.13	
	CH78	1.14	
3DH5	CH0	1.09	
	CH78	1.10	

Mode	Channel 00 FL(MHz)	Channel 78 FH(MHz)	Limits (MHz)	Verdict
DH5	2402	2480	FL \geq 2400MHz and FH \leq 2483.5MHz	PASS
2DH5	2402	2480	FL \geq 2400MHz and FH \leq 2483.5MHz	PASS
3DH5	2402	2480	FL \geq 2400MHz and FH \leq 2483.5MHz	PASS

4.1.8. Transmitter unwanted emissions in the out-of-band domain

LIMIT

ETSI EN 300 328 Sub-clause 4.3.1.9.3

The transmitter unwanted emissions in the out-of-band domain but outside the allocated band, shall not exceed the values provided by the mask in figure 1.

NOTE: Within the 2 400 MHz to 2 483,5 MHz band, the Out-of-band emissions are fulfilled by compliance with the Occupied Channel Bandwidth requirement in clause 4.3.1.8.

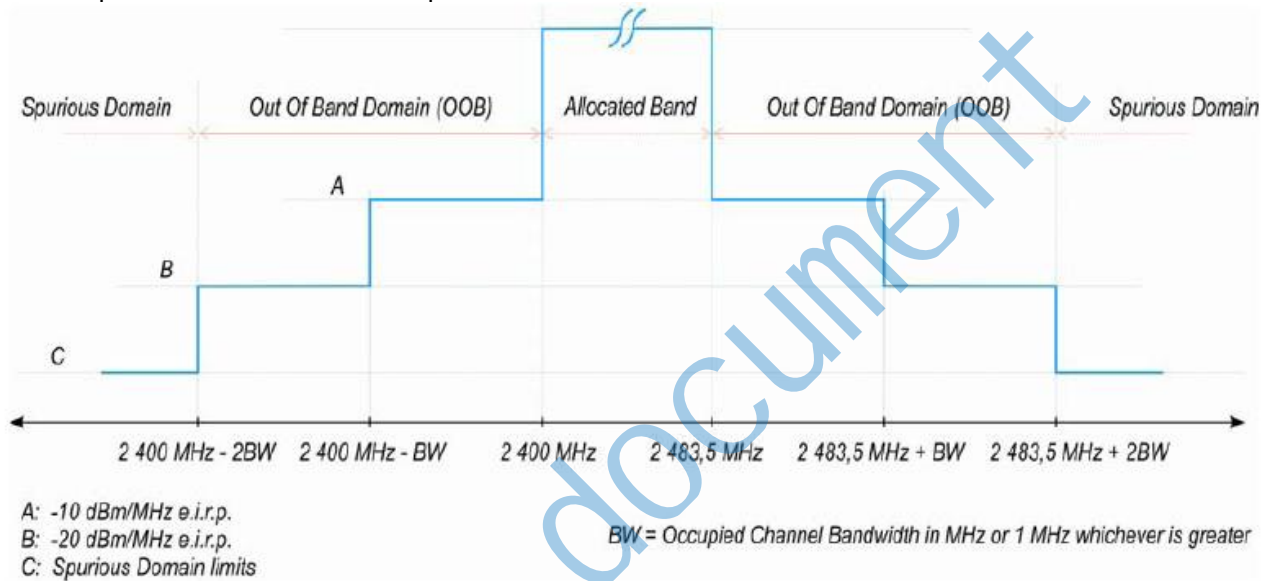

Figure 1: Transmit mask

Transmitter unwanted emissions in the out-of-band domain are emissions when the equipment is in Transmit mode, on frequencies immediately outside the necessary bandwidth which results from the modulation process, but excluding spurious.

These measurements have to be performed at normal environmental conditions and shall be repeated at the extremes of the operating temperature range.

In the case of equipment intended for use with an integral antenna and where no external (temporary) antenna connectors are provided, a test fixture as described in clause B.3 may be used to perform relative measurements at the extremes of the operating temperature range.

For systems using FHSS modulation, the measurements shall be performed during normal operation (hopping).

For systems using wide band modulations other than FHSS, the measurement shall be performed at the lowest and the highest channel on which the equipment can operate. These frequencies shall be recorded. The equipment shall be configured to operate under its worst case situation with respect to output power. If the equipment can operate with different Occupied Channel Bandwidths (e.g. 20 MHz and 40 MHz), then each channel bandwidth shall be tested separately.

TEST PROCEDURE

Please refer to ETSI EN 300 328 Sub-clause 5.4.8.2.1

The Out-of-band emissions within the different horizontal segments of the mask provided in figures 1 and 3 shall be measured using the steps below. This method assumes the spectrum analyser is equipped with the Time Domain Power option.

Step 1:

Connect the UUT to the spectrum analyser and use the following settings:

- Centre Frequency: The centre frequency of the channel under test

Centre Frequency: 2 484 MHz

Span: 0 Hz

Resolution BW: 1 MHz



Filter mode: Channel filter

Video BW: 3 MHz

Detector Mode: RMS

Trace Mode: Clear / Write

Sweep Mode: Continuous

Sweep Points: 5 000

Trigger Mode: Video trigger

NOTE 1: In case video triggering is not possible, an external trigger source may be used.

Sweep Time: Suitable to capture one transmission burst

Step 2:(segment 2 483,5 MHz to 2 483,5 MHz + BW)

- Adjust the trigger level to select the transmissions with the highest power level.
- For frequency hopping equipment operating in a normal hopping mode, the different hops will result in signal bursts with different power levels. In this case the burst with the highest power level shall be selected.
- Set a window (start and stop lines) to match with the start and end of the burst and in which the RMS power shall be measured using the Time Domain Power function.
- Select RMS power to be measured within the selected window and note the result which is the RMS power within this 1 MHz segment (2 483,5 MHz to 2 484,5 MHz). Compare this value with the applicable limit provided by the mask.
- Increase the centre frequency in steps of 1 MHz and repeat this measurement for every 1 MHz segment within the range 2 483,5 MHz to 2 483,5 MHz + BW. The centre frequency of the last 1 MHz segment shall be set to 2 483,5 MHz + BW - 0,5 MHz (which means this may partly overlap with the previous 1 MHz segment).

Step 3:(segment 2 483,5 MHz + BW to 2 483,5 MHz + 2BW)

- Change the centre frequency of the analyser to 2 484 MHz + BW and perform the measurement for the first 1 MHz segment within range 2 483,5 MHz + BW to 2 483,5 MHz + 2BW. Increase the centre frequency in 1 MHz steps and repeat the measurements to cover this whole range. The centre frequency of the last 1 MHz segment shall be set to 2 483,5 MHz + 2 BW - 0,5 MHz.

Step 4: (segment 2 400 MHz - BW to 2 400 MHz)

- Change the centre frequency of the analyser to 2 399,5 MHz and perform the measurement for the first 1 MHz segment within range 2 400 MHz - BW to 2 400 MHz. Reduce the centre frequency in 1 MHz steps and repeat the measurements to cover this whole range. The centre frequency of the last 1 MHz segment shall be set to 2 400 MHz - 2BW + 0,5 MHz.

Step 5: (segment 2 400 MHz - 2BW to 2 400 MHz - BW)

- Change the centre frequency of the analyser to 2 399,5 MHz - BW and perform the measurement for the first 1 MHz segment within range 2 400 MHz - 2BW to 2 400 MHz - BW. Reduce the centre frequency in 1 MHz steps and repeat the measurements to cover this whole range. The centre frequency of the last 1 MHz segment shall be set to 2 400 MHz - 2BW + 0,5 MHz.

Step 6:

- In case of conducted measurements on equipment with a single transmit chain, the declared antenna assembly gain "G" in dBi shall be added to the results for each of the 1 MHz segments and compared with the limits provided by the mask given in figures 1 or 3. If more than one antenna assembly is intended for this power setting, the antenna with the highest gain shall be considered.

- In case of conducted measurements on smart antenna systems (equipment with multiple transmit chains), the measurements need to be repeated for each of the active transmit chains. The declared antenna assembly gain "G" in dBi for a single antenna shall be added to these results. If more than one antenna assembly is intended for this power setting, the antenna with the highest gain shall be considered.

Comparison with the applicable limits shall be done using any of the options given below:

Option 1: the results for each of the transmit chains for the corresponding 1 MHz segments shall be added.

The additional beamforming gain "Y" in dB shall be added as well and the resulting values compared with the limits provided by the mask given in figures 1 or 3.

Option 2: the limits provided by the mask given in figures 1 or 3 shall be reduced by $10 \times \log_{10}(\text{Ach})$ and the additional beamforming gain "Y" in dB. The results for each of the transmit chains shall be individually compared with these reduced limits

NOTE 2: Ach refers to the number of active transmit chains.

EUT DESCRIPTION:



Mode:	BT Testmode
Hopping:	On
Packet Type:	Longest supported
Modulation:	GFSK, $\Pi/4$ DQPSK, 8DPSK

MEASUREMENT DESCRIPTION

Instrument:	Spectrum Analyzer	
Detector:	RMS	
Sweep time:	depending on packet length	
Video bandwidth:	3MHz	
Resolution bandwidth:	1MHz	
Span:	0Hz	
Center:	fc (see result table)	
Trace:	Trigger to burst	
Sweep points:	5000	
Performed:	<input checked="" type="checkbox"/>	Conducted
	<input type="checkbox"/>	Radiated (only if no conducted sample is provided)

TEST RESULTS

GFSK Modulation						
Test conditions		Frequency range (MHz)		Level (dBm)	Limit (dBm)	Result
Temperature (°C)	Voltage (V)	Start	Stop			
T _{nor} =25	3.70	2400-2OBW	2400-OBW	*	-20	Pass
		2400-OBW	2400	*	-10	Pass
		2484	2484+OBW	*	-10	Pass
		2484+OBW	2484+2OBW	*	-20	Pass
T _{low} =-20	3.70	2400-2OBW	2400-OBW	*	-20	Pass
		2400-OBW	2400	*	-10	Pass
		2484	2484+OBW	*	-10	Pass
		2484+OBW	2484+2OBW	*	-20	Pass
T _{high} =+55	3.70	2400-2OBW	2400-OBW	*	-20	Pass
		2400-OBW	2400	*	-10	Pass
		2484	2484+OBW	*	-10	Pass
		2484+OBW	2484+2OBW	*	-20	Pass



<i>π/4QPSK Modulation</i>						
<i>Test conditions</i>		<i>Frequency range (MHz)</i>		<i>Level (dBm)</i>	<i>Limit (dBm)</i>	<i>Result</i>
<i>Temperature (°C)</i>	<i>Voltage (V)</i>	<i>Start</i>	<i>Stop</i>			
<i>T_{nor}=25</i>	3.70	2400-2OBW	2400-OBW	*	-20	Pass
		2400-OBW	2400	*	-10	Pass
		2484	2484+OBW	*	-10	Pass
		2484+OBW	2484+2OBW	*	-20	Pass
<i>T_{low}=-20</i>	3.70	2400-2OBW	2400-OBW	*	-20	Pass
		2400-OBW	2400	*	-10	Pass
		2484	2484+OBW	*	-10	Pass
		2484+OBW	2484+2OBW	*	-20	Pass
<i>T_{high}=+55</i>	3.70	2400-2OBW	2400-OBW	*	-20	Pass
		2400-OBW	2400	*	-10	Pass
		2484	2484+OBW	*	-10	Pass
		2484+OBW	2484+2OBW	*	-20	Pass

<i>8DPSK Modulation</i>						
<i>Test conditions</i>		<i>Frequency range (MHz)</i>		<i>Level (dBm)</i>	<i>Limit (dBm)</i>	<i>Result</i>
<i>Temperature (°C)</i>	<i>Voltage (V)</i>	<i>Start</i>	<i>Stop</i>			
<i>T_{nor}=25</i>	3.70	2400-2OBW	2400-OBW	*	-20	Pass
		2400-OBW	2400	*	-10	Pass
		2484	2484+OBW	*	-10	Pass
		2484+OBW	2484+2OBW	*	-20	Pass
<i>T_{low}=-20</i>	3.70	2400-2OBW	2400-OBW	*	-20	Pass
		2400-OBW	2400	*	-10	Pass
		2484	2484+OBW	*	-10	Pass
		2484+OBW	2484+2OBW	*	-20	Pass
<i>T_{high}=+55</i>	3.70	2400-2OBW	2400-OBW	*	-20	Pass
		2400-OBW	2400	*	-10	Pass
		2484	2484+OBW	*	-10	Pass
		2484+OBW	2484+2OBW	*	-20	Pass

Note:* Radiant level is far less than the limit, has more than 20 dB margin

4.1.9. Receiver Blocking

Limits

ETSI EN 300 328 Sub-4.3.1.12.4

While maintaining the minimum performance criteria as defined in clause 4.3.1.12.3, the blocking levels at specified frequency offsets shall be equal to or greater than the limits defined for the applicable receiver category provided in in follow

Receiver Category 1

Wanted signal mean power from companion device (dBm) (see notes 1 and 4)	Blocking signal frequency (MHz)	Blocking signal power (dBm) (see note 4)	Type of blocking signal
(-133 dBm + 10 × log ₁₀ (OCBW)) or -68 dBm whichever is less (see note 2)	2 380 2 504		CW
(-139 dBm + 10 × log ₁₀ (OCBW)) or -74 dBm whichever is less (see note 3)	2 300 2 330 2 360 2 524 2 584 2 674	-34	
<p>NOTE 1: OCBW is in Hz.</p> <p>NOTE 2: In case of radiated measurements using a companion device and the level of the wanted signal from the companion device cannot be determined, a relative test may be performed using a wanted signal up to $P_{min} + 26$ dB where P_{min} is the minimum level of wanted signal required to meet the minimum performance criteria as defined in clause 4.3.1.12.3 in the absence of any blocking signal.</p> <p>NOTE 3: In case of radiated measurements using a companion device and the level of the wanted signal from the companion device cannot be determined, a relative test may be performed using a wanted signal up to $P_{min} + 20$ dB where P_{min} is the minimum level of wanted signal required to meet the minimum performance criteria as defined in clause 4.3.1.12.3 in the absence of any blocking signal.</p> <p>NOTE 4: The level specified is the level at the UUT receiver input assuming a 0 dBi antenna assembly gain. In case of conducted measurements, this level has to be corrected for the (in-band) antenna assembly gain (G). In case of radiated measurements, this level is equivalent to a power flux density (PFD) in front of the UUT antenna with the UUT being configured/positioned as recorded in clause 5.4.3.2.2.</p>			

Receiver Category 2

Wanted signal mean power from companion device (dBm) (see notes 1 and 3)	Blocking signal frequency (MHz)	Blocking signal power (dBm) (see note 3)	Type of blocking signal
(-139 dBm + 10 × log ₁₀ (OCBW) + 10 dB) or (-74 dBm + 10 dB) whichever is less (see note 2)	2 380 2 504 2 300 2 584	-34	CW
<p>NOTE 1: OCBW is in Hz.</p> <p>NOTE 2: In case of radiated measurements using a companion device and the level of the wanted signal from the companion device cannot be determined, a relative test may be performed using a wanted signal up to P_{min} + 26 dB where P_{min} is the minimum level of wanted signal required to meet the minimum performance criteria as defined in clause 4.3.1.12.3 in the absence of any blocking signal.</p> <p>NOTE 3: The level specified is the level at the UUT receiver input assuming a 0 dBi antenna assembly gain. In case of conducted measurements, this level has to be corrected for the (in-band) antenna assembly gain (G). In case of radiated measurements, this level is equivalent to a power flux density (PFD) in front of the UUT antenna with the UUT being configured/positioned as recorded in clause 5.4.3.2.2.</p>			

Receiver Category 3

Wanted signal mean power from companion device (dBm) (see notes 1 and 3)	Blocking signal frequency (MHz)	Blocking signal power (dBm) (see note 3)	Type of blocking signal
(-139 dBm + 10 × log ₁₀ (OCBW) + 20 dB) or (-74 dBm + 20 dB) whichever is less (see note 2)	2 380 2 504 2 300 2 584	-34	CW
<p>NOTE 1: OCBW is in Hz.</p> <p>NOTE 2: In case of radiated measurements using a companion device and the level of the wanted signal from the companion device cannot be determined, a relative the test may be performed using a wanted signal up to P_{min} + 30 dB where P_{min} is the minimum level of wanted signal required to meet the minimum performance criteria as defined in clause 4.3.1.12.3 in the absence of any blocking signal.</p> <p>NOTE 3: The level specified is the level at the UUT receiver input assuming a 0 dBi antenna assembly gain. In case of conducted measurements, this level has to be corrected for the (in-band) antenna assembly gain (G). In case of radiated measurements, this level is equivalent to a power flux density (PFD) in front of the UUT antenna with the UUT being configured/positioned as recorded in clause 5.4.3.2.2.</p>			

TEST CONFIGURATION

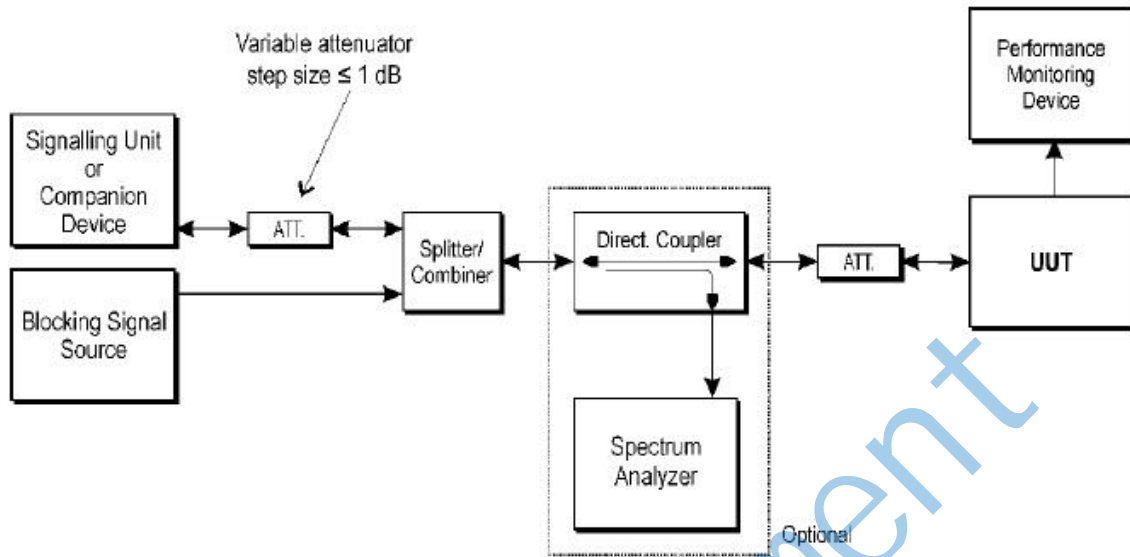

TEST PROCEDURE

Please refer to ETSI EN 300 328 Sub-clause 5.4.11.2.1 for the measurement method..

TEST RESULTS

The manufacturer declares that Pmin is -98dBm

For GFSK

According to Sub 4.2.3, The Power of the EUT is less than 10dBm, So it belongs to Receiver category 2

Test frequency	2402MHz		Test mode	Normal link	
Wanted signal mean power from companion device (dBm)	Blocking signal frequency (MHz)	Blocking signal power (dBm)	Limit(PER)	test value(PER)	Result
-139 dBm + 10 × log10(OCBW) + 10 dB	2380	-34	10%	3%	PASS
	2504		10%	4%	PASS
	2300		10%	3%	PASS
	2584		10%	3%	PASS

Test frequency	2480MHz		Test mode	Normal link	
Wanted signal mean power from companion device (dBm)	Blocking signal frequency (MHz)	Blocking signal power (dBm)	Limit(PER)	test value(PER)	Result
-139 dBm + 10 × log10(OCBW) + 10 dB	2380	-34	10%	3%	PASS
	2504		10%	3%	PASS
	2300		10%	4%	PASS
	2584		10%	4%	PASS



Forπ/4QPSK

According to Sub 4.2.3, The Power of the EUT is less than 10dBm, So it belongs to Receiver category 2

Test frequency	2402MHz		Test mode	Normal link	
Wanted signal mean power from companion device (dBm)	Blocking signal frequency (MHz)	Blocking signal power (dBm)	Limit(PER)	test value(PER)	Result
-139 dBm + 10 × log ₁₀ (OCBW) + 10 dB	2380	-34	10%	3%	PASS
	2504		10%	4%	PASS
	2300		10%	3%	PASS
	2584		10%	3%	PASS

Test frequency	2480MHz		Test mode	Normal link	
Wanted signal mean power from companion device (dBm)	Blocking signal frequency (MHz)	Blocking signal power (dBm)	Limit(PER)	test value(PER)	Result
-139 dBm + 10 × log ₁₀ (OCBW) + 10 dB	2380	-34	10%	3%	PASS
	2504		10%	4%	PASS
	2300		10%	4%	PASS
	2584		10%	3%	PASS

For8DPSK

According to Sub 4.2.3, The Power of the EUT is less than 10dBm, So it belongs to Receiver category 2

Test frequency	2402MHz		Test mode	Normal link	
Wanted signal mean power from companion device (dBm)	Blocking signal frequency (MHz)	Blocking signal power (dBm)	Limit(PER)	test value(PER)	Result
-139 dBm + 10 × log ₁₀ (OCBW) + 10 dB	2380	-34	10%	2%	PASS
	2504		10%	3%	PASS
	2300		10%	3%	PASS
	2584		10%	2%	PASS

Test frequency	2480MHz		Test mode	Normal link	
Wanted signal mean power from companion device (dBm)	Blocking signal frequency (MHz)	Blocking signal power (dBm)	Limit(PER)	test value(PER)	Result
-139 dBm + 10 × log ₁₀ (OCBW) + 10 dB	2380	-34	10%	2%	PASS
	2504		10%	3%	PASS
	2300		10%	3%	PASS
	2584		10%	2%	PASS



4.1.10. Geo-location capability

Requirements

ETSI EN 300 328 Sub-clause 4.3.1.13.3

Geo-location capability is a feature of the equipment to determine its geographical location with the purpose to configure itself according to the regulatory requirements applicable at the geographical location where it operates. The geo-location capability may be present in the equipment or in an external device (temporary) associated with the equipment operating at the same geographical location during the initial power up of the equipment. The geographical location may also be available in equipment already installed and operating at the same geographical location

The geographical location determined by the equipment as defined in clause 4.3.1.13.2 shall not be accessible to the user.

TEST RESULTS

This item is not applicable for the EUT

Draft document

4.1.11. Transmitter unwanted emissions in the spurious domain

LIMIT

ETSI EN 300 328 Sub-clause 4.3.1.10.3

The transmitter unwanted emissions in the spurious domain shall not exceed the values given in table 1

Table 1: Transmitter limits for spurious emissions

Frequency range	Maximum power, e.r.p. (≤ 1 GHz) e.i.r.p. (> 1 GHz)	Bandwidth
30 MHz to 47 MHz	-36 dBm	100 kHz
47 MHz to 74 MHz	-54 dBm	100 kHz
74 MHz to 87,5 MHz	-36 dBm	100 kHz
87,5 MHz to 118 MHz	-54 dBm	100 kHz
18 MHz to 174 MHz	-36 dBm	100 kHz
174 MHz to 230 MHz	-54 dBm	100 kHz
230 MHz to 470 MHz	-36 dBm	100 kHz
470 MHz to 694 MHz	-54 dBm	100 kHz
694 MHz to 1 GHz	-36 dBm	100 kHz
1 GHz to 12.75 GHz	-30 dBm	1 MHz

Transmitter unwanted emissions in the spurious domain are emissions outside the allocated band and outside the out-of-band domain as indicated in figure 1 when the equipment is in Transmit mode.

These measurements shall only be performed at normal test conditions.

For systems using FHSS modulation, the measurements may be performed when normal hopping is disabled. In this case measurements need to be performed when operating at the lowest and the highest hopping frequency. When this is not possible, the measurement shall be performed during normal operation (hopping). For systems using wide band modulations other than FHSS, the measurement shall be performed at the lowest and the highest channel on which the equipment can operate. These frequencies shall be recorded. The equipment shall be configured to operate under its worst case situation with respect to output power. If the equipment can operate with different Occupied Channel Bandwidths (e.g. 20 MHz and 40 MHz), then the equipment shall be configured to operate under its worst case situation with respect to spurious emissions.

TEST PROCEDURE

Please refer to ETSI EN 300 328 Sub-clause 5.4.9.2.1

In case of conducted measurements, the radio equipment shall be connected to the measuring equipment via a suitable attenuator.

The spectrum in the spurious domain (see figures 1 or 3) shall be searched for emissions that exceed the limit values given in tables 1 or 4 or that come to within 6 dB below these limits. Each occurrence shall be recorded.

Pre-scan

The test procedure below shall be used to identify potential unwanted emissions of the UUT.

Step 1:

The sensitivity of the spectrum analyser should be such that the noise floor is at least 12 dB below the limits given in tables 1 or 4.

Step 2:

The emissions over the range 30 MHz to 1 000 MHz shall be identified.

Spectrum analyser settings:

- Resolution bandwidth: 100 kHz
- Video bandwidth: 300 kHz
- Detector mode: Peak
- Trace Mode: Max Hold
- Sweep Points: $\geq 9\,970$

NOTE 1: For spectrum analysers not supporting this high number of sweep points, the frequency band may need to be segmented.

•Sweep time:

For non continuous transmissions (duty cycle less than 100 %), the sweep time shall be sufficiently long, such that for each 100 kHz frequency step, the measurement time is greater than two transmissions of the UUT.

For Frequency Hopping equipment operating in a normal operating (hopping not disabled) mode, the sweep time shall be further increased to capture multiple transmissions on the same hopping frequency in different hopping sequences.

Allow the trace to stabilize. Any emissions identified during the sweeps above and that fall within the 6 dB range below the applicable limit or above, shall be individually measured using the procedure in clause 5.3.10.2.1.3 and compared to the limits given in table 1 or table 4..

Step 3

The emissions over the range 1 GHz to 12,75 GHz shall be identified.

Spectrum analyser settings:

- Resolution bandwidth: 1 MHz
- Video bandwidth: 3 MHz
- Detector mode: Peak
- Trace Mode: Max Hold
- Sweep Points: $\geq 11\ 750$

NOTE 2: For spectrum analysers not supporting this high number of sweep points, the frequency band may need to be segmented.

•Sweep time:

For non continuous transmissions (duty cycle less than 100 %), the sweep time shall be sufficiently long, such that for each 1 MHz frequency step, the measurement time is greater than two transmissions of the UUT.

For Frequency Hopping equipment operating in a normal operating (hopping not disabled) mode, the sweep time shall be further increased to capture multiple transmissions on the same hopping frequency in different hopping sequences.

Allow the trace to stabilize. Any emissions identified during the sweeps above that fall within the 6 dB range below the applicable limit or above, shall be individually measured using the procedure in clause 5.4.9.2.1.3 and compared to the limits given in table 1 or table 4..

Frequency Hopping equipment may generate a block (or several blocks) of spurious emissions anywhere within the spurious domain. If this is the case, only the highest peak of each block of emissions shall be measured using the procedure in clause 5.4.9.2.1.3.

Step 4:

•In case of conducted measurements on smart antenna systems (equipment with multiple transmit chains), the steps 2 and 3 need to be repeated for each of the active transmit chains (Ach). The limits used to identify emissions during this pre-scan need to be reduced with $10 \times \log_{10}(\text{Ach})$ (number of active transmit chains).

Measurement of the emissions identified during the pre-scan

The steps below shall be used to accurately measure the individual unwanted emissions identified during the pre-scan measurements above.

Step 1:

The level of the emissions shall be measured using the following spectrum analyser settings:

- Centre Frequency: Frequency of emission identified during the pre-scan
- Resolution Bandwidth: 100 kHz (< 1 GHz) / 1 MHz (> 1 GHz)
- Video Bandwidth: 300 kHz (< 1 GHz) / 3 MHz (> 1 GHz)
- Frequency Span: Wide enough to capture each individual emission identified during the pre-scan
- Sweep mode: Continuous
- Sweep time: Auto
- Trigger: Free run
- Detector: RMS
- Trace Mode: Max Hold

Step 2:

In case of conducted measurements on smart antenna systems (equipment with multiple transmit chains), the step 1 needs to be repeated for each of the active transmit chains (Ach).

The trace data for each transmit chain has to be recorded.



Sum the power in each of the traces for each individual frequency bin.

Step 3:

Use the marker function to find the highest peak within the measurement trace and record its value and its frequency.

Step 4:

The measured values shall be compared to the limits defined in tables 1 and 4.

EUT DESCRIPTION:

Mode:	BT Testmode
Hopping:	Off, lowest & highest frequency
Packet Type:	Longest supported
Modulation:	GFSK, $\pi/4$ DQPSK, 8DPSK

MEASUREMENT DESCRIPTION

Instrument:	Spectrum Analyzer	
Detector:	Peak for prescan / RMS for emission retest	
Sweep time:	Auto	
Video bandwidth:	Below 1 GHz: 300 kHz / above 3MHz	
Resolution bandwidth:	Below 1 GHz: 100 kHz / above 1MHz	
Trace:	Max hold	
Sweep points:	40001	
Performed:	<input checked="" type="checkbox"/>	Conducted
	<input checked="" type="checkbox"/>	Radiated

TEST RESULTS**Pass**

Note :We tested the all modes, and recorded the worst case at the GFSK Mode.

Conducted Spurious Emissions

Measured Modulation	<input checked="" type="checkbox"/> GFSK	<input checked="" type="checkbox"/> $\pi/4$ DQPSK	<input checked="" type="checkbox"/> 8DPSK
---------------------	---	---	--

Radiation Spurious Emissions

Measured Modulation	<input checked="" type="checkbox"/> GFSK	<input checked="" type="checkbox"/> $\pi/4$ DQPSK	<input checked="" type="checkbox"/> 8DPSK
---------------------	---	---	--

**Conducted Spurious Emissions**

DH5				
Suspected List				
NO.	Freq. [MHz]	Result Level [dBm]	Limit [dBm]	Margin [dB]
1	4804.00	-50.02	-30.00	20.02
2	7206.00	-52.46	-30.00	22.46

DH5				
Suspected List				
NO.	Freq. [MHz]	Result Level [dBm]	Limit [dBm]	Margin [dB]
1	4960.000	-48.37	-30.00	18.37
2	7440.000	-51.33	-30.00	21.33

Radiation Spurious Emissions

DH5						
Low channel				Horizontal/ Vertical		
Suspected List						
NO.	Freq. [MHz]	Result Level [dBm]	Factor [dB]	Limit [dBm]	Margin [dB]	Polarity
1	4804.00	-50.47	14.03	-30.00	20.47	Horizontal
2	7206.00	-52.59	23.18	-30.00	22.59	Vertical

High channel				Horizontal/ Vertical		
Suspected List						
NO.	Freq. [MHz]	Result Level [dBm]	Factor [dB]	Limit [dBm]	Margin [dB]	Polarity
1	4960.000	-48.35	15.17	-30.00	18.35	Vertical
2	7440.000	-51.21	24.65	-30.00	21.21	Vertical



4.1.12. Receiver spurious emissions

LIMIT

ETSI EN 300 328 Sub-clause 4.3.1.11.3

The spurious emissions of the receiver shall not exceed the values given in table 2.

Table 2: Spurious emission limits for receivers

Frequency range	Maximum power.e.r.p. (≤ 1 GHz) e.i.r.p. (> 1 GHz)	Measurement bandwidth
30 MHz to 1 GHz	-57 dBm	100 kHz
1 GHz to 12,75 GHz	-47 dBm	1 MHz

These measurements shall only be performed at normal test conditions.

Testing shall be performed when the equipment is in a receive-only mode.

For systems using wide band modulations other than FHSS, the measurement shall be performed at the lowest and the highest channel on which the equipment can operate. These frequencies shall be recorded.

For systems using FHSS modulation, the measurements may be performed when normal hopping is disabled.

In this case measurements need to be performed when operating at the lowest and the highest hopping frequency. These frequencies shall be recorded. When disabling the normal hopping is not possible, the measurement shall be performed during normal operation (hopping).

TEST CONFIGURATION

The same as described in section 4.1.10

TEST PROCEDURE

The same as described in section 4.1.10

EUT DESCRIPTION:

Mode:	BT Receiver/Idle Mode
Hopping:	Off, lowest & highest frequency
Modulation:	GFSK, $\pi/4$ DQPSK, 8DPSK

MEASUREMENT DESCRIPTION

Instrument:	Spectrum Analyzer	
Detector:	Peak for prescan / RMS for emission retest	
Sweep time:	Auto	
Video bandwidth:	Below 1 GHz: 300 kHz / above 3MHz	
Resolution bandwidth:	Below 1 GHz: 100 kHz / above 1MHz	
Trace:	Max hold	
Sweep points:	40001	
Performed:	<input type="checkbox"/>	Conducted
	<input checked="" type="checkbox"/>	Radiated (only if no conducted sample is provided)

TEST RESULTS

Pass

Note :We tested the all modes,and recorded the worst case at the GFSK Mode.

Conducted Spurious Emissions

Measured Modulation	<input checked="" type="checkbox"/> GFSK	<input checked="" type="checkbox"/> $\pi/4$ DQPSK	<input checked="" type="checkbox"/> 8DPSK
---------------------	---	---	--

Radiation Spurious Emissions

Measured Modulation	<input checked="" type="checkbox"/> GFSK	<input checked="" type="checkbox"/> $\pi/4$ DQPSK	<input checked="" type="checkbox"/> 8DPSK
---------------------	---	---	--

**Conducted Spurious Emissions**

DH5				
Suspected List				
NO.	Freq. [MHz]	Result Level [dBm]	Limit [dBm]	Margin [dB]
1	45.528	-77.17	-57.00	20.17
2	197.241	-76.16	-57.00	19.16

DH5				
Suspected List				
NO.	Freq. [MHz]	Result Level [dBm]	Limit [dBm]	Margin [dB]
1	43.331	-76.99	-57.00	19.99
2	205.178	-77.75	-57.00	20.75

Radiation Spurious Emissions

DH5						
Low channel				Horizontal/ Vertical		
Suspected List						
NO.	Freq. [MHz]	Result Level [dBm]	Factor [dB]	Limit [dBm]	Margin [dB]	Polarity
1	45.528	-77.32	-0.51	-57.00	20.32	Vertical
2	197.241	-76.68	-5.34	-57.00	19.68	Horizontal
High channel				Horizontal/ Vertical		
Suspected List						
NO.	Freq. [MHz]	Result Level [dBm]	Factor [dB]	Limit [dBm]	Margin [dB]	Polarity
1	43.331	-76.26	-0.41	-57.00	19.26	Vertical
2	205.178	-77.49	-5.86	-57.00	20.49	Horizontal



5. Photos of the EUT

Reference to the test report No. HTT202302300E-1

.....**End of Report**.....

Draft document