

TEST REPORT

Report No.: BCTC2302060974-2E

Applicant: SHEN ZHEN AUDIO EM ELECTRONIC CO. LTD

Product Name: Wireless headphone

Model/Type
reference: OPP032

Tested Date: 2022-06-20 to 2022-06-27

Issued Date: 2023-02-28

Shenzhen BCTC Testing Co., Ltd.



Product Name: Wireless headphone
Trademark: N/A
Model/Type reference: OPP032
OPP032, OPP049, 700XHP
Prepared For: SHEN ZHEN AUDIO EM ELECTRONIC CO. LTD
Address: No. 3, zhugaotang Road, building 9, Dahuang Industrial Zone, Pinghu community,
Pinghu street, Longgang District, Shenzhen, China
Manufacturer: SHEN ZHEN AUDIO EM ELECTRONIC CO. LTD
Address: No. 3, zhugaotang Road, building 9, Dahuang Industrial Zone, Pinghu community,
Pinghu street, Longgang District, Shenzhen, China
Prepared By: Shenzhen BCTC Testing Co., Ltd.
Address: 1-2/F., Building B, Pengzhou Industrial Park, No.158, Fuyuan 1st Road,
Zhancheng, Fuhai Subdistrict, Bao'an District, Shenzhen, Guangdong, China.
Sample Received Date: 2022-06-20
Sample tested Date: 2022-06-20 to 2022-06-27
Issue Date: 2023-02-28
Report No.: BCTC2302060974-2E
Test Standards: ETSI EN 301 489-1 V2.2.3 (2019-11)
ETSI EN 301 489-17 V3.2.4 (2020-09)
Test Results: PASS
Remark: This is EMC test report

Tested by:



Eric Yang/Project Handler

Approved by:



Zero Zhou/Reviewer

The test report is effective only with both signature and specialized stamp. This result(s) shown in this report refer only to the sample(s) tested. Without written approval of Shenzhen BCTC Testing Co., Ltd, this report can't be reproduced except in full. The tested sample(s) and the sample information are provided by the client.

Table Of Content

| Test Report Declaration | Page |
|---|------|
| 1. Version | 5 |
| 2. Test Summary | 6 |
| 3. Measurement Uncertainty | 7 |
| 4. Product Information And Test Setup | 8 |
| 4.1 Product Information..... | 8 |
| 4.2 Test Setup Configuration | 8 |
| 4.3 Support Equipment | 8 |
| 4.4 Test Mode | 9 |
| 5. Test Facility And Test Instrument Used..... | 10 |
| 5.1 Test Facility..... | 10 |
| 5.2 Test Instrument Used..... | 10 |
| 6. Conducted Emissions..... | 12 |
| 6.1 Block Diagram Of Test Setup..... | 12 |
| 6.2 Limit | 12 |
| 6.3 Test procedure..... | 12 |
| 6.4 Test Result..... | 13 |
| 7. Radiated Emissions Test..... | 15 |
| 7.1 Block Diagram Of Test Setup..... | 15 |
| 7.2 Limits..... | 15 |
| 7.3 Test Procedure | 16 |
| 7.4 Test Results | 17 |
| 8. Harmonic Current Emission(H)..... | 19 |
| 8.1 Block Diagram of Test Setup | 19 |
| 8.2 Limit | 19 |
| 8.3 Test Procedure | 19 |
| 8.4 Test Results | 19 |
| 9. Voltage Fluctuations & Flicker(F) | 20 |
| 9.1 Block Diagram of Test Setup | 20 |
| 9.2 Limit | 20 |
| 9.3 Test Procedure | 20 |
| 9.4 Test Results | 20 |
| 10. Immunity Test Of General The Performance Criteria | 21 |
| 11. Electrostatic Discharge (ESD)..... | 23 |
| 11.1 Test Specification..... | 23 |
| 11.2 Block Diagram of Test Setup | 23 |
| 11.3 Test Procedure | 23 |
| 11.4 Test Results | 24 |
| 12. Continuous RF Electromagnetic Field Disturbances(RS)..... | 25 |
| 12.1 Test Specification..... | 25 |
| 12.2 Block Diagram of Test Setup | 25 |
| 12.3 Test Procedure | 26 |
| 12.4 Test Results | 26 |
| 13. Electrical Fast Transients/Burst (EFT)..... | 27 |
| 13.1 Test Specification..... | 27 |
| 13.2 Block Diagram of EUT Test Setup | 27 |

BCTC
 3C
 PPR
 检测

| | | |
|------|---|----|
| 13.3 | Test Procedure | 27 |
| 13.4 | Test Results | 27 |
| 14. | Surges Immunity Test | 28 |
| 14.1 | Test Specification..... | 28 |
| 14.2 | Block Diagram of EUT Test Setup | 28 |
| 14.3 | Test Procedure | 28 |
| 14.4 | Test Result..... | 28 |
| 15. | Continuous Induced RF Disturbances (CS) | 29 |
| 15.1 | Test Specification..... | 29 |
| 15.2 | Block Diagram of EUT Test Setup | 29 |
| 15.3 | Test Procedure | 29 |
| 15.4 | Test Result..... | 29 |
| 16. | Voltage Dips And Interruptions (DIPS) | 30 |
| 16.1 | Test Specification..... | 30 |
| 16.2 | Block Diagram of EUT Test Setup | 30 |
| 16.3 | Test Procedure | 30 |
| 16.4 | Test Result..... | 30 |
| 17. | EUT Photographs..... | 31 |
| 18. | EUT Test Setup Photographs..... | 35 |

(Note: N/A Means Not Applicable)

TE
TC
OVE
檢

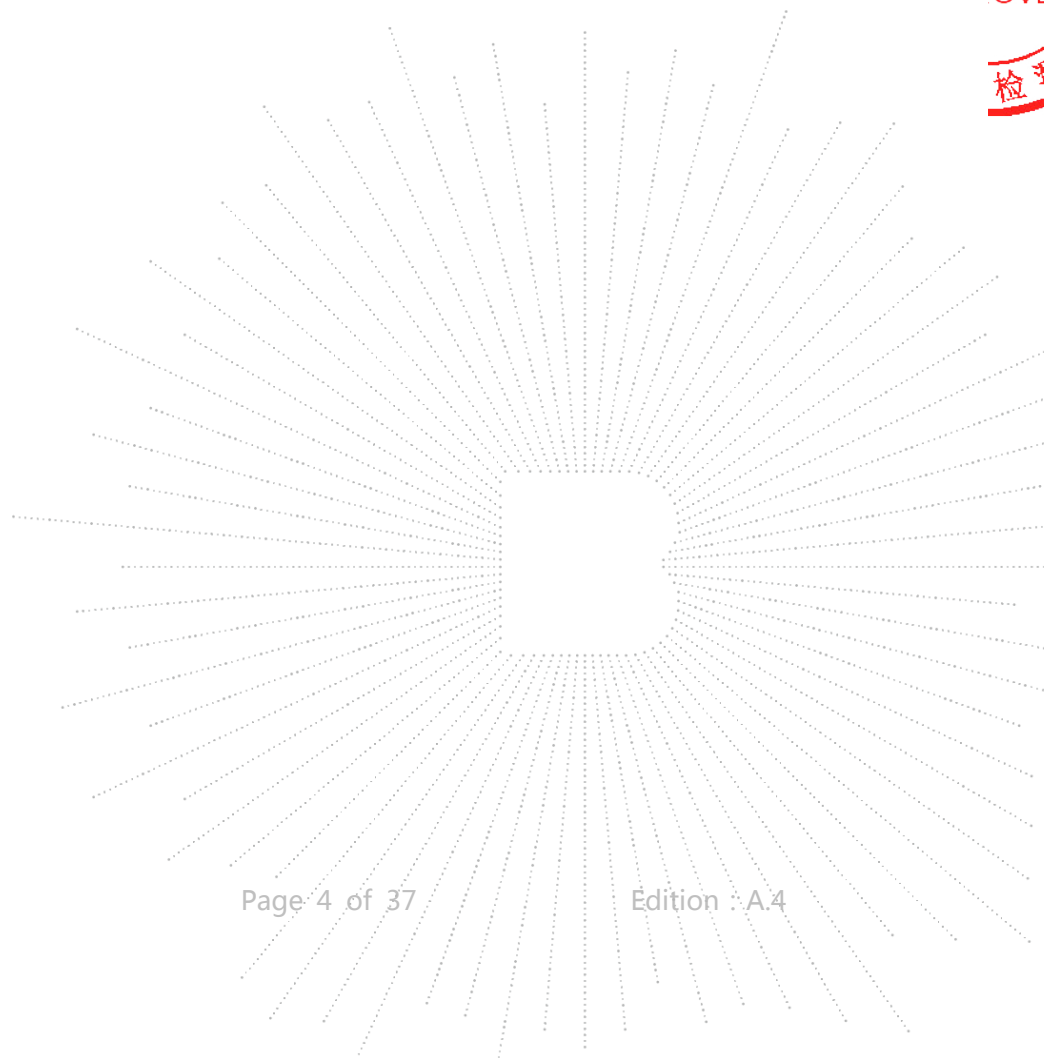

1. Version

| Report No. | Issue Date | Description | Approved |
|-------------------|------------|-------------|----------|
| BCTC2302060974-2E | 2023-02-28 | Original | Valid |
| | | | |

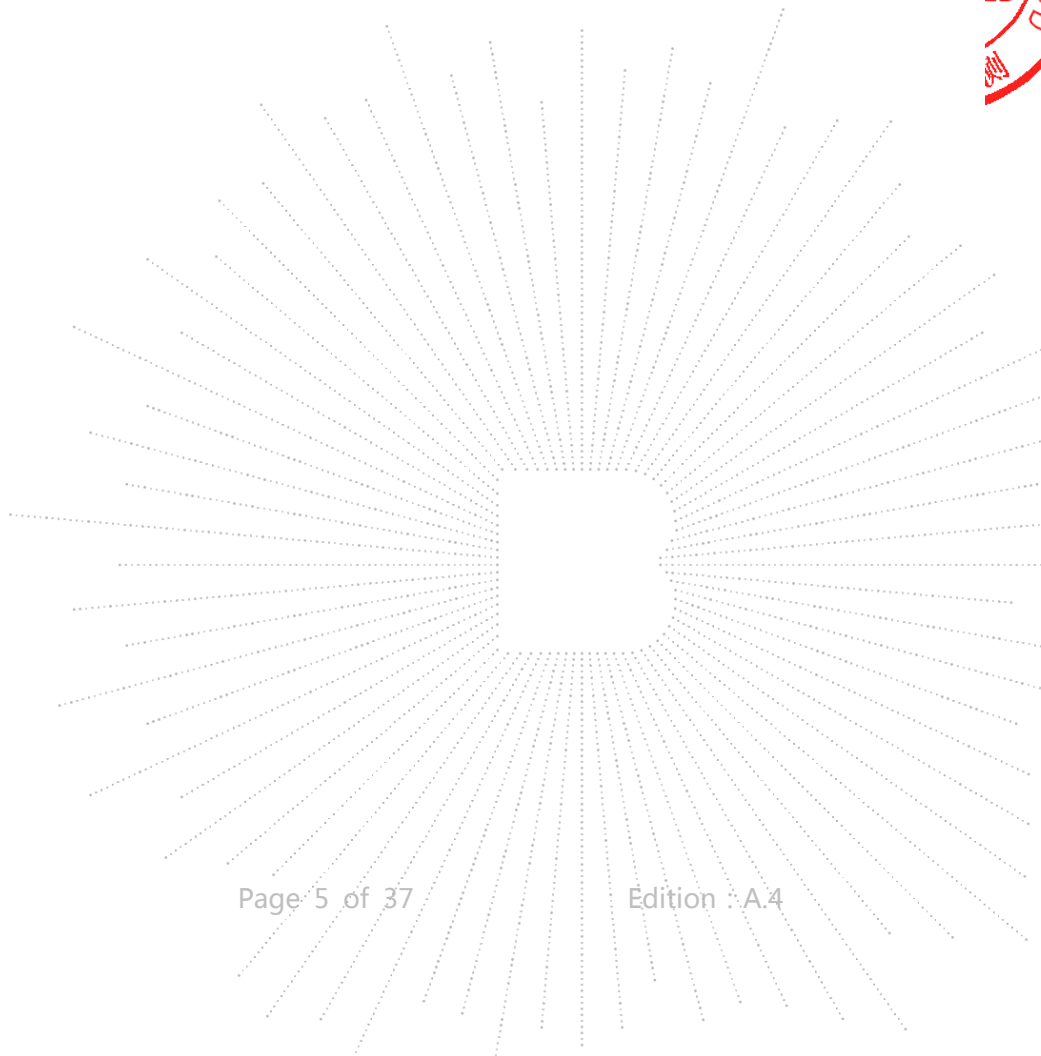

2. Test Summary

The Product has been tested according to the following specifications:

| Emission | | |
|--------------|---|------------------|
| Standard | Test Item | Test result |
| EN 301 489-1 | Conducted emissions from the AC mains power ports | Pass |
| EN 301 489-1 | Asymmetric mode conducted emissions | N/A ¹ |
| EN 301 489-1 | Conducted differential voltage emissions | N/A ² |
| EN 301 489-1 | Radiated emissions | Pass |
| EN 301 489-1 | Harmonic current emission(H) | N/A ³ |
| EN 301 489-1 | Voltage fluctuations & flicker(F) | N/A ³ |

| Immunity | | |
|--------------|--|------------------|
| Standard | Test Item | Test result |
| EN 301 489-1 | Electrostatic discharge (ESD) | Pass |
| EN 301 489-1 | Continuous RF electromagnetic field disturbances(RS) | Pass |
| EN 301 489-1 | Electrical fast transients/burst (EFT) | N/A ³ |
| EN 301 489-1 | Surges | N/A ³ |
| EN 301 489-1 | Radio frequency, common mode | N/A ³ |
| EN 301 489-1 | Voltage dips and interruptions (DIPS) | N/A ³ |

Remark:

1. Applicable to ports listed above and intended to connect to cables longer than 3 m.
2. The Product has no antenna port.
4. The EUT is powered by the DC only, the test item is not applicable.

Remark: Based on the following changes in the original test report (BCTC2206453553-2E), No changes were made to the product, Only changes Applicant Company, Applicant Address, Manufacturer Company, Manufacturer Address Model Name.

3. Measurement Uncertainty

Where relevant, the following measurement uncertainty levels have been estimated for tests performed on the Product as specified in CISPR 16-4-2. This uncertainty represents an expanded uncertainty expressed at approximately the 95% confidence level using a coverage factor of $k=2$.

| Test item | Value (dB) |
|-----------------------------------|------------|
| Conducted Emission (150kHz-30MHz) | 3.20 |
| Radiated Emission(30MHz~1GHz) | 4.80 |
| Radiated Emission(1GHz~6GHz) | 4.90 |



4. Product Information And Test Setup

4.1 Product Information

| | |
|-----------------------|---|
| Model/Type reference: | OPP032 OPP032, OPP049, 700XHP |
| Model differences: | All the model are the same circuit and RF module, except model names. |
| Hardware Version: | N/A |
| Software Version: | N/A |
| Operation Frequency: | Bluetooth(EDR): 2402-2480MHz |
| Max. RF output power: | Bluetooth(EDR): 0.37dBm |
| Type of Modulation: | Bluetooth(EDR): GFSK, $\pi/4$ DQPSK, 8DPSK |
| Antenna installation: | PCB antenna |
| Antenna Gain: | 2.71dBi |
| Ratings: | USB: DC 5V Battery: DC 3.7V |

4.2 Test Setup Configuration

See test photographs attached in EUT TEST SETUP PHOTOGRAPHS for the actual connections between Product and support equipment.

4.3 Support Equipment

| No. | Device Type | Brand | Model | Series No. | Note |
|-----|-------------|--------|-------|------------|------|
| 1. | Adapter | UGREEN | CD122 | --- | --- |

Notes:

- All the equipment/cables were placed in the worst-case configuration to maximize the emission during the test.
- Grounding was established in accordance with the manufacturer's requirements and conditions for the intended use.



4.4 Test Mode

| Test item | Test Mode | Test Voltage |
|--|-----------|---------------|
| Conducted emissions from the AC mains power ports (150KHz-30MHz) Class B | Charging | AC 230V/50Hz |
| Radiated emissions(30MHz-6GHz) Class B | Charging | AC 230V/50Hz* |
| | BT Link | DC 3.7V |
| Electrostatic discharge (ESD) <input checked="" type="checkbox"/> Air Discharge: $\pm 2,4,8\text{Kv}$ <input checked="" type="checkbox"/> Contact Discharge: $\pm 2,4\text{kV}$ <input checked="" type="checkbox"/> HCP & VCP: $\pm 2,4\text{kV}$ | Charging | AC 230V/50Hz |
| | BT Link | DC 3.7V |
| Continuous RF electromagnetic field disturbances(RS) <input checked="" type="checkbox"/> 80MHz-6000MHz , 3V/m,80% Front, Rear, Left, Right H/V | Charging | AC 230V/50Hz |
| | BT Link | DC 3.7V |
| All test mode were tested and passed, only Radiated Emissions shows (*) is the worst case mode which were recorded in this report. | | |

,TC
 3C
 PPR
 测

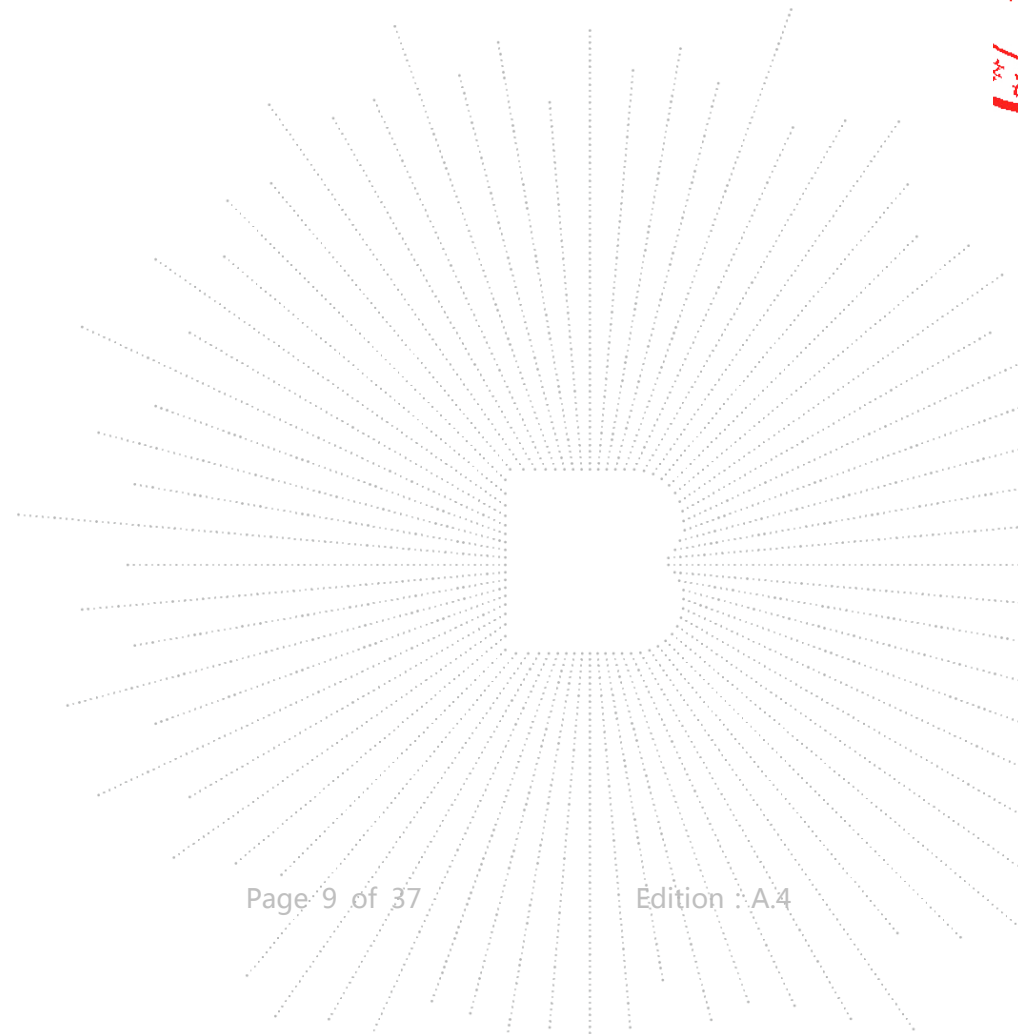

5. Test Facility And Test Instrument Used

5.1 Test Facility

All measurement facilities used to collect the measurement data are located at Shenzhen BCTC Testing Co., Ltd. Address: 1-2/F., Building B, Pengzhou Industrial Park, No.158, Fuyuan 1st Road, Zhancheng, Fuhai Subdistrict, Bao'an District, Shenzhen, Guangdong, China. The site and apparatus are constructed in conformance with the requirements of ANSI C63.4 and CISPR 16-1-1 other equivalent standards.

5.2 Test Instrument Used

| Conducted Emissions Test | | | | | |
|--------------------------|--------------|-----------------|----------------|--------------|--------------|
| Equipment | Manufacturer | Model# | Serial# | Last Cal. | Next Cal. |
| Receiver | R&S | ESR3 | 102075 | May 24, 2022 | May 23, 2023 |
| LISN | R&S | ENV216 | 101375 | May 24, 2022 | May 23, 2023 |
| Software | Frad | EZ-EMC | EMC-CON 3A1 | \ | \ |
| Attenuator | \ | 10dB DC-6GHz | 1650 | May 24, 2022 | May 23, 2023 |

| Radiated Emissions Test (966 Chamber#01) | | | | | |
|--|--------------|----------------------|------------|---------------|---------------|
| Equipment | Manufacturer | Model# | Serial# | Last Cal. | Next Cal. |
| 966 chamber | ChengYu | 966 Room | 966 | Jun. 06. 2020 | Jun. 05, 2023 |
| Receiver | R&S | ESRP | 101154 | May 24, 2022 | May 23, 2023 |
| Receiver | R&S | ESR3 | 102075 | May 24, 2022 | May 23, 2023 |
| Amplifier | SKET | LAPA_01G18 G-45dB | \ | May 24, 2022 | May 23, 2023 |
| Amplifier | Schwarzbeck | BBV9744 | 9744-0037 | May 24, 2022 | May 23, 2023 |
| TRILOG Broadband Antenna | schwarzbeck | VULB9163 | 942 | May 26, 2022 | May 25, 2023 |
| Horn Antenna | schwarzbeck | BBHA9120D | 1541 | May 26, 2022 | May 25, 2023 |
| Software | Frad | EZ-EMC | FA-03A2 RE | \ | \ |

| Electrostatic Discharge Test | | | | | |
|------------------------------|--------------|----------|----------|--------------|--------------|
| Equipment | Manufacturer | Model# | Serial# | Last Cal. | Next Cal. |
| ESD Tester | KIKUSUI | KES4201A | UH002321 | May 26, 2022 | May 25, 2023 |

| Continuous RF Electromagnetic Field Disturbances Test | | | | | |
|--|---------------------|---------------------|----------------|------------------|------------------|
| Equipment | Manufacturer | Model# | Serial# | Last Cal. | Next Cal. |
| Power meter | Keysight | E4419 | \ | May 24, 2022 | May 23, 2023 |
| Power sensor | Keysight | E9300A | \ | May 24, 2022 | May 23, 2023 |
| Power sensor | Keysight | E9300A | \ | May 24, 2022 | May 23, 2023 |
| Amplifier | SKET | HAP_801000 -250W | \ | May 24, 2022 | May 23, 2023 |
| Amplifier | SKET | HAP_0103-7 5W | \ | May 24, 2022 | May 23, 2023 |
| Amplifier | SKET | HAP_0306-5 0W | \ | May 24, 2022 | May 23, 2023 |
| Stacked double Log.-Per. Antenna | Schwarzbeck | STLP 9129 | \ | \ | \ |
| Field Probe | Narda | EP-601 | \ | Jun. 29, 2021 | Jun. 28, 2022 |
| Signal Generator | Agilent | N5181A | MY50143748 | May 24, 2022 | May 23, 2023 |
| Software | SKET | EMC-S | 1.2.0.18 | \ | \ |

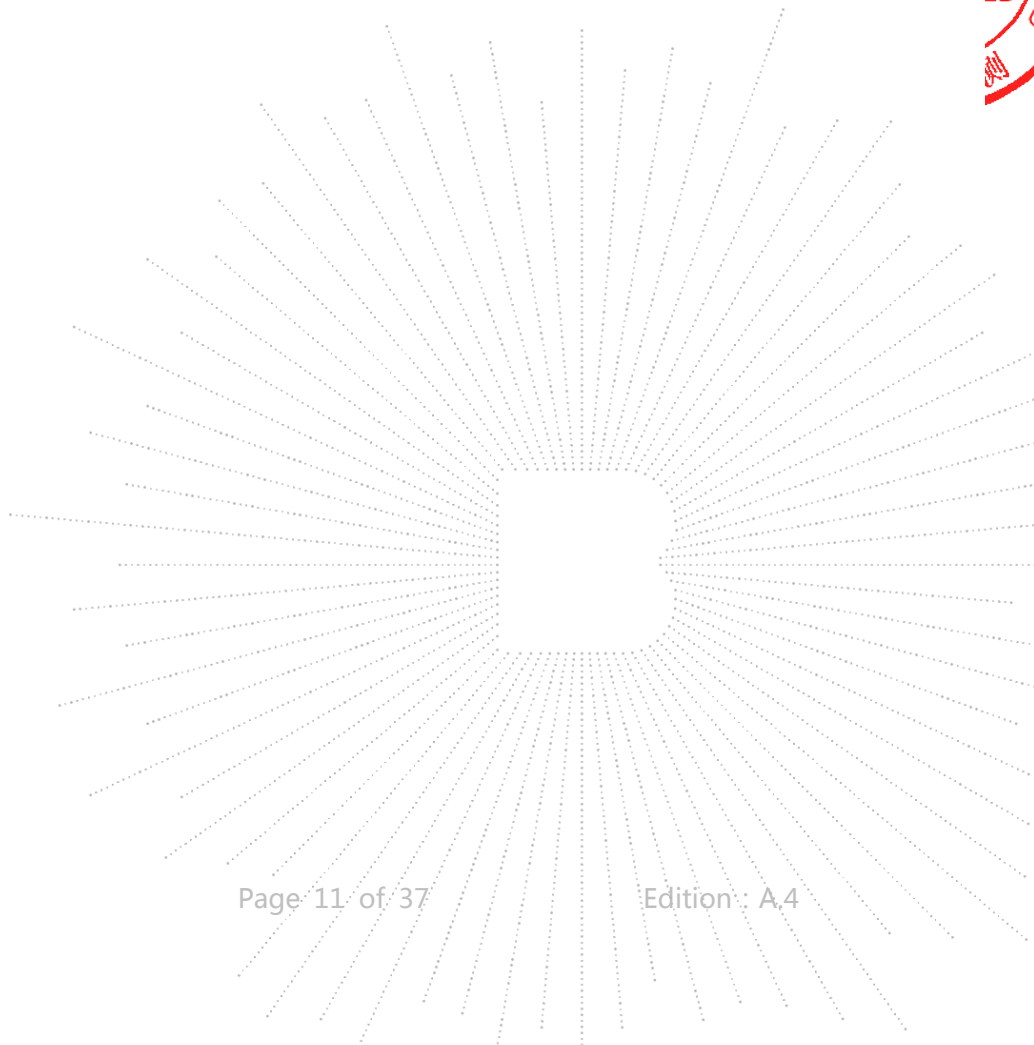

6. Conducted Emissions

6.1 Block Diagram Of Test Setup

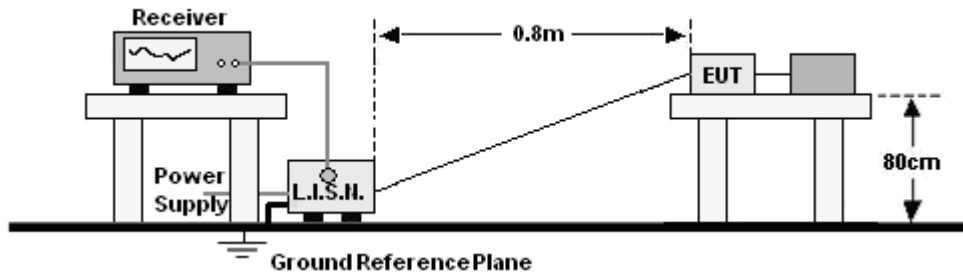

6.2 Limit

Limits for Conducted emissions at the mains ports of Class B MME

| Frequency range (MHz) | Limits dB(μ V) | |
|-----------------------|---------------------|-----------|
| | Quasi-peak | Average |
| 0,15 to 0,50 | 66 to 56* | 56 to 46* |
| 0,50 to 5 | 56 | 46 |
| 5 to 30 | 60 | 50 |

Notes:

- *Decreasing linearly with logarithm of frequency.
- The lower limit shall apply at the transition frequencies.

6.3 Test procedure

a. The Product was placed on a nonconductive table 0.8 m above the horizontal ground reference plane, and 0.4 m from the vertical ground reference plane, and connected to the main through Line Impedance Stability Network (L.I.S.N).

b. The RBW of the receiver was set at 9 kHz in 150 kHz ~ 30MHz with Peak and AVG detector in Max Hold mode. Run the receiver's pre-scan to record the maximum disturbance generated from Product in all power lines in the full band.

c. For each frequency whose maximum record was higher or close to limit, measure its QP and AVG values and record.

6.4 Test Result

| | | | |
|--------------|----------|--------------------|-----|
| Temperature: | 26 °C | Relative Humidity: | 54% |
| Pressure: | 101KPa | Phase : | L |
| Test Mode: | Charging | Remark: | N/A |

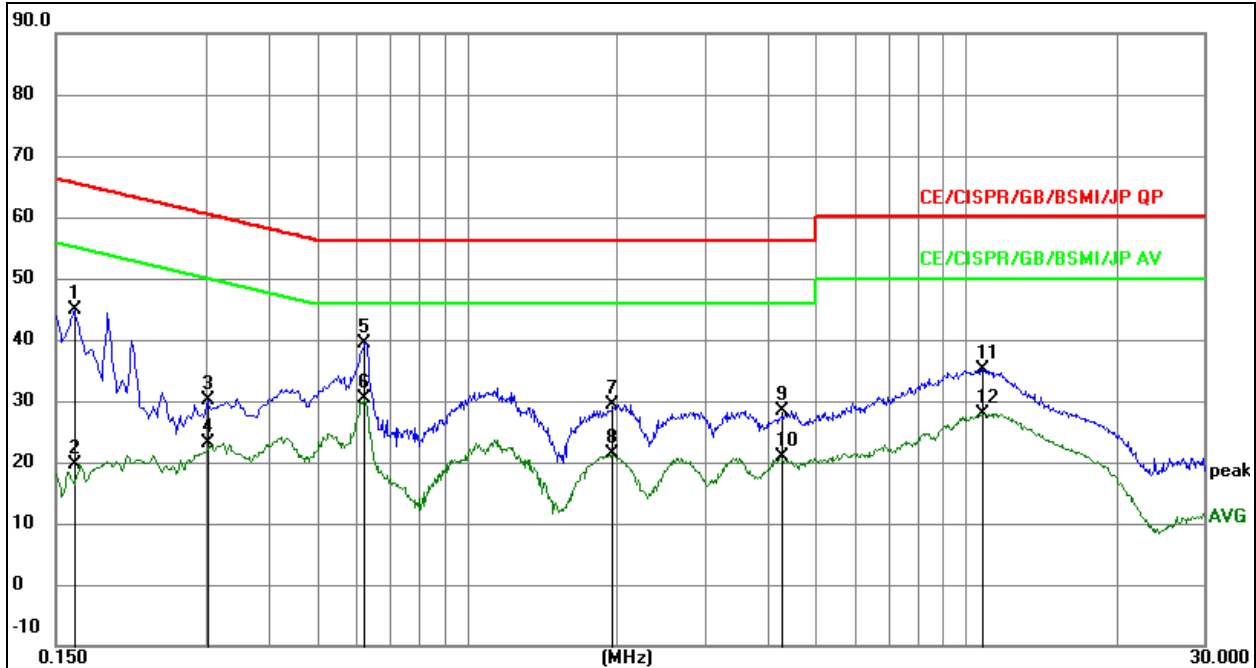

Remark:

1. All readings are Quasi-Peak and Average values.
2. Factor = Insertion Loss + Cable Loss.
3. Measurement = Reading Level + Correct Factor
4. Over = Measurement - Limit

| No. | Mk. | Freq. MHz | Reading Level | Correct Factor dB | Measure- ment dBuV | Limit dBuV | Over dB | Detector |
|-----|-----|--------------|------------------|-------------------------|--------------------------|---------------|------------|----------|
| 1 | | 0.1635 | 25.33 | 19.60 | 44.93 | 65.28 | -20.35 | QP |
| 2 | | 0.1635 | 0.07 | 19.60 | 19.67 | 55.28 | -35.61 | AVG |
| 3 | | 0.3030 | 10.44 | 19.61 | 30.05 | 60.16 | -30.11 | QP |
| 4 | | 0.3030 | 3.51 | 19.61 | 23.12 | 50.16 | -27.04 | AVG |
| 5 | | 0.6225 | 19.83 | 19.61 | 39.44 | 56.00 | -16.56 | QP |
| 6 | * | 0.6225 | 10.78 | 19.61 | 30.39 | 46.00 | -15.61 | AVG |
| 7 | | 1.9545 | 9.87 | 19.62 | 29.49 | 56.00 | -26.51 | QP |
| 8 | | 1.9545 | 1.65 | 19.62 | 21.27 | 46.00 | -24.73 | AVG |
| 9 | | 4.2630 | 8.76 | 19.68 | 28.44 | 56.00 | -27.56 | QP |
| 10 | | 4.2630 | 1.22 | 19.68 | 20.90 | 46.00 | -25.10 | AVG |
| 11 | | 10.7475 | 15.34 | 19.79 | 35.13 | 60.00 | -24.87 | QP |
| 12 | | 10.7475 | 8.17 | 19.79 | 27.96 | 50.00 | -22.04 | AVG |

SHENZHEN

| | | | |
|--------------|----------|--------------------|-----|
| Temperature: | 26 °C | Relative Humidity: | 54% |
| Pressure: | 101KPa | Phase : | N |
| Test Mode: | Charging | Remark: | N/A |

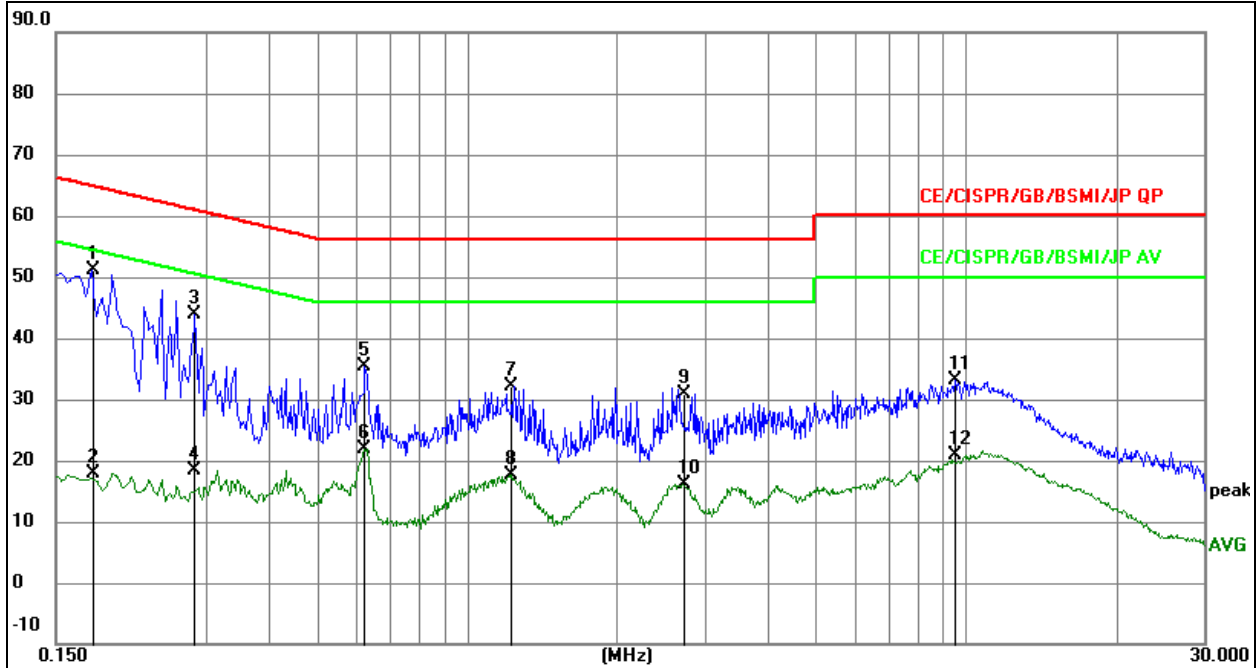
Remark:

1. All readings are Quasi-Peak and Average values.
2. Factor = Insertion Loss + Cable Loss.
3. Measurement = Reading Level + Correct Factor
4. Over = Measurement - Limit

| No. | Mk. | Freq. MHz | Reading Level | Correct Factor dB | Measure- ment dBuV | Limit dBuV | Over dB | Detector |
|-----|-----|--------------|------------------|-------------------------|--------------------------|---------------|------------|----------|
| 1 | * | 0.1768 | 31.49 | 19.60 | 51.09 | 64.63 | -13.54 | QP |
| 2 | | 0.1768 | -1.65 | 19.60 | 17.95 | 54.63 | -36.68 | AVG |
| 3 | | 0.2847 | 24.20 | 19.61 | 43.81 | 60.68 | -16.87 | QP |
| 4 | | 0.2847 | -1.35 | 19.61 | 18.26 | 50.68 | -32.42 | AVG |
| 5 | | 0.6238 | 15.65 | 19.61 | 35.26 | 56.00 | -20.74 | QP |
| 6 | | 0.6238 | 2.35 | 19.61 | 21.96 | 46.00 | -24.04 | AVG |
| 7 | | 1.2291 | 12.43 | 19.62 | 32.05 | 56.00 | -23.95 | QP |
| 8 | | 1.2291 | -1.97 | 19.62 | 17.65 | 46.00 | -28.35 | AVG |
| 9 | | 2.7068 | 11.15 | 19.64 | 30.79 | 56.00 | -25.21 | QP |
| 10 | | 2.7068 | -3.45 | 19.64 | 16.19 | 46.00 | -29.81 | AVG |
| 11 | | 9.5016 | 13.42 | 19.78 | 33.20 | 60.00 | -26.80 | QP |
| 12 | | 9.5016 | 1.15 | 19.78 | 20.93 | 50.00 | -29.07 | AVG |

7. Radiated Emissions Test

7.1 Block Diagram Of Test Setup

30MHz ~ 1GHz:

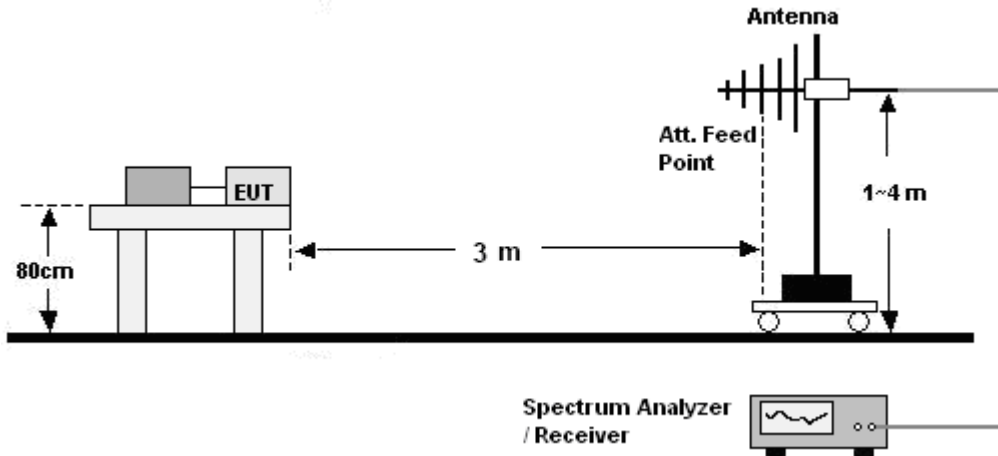

Above 1GHz:

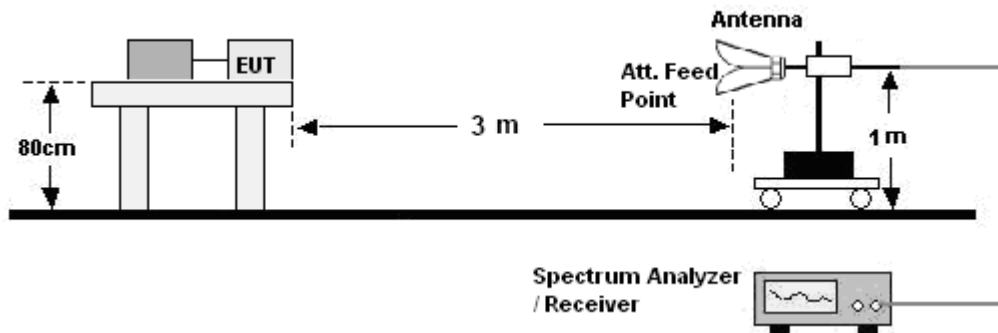

7.2 Limits

Limits for radiated disturbance of Class B MME

| Frequency (MHz) | Quasi-peak limits at 3m Db(Mv/m) | |
|-----------------|----------------------------------|------|
| 30-230 | 40 | |
| 230-1000 | 47 | |
| Frequency (GHz) | limit above 1G at 3m Db(Mv/m) | |
| | Average | peak |
| 1-3 | 50 | 70 |
| 3-6 | 54 | 74 |

Note: The lower limit shall apply at the transition frequencies.

7.3 Test Procedure

30MHz ~ 1GHz:

- a. The Product was placed on the nonconductive turntable 0.8 above the ground in a semi anechoic chamber.
- b. Set the spectrum analyzer/receiver in Peak detector, Max Hold mode, and 120 kHz RBW. Record the maximum field strength of all the pre-scan process in the full band when the antenna is varied between 1~4 m in both horizontal and vertical, and the turntable is rotated from 0 to 360 degrees.
- c. For each frequency whose maximum record was higher or close to limit, measure its QP value: vary the antenna's height and rotate the turntable from 0 to 360 degrees to find the height and degree where Product radiated the maximum emission, then set the test frequency analyzer/receiver to QP Detector and specified bandwidth with Maximum Hold Mode, and record the maximum value.

Above 1GHz:

- a. The Product was placed on the non-conductive turntable 0.8 m above the ground in a full anechoic chamber..
- b. Set the spectrum analyzer/receiver in Peak detector, Max Hold mode, and 1MHz RBW. Record the maximum field strength of all the pre-scan process in the full band when the antenna is varied in both horizontal and vertical, and the turntable is rotated from 0 to 360 degrees.
- c. For each frequency whose maximum record was higher or close to limit, measure its AV value: rotate the turntable from 0 to 360 degrees to find the degree where Product radiated the maximum emission, then set the test frequency analyzer/receiver to AV value and specified bandwidth with Maximum Hold Mode, and record the maximum value.

Above 1GHz

The amplitude of spurious emissions which are attenuated by more than 20dB below the permissible value has no need to be reported.

7.4 Test Results

| | | | |
|--------------|----------------|--------------------|------------|
| Temperature: | 26 °C | Relative Humidity: | 54% |
| Pressure: | 101KPa | Phase : | Horizontal |
| Test Mode: | The worst data | Remark: | N/A |

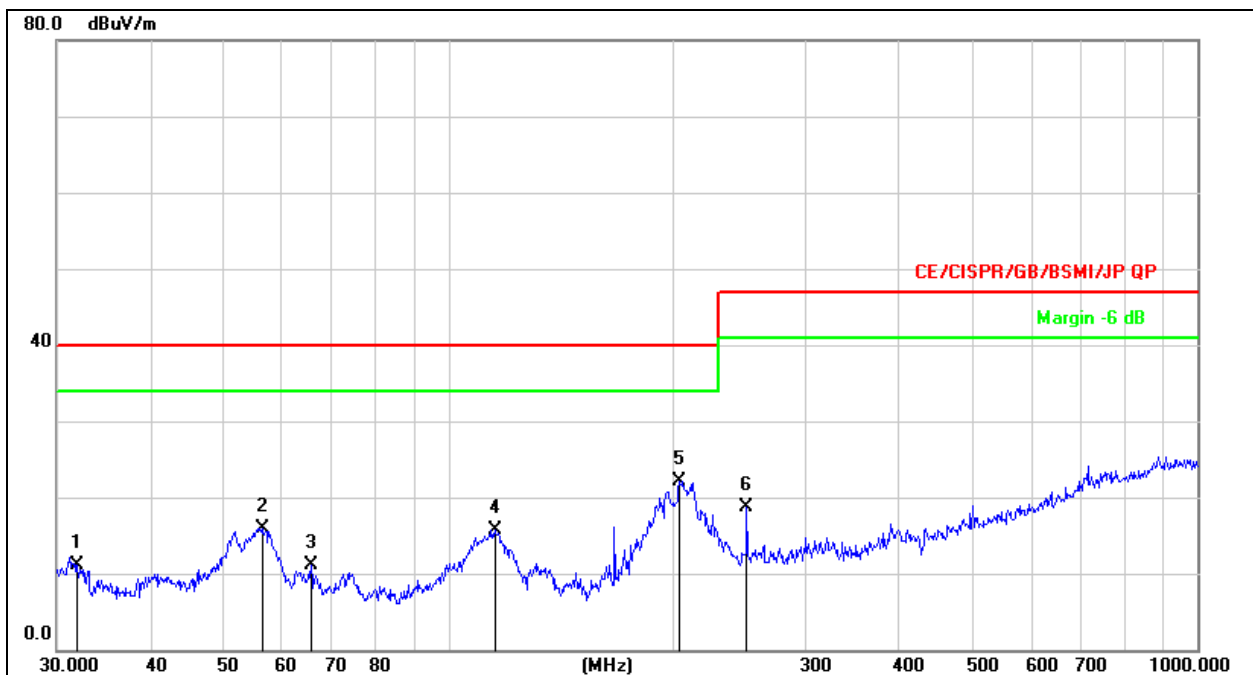

Remark:

- Factor = Antenna Factor + Cable Loss – Pre-amplifier.
- Measurement = Reading Level + Correct Factor
- Over = Measurement - Limit

| No. | Mk. | Freq. | Reading Level | Correct Factor | Measurement | Limit | Over | Detector |
|-----|-----|----------|---------------|----------------|-------------|-------|--------|----------|
| | | MHz | dBuV | dB | dBuV/m | dB/m | dB | |
| 1 | | 31.9546 | 29.33 | -18.15 | 11.18 | 40.00 | -28.82 | QP |
| 2 | | 56.3948 | 31.76 | -15.79 | 15.97 | 40.00 | -24.03 | QP |
| 3 | | 65.5727 | 28.55 | -17.53 | 11.02 | 40.00 | -28.98 | QP |
| 4 | | 115.3205 | 32.93 | -17.16 | 15.77 | 40.00 | -24.23 | QP |
| 5 | * | 203.5228 | 37.50 | -15.39 | 22.11 | 40.00 | -17.89 | QP |
| 6 | | 250.3012 | 33.41 | -14.64 | 18.77 | 47.00 | -28.23 | QP |

| | | | |
|--------------|----------------|--------------------|----------|
| Temperature: | 26 °C | Relative Humidity: | 54% |
| Pressure: | 101KPa | Phase : | Vertical |
| Test Mode: | The worst data | Remark: | N/A |

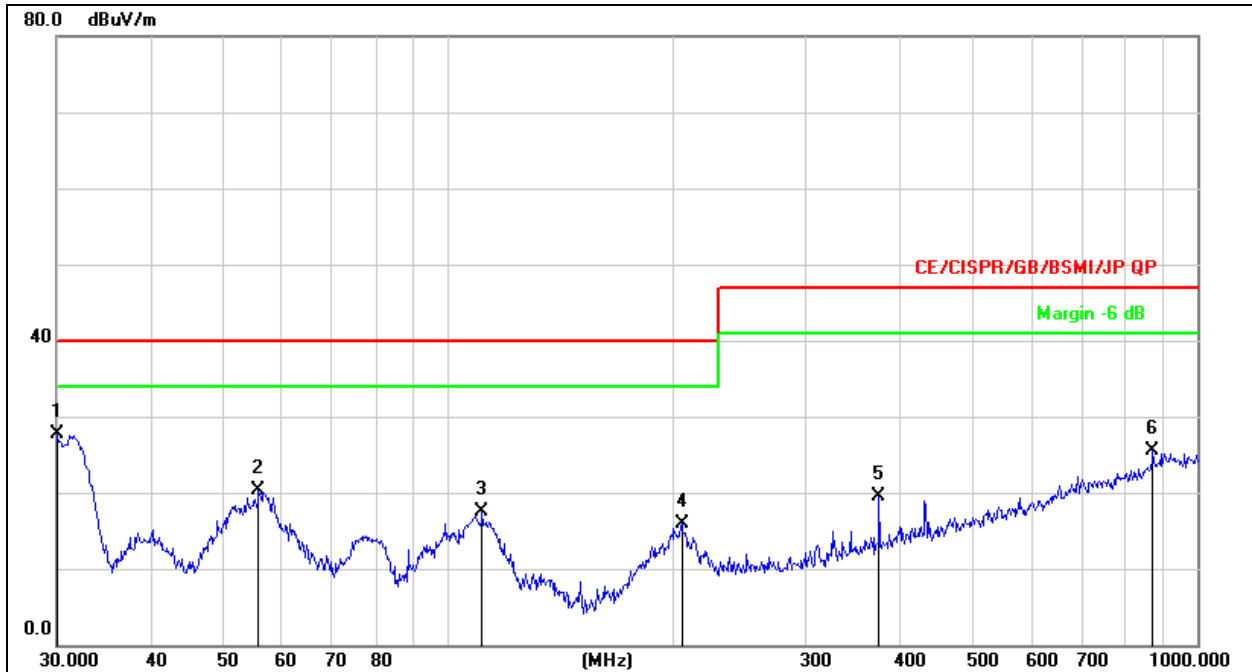

Remark:
 1. Factor = Antenna Factor + Cable Loss – Pre-amplifier.
 2. Measurement = Reading Level + Correct Factor
 3. Over = Measurement - Limit

| No. | Mk. | Freq. MHz | Reading Level dBuV | Correct Factor dB | Measure- ment dBuV/m | Limit dB/m | Over dB | Detector |
|-----|-----|--------------|--------------------------|-------------------------|----------------------------|---------------|------------|----------|
| 1 | * | 30.0000 | 46.16 | -18.45 | 27.71 | 40.00 | -12.29 | QP |
| 2 | | 55.8047 | 35.98 | -15.76 | 20.22 | 40.00 | -19.78 | QP |
| 3 | | 110.9571 | 34.31 | -16.87 | 17.44 | 40.00 | -22.56 | QP |
| 4 | | 204.9551 | 31.29 | -15.37 | 15.92 | 40.00 | -24.08 | QP |
| 5 | | 375.9385 | 31.01 | -11.55 | 19.46 | 47.00 | -27.54 | QP |
| 6 | | 872.1832 | 25.72 | -0.24 | 25.48 | 47.00 | -21.52 | QP |

8. Harmonic Current Emission(H)

8.1 Block Diagram of Test Setup

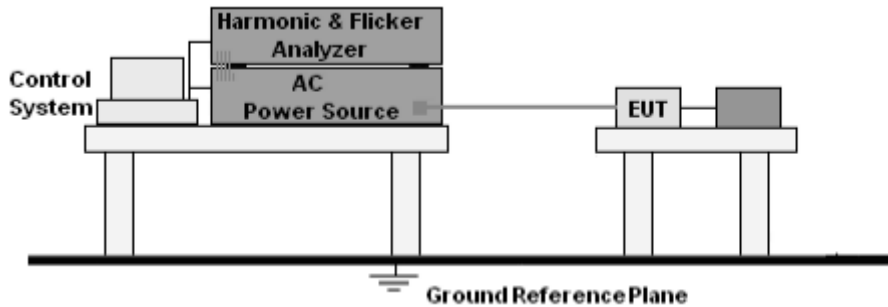

8.2 Limit

EN IEC 61000-3-2:2019+A1:2021 Clause 7.

8.3 Test Procedure

- The Product was placed on the top of a non-conductive table above the ground and operated to produce the maximum harmonic components under normal operating conditions for each successive harmonic component in turn.
- The correspondent test program of test instrument to measure the current harmonics emanated from Product was chosen. The measure time shall be not less than the time necessary for the Product to be exercised.

8.4 Test Results

The EUT is powered by the DC only, the test item is not applicable.

9. Voltage Fluctuations & Flicker(F)

9.1 Block Diagram of Test Setup

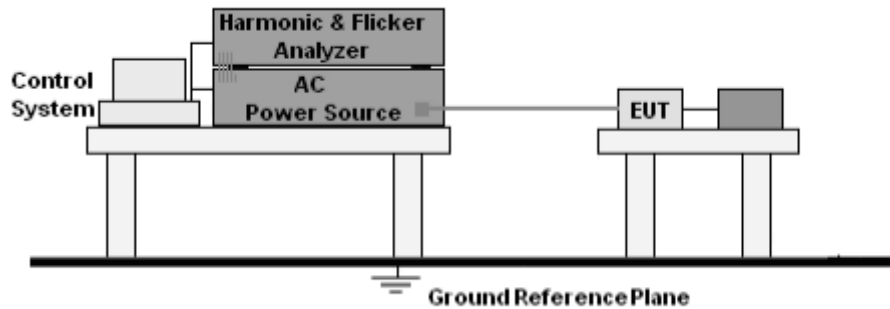

9.2 Limit

EN 61000-3-3:2013+A2:2021 Clause 5.

9.3 Test Procedure

- The Product was placed on the top of a non-conductive table above the ground and operated to produce the most unfavorable sequence of voltage changes under normal operating conditions.
- During the flick test, the measure time shall include that part of whole operation cycle in which the Product produce the most unfavorable sequence of voltage changes. The observation period for short-term flicker indicator is 10 minutes and the observation period for long-term flicker indicator is 2 hours.

9.4 Test Results

The EUT is powered by the DC only, the test item is not applicable.



10. Immunity Test Of General The Performance Criteria

According To EN 301489 -17standard, The General Performance Criteria As Following:

| Criteria | During test | After test (i.e. as a result of the application of the test) |
|---|--|--|
| A | Shall operate as intended. (see note). Shall be no loss of function. Shall be no unintentional transmissions. | Shall operate as intended. Shall be no degradation of performance. Shall be no loss of function. Shall be no loss of critical stored data. |
| B | May be loss of function. | Functions shall be self-recoverable. Shall operate as intended after recovering. Shall be no loss of critical stored data. |
| C | May be loss of function. | Functions shall be recoverable by the operator. Shall operate as intended after recovering. Shall be no loss of critical stored data. |
| <p>NOTE: Operate as intended during the test allows a level of degradation in accordance with Minimum performance level.</p> <p>Minimum performance level:</p> <p>For equipment that supports a PER or FER, the minimum performance level shall be a PER or FER less than or equal to 10 %.</p> <p>For equipment that does not support a PER or a FER, the minimum performance level shall be no loss of the wireless transmission function needed for the intended use of the equipment.</p> | | |

TC
3C
PPR
測

PERFORMANCE FOR TT

The performance criteria B shall apply, except for voltage dips of 100 ms and voltage interruptions of 5 000 ms duration, for which performance criteria C shall apply. Tests shall be repeated with the EUT in standby mode (if applicable) to ensure that unintentional transmission does not occur. In systems using acknowledgement signals, it is recognized that an acknowledgement (ACK) or not-acknowledgement (NACK) transmission may occur, and steps should be taken to ensure that any transmission resulting from the application of the test is correctly interpreted.

PERFORMANCE FOR TR

The performance criteria B shall apply, except for voltage dips of 100 ms and voltage interruptions of 5 000 ms duration for which performance criteria C shall apply. Where the EUT is a transceiver, under no circumstances, shall the transmitter operate unintentionally during the test. In systems using acknowledgement signals, it is recognized that an ACK or NACK transmission may occur, and steps should be taken to ensure that any transmission resulting from the application of the test is correctly interpreted.

PERFORMANCE FOR CT

The performance criteria A shall apply. Tests shall be repeated with the EUT in standby mode (if applicable) to ensure that unintentional transmission does not occur. In systems using acknowledgement signals, it is recognized that an Acknowledgement (ACK) or Not Acknowledgement (NACK) transmission may occur, and steps should be taken to ensure that any transmission resulting from the application of the test is correctly interpreted.

PERFORMANCE FOR CR

The performance criteria A shall apply. Where the EUT is a transceiver, under no circumstances, shall the transmitter operate unintentionally during the test. In systems using acknowledgement signals, it is recognized that an ACK or NACK transmission may occur, and steps should be taken to ensure that any transmission resulting from the application of the test is correctly interpreted.

11. Electrostatic Discharge (ESD)

11.1 Test Specification

| | | |
|----------------------------|---|-----------------------------------|
| Test Port | : | Enclosure port |
| Discharge Impedance | : | 330 ohm / 150 pF |
| Discharge Mode | : | Single Discharge |
| Discharge Period | : | one second between each discharge |

11.2 Block Diagram of Test Setup

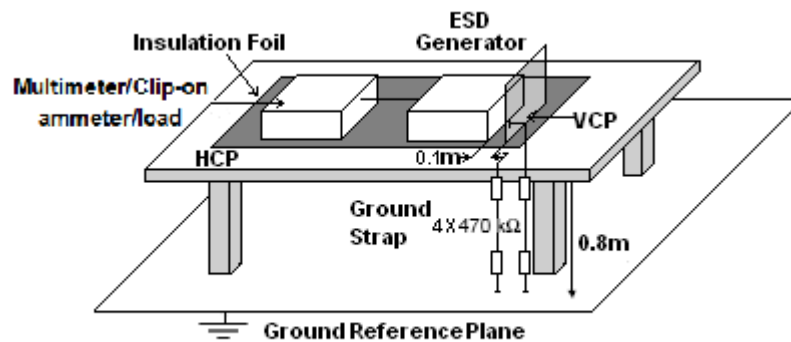

11.3 Test Procedure

- Electrostatic discharges were applied only to those points and surfaces of the Product that are accessible to users during normal operation.
- The test was performed with at least ten single discharges on the pre-selected points in the most sensitive polarity.
- The time interval between two successive single discharges was at least 1 second.
- The ESD generator was held perpendicularly to the surface to which the discharge was applied and the return cable was at least 0.2 meters from the Product.
- Contact discharges were applied to the non-insulating coating, with the pointed tip of the generator penetrating the coating and contacting the conducting substrate.
- Air discharges were applied with the round discharge tip of the discharge electrode approaching the Product as fast as possible (without causing mechanical damage) to touch the Product. After each discharge, the ESD generator was removed from the Product and re-triggered for a new single discharge. The test was repeated until all discharges were complete.

11.4 Test Results

| | | | |
|---------------|--------|--------------------|--------------------|
| Temperature : | 26 °C | Relative Humidity: | 54% |
| Pressure : | 101KPa | Test Mode: | Charging / BT Link |

| Mode | Air Discharge (Test result) | | | | | | | | Contact Discharge (Test result) | | | | | | | | Perform Criteria | Judgment |
|-----------------|-----------------------------|---|---|---|---|---|----|---|---------------------------------|---|---|---|---|---|---|---|------------------|----------|
| | 2 | | 4 | | 8 | | 15 | | 2 | | 4 | | 6 | | 8 | | | |
| Test level (kV) | | | | | | | | | | | | | | | | | | |
| Test Location | + | - | + | - | + | - | + | - | + | - | + | - | + | - | + | - | | |
| HCP | | | | | | | | | A | A | A | A | | | | | TT,TR | PASS |
| VCP | | | | | | | | | A | A | A | A | | | | | TT,TR | PASS |
| enclosure | A | A | A | A | A | A | | | A | A | A | A | | | | | TT,TR | PASS |
| Keys | A | A | A | A | A | A | | | | | | | | | | | TT,TR | PASS |

Note:

- 1) P/N denotes the Positive/Negative polarity of the output voltage.
- 2) Test condition:
 Direct / Indirect (HCP/VCP) discharges: Minimum 50 times (Positive/Negative) at each point. Air discharges: Minimum 10 times (Positive/Negative) at each point.
- 3) N/A - denotes test is not applicable in this test report
- 4) There was not any unintentional transmission in standby mode

CO., LTD

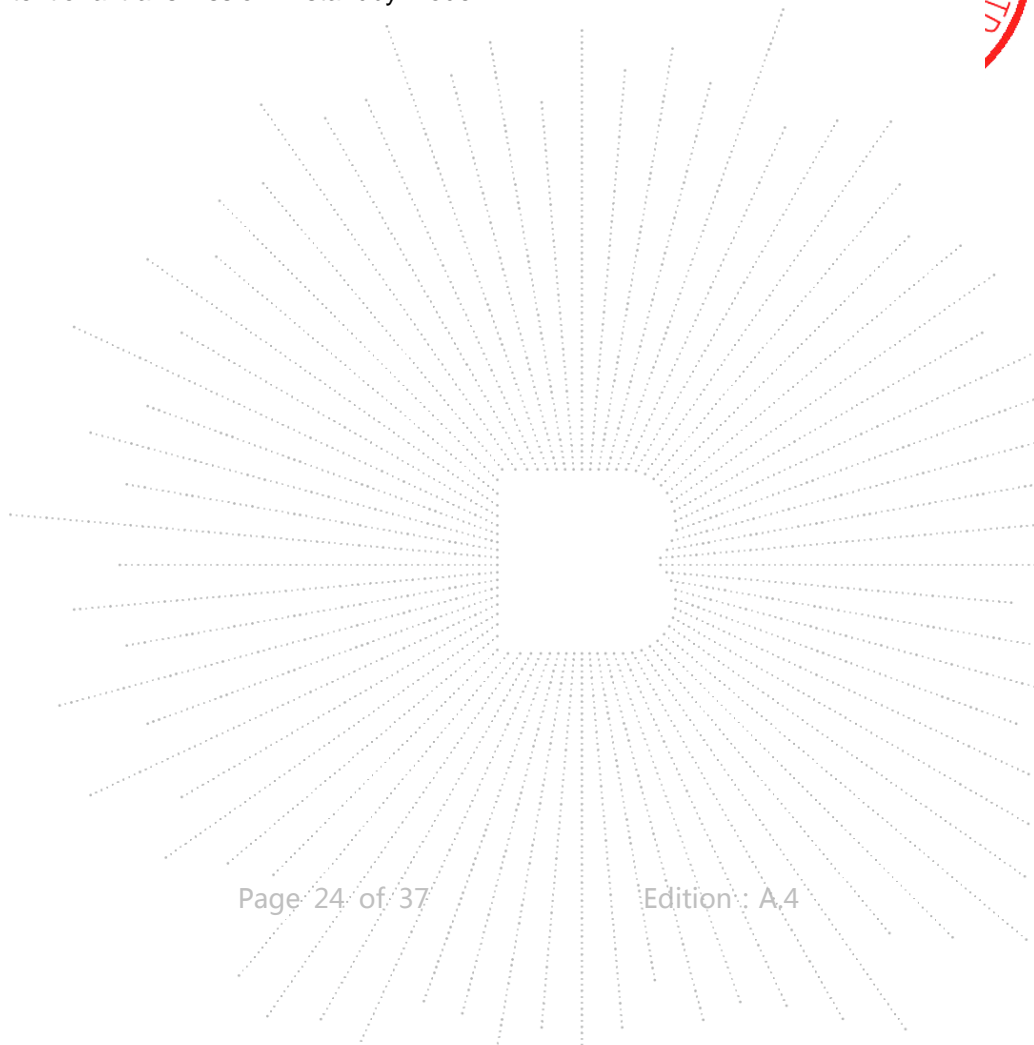

12. Continuous RF Electromagnetic Field Disturbances(RS)

12.1 Test Specification

| | | |
|---------------------|---|-----------------------|
| Test Port | : | Enclosure port |
| Step Size | : | 1% |
| Modulation | : | 1kHz, 80% AM |
| Dwell Time | : | 1 second |
| Polarization | : | Horizontal & Vertical |

12.2 Block Diagram of Test Setup

Below 1GHz:

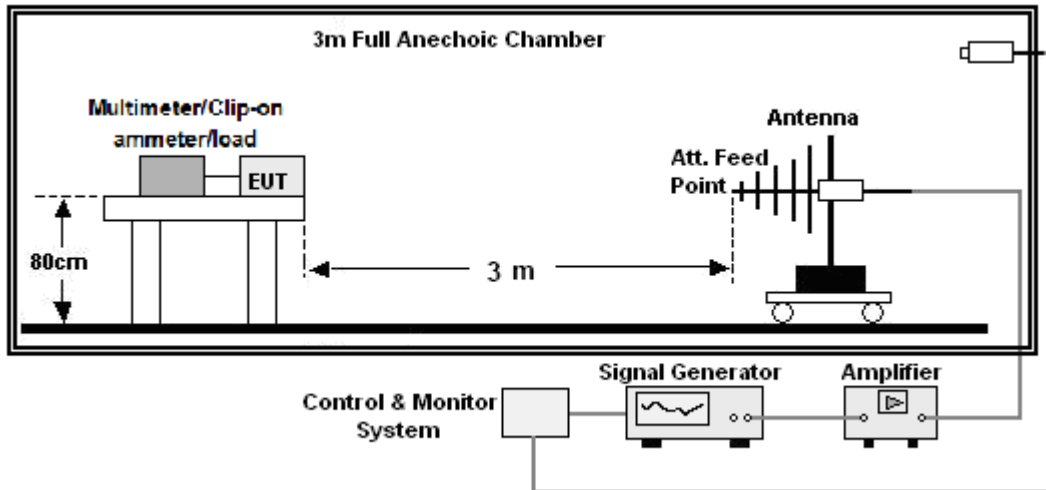

Above 1GHz:

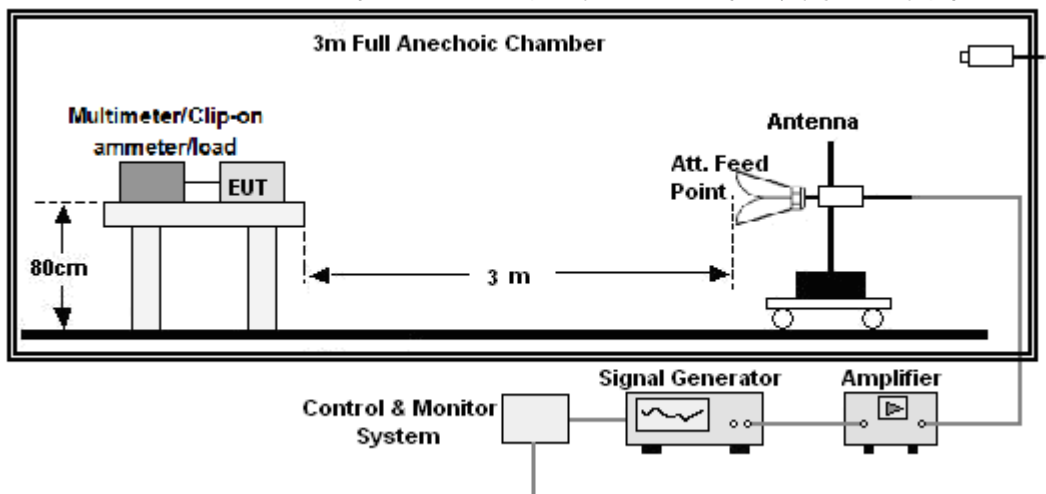

12.3 Test Procedure

- a. The testing was performed in a fully-anechoic chamber. The transmit antenna was located at a distance of 3 meters from the Product.
- b. The frequency range is swept from 80MHz to 6000MHz, with the signal 80% amplitude modulated with a 1 kHz sine wave, and the step size was 1%.
- c. The dwell time at each frequency shall not be less than the time necessary for the EUT to be exercised and to be able to respond, but should not exceed 5 s at each of the frequencies during the scan.
- d. The test was performed with the Product exposed to both vertically and horizontally polarized fields on each of the four sides.
- e. For Broadcast reception function: Group 2 not apply in this test.

12.4 Test Results

| | | | |
|---------------|--------|--------------------|--------------------|
| Temperature : | 26 °C | Relative Humidity: | 54% |
| Pressure : | 101KPa | Test Mode: | Charging / BT Link |

| Frequency Range (MHz) | RF Field Position | R.F. Field Strength | Azimuth | Perform Criteria | Test Result | Judgment |
|-----------------------|-------------------|--|---------|------------------|-------------|----------|
| 80~6000 | H / V | 3 V/m (rms) AM Modulated 1000Hz, 80% | Front | CT,CR | A | PASS |
| | | | Rear | | | |
| | | | Left | | | |
| | | | Right | | | |

Note:

- 1) P/N denotes the Positive/Negative polarity of the output voltage.
- 2) N/A - denotes test is not applicable in this test report.
- 3) There was no change operated with initial operating during the test.
- 4) There was not any unintentional transmission in standby mode



13. Electrical Fast Transients/Burst (EFT)

13.1 Test Specification

| | | |
|---------------------------|---|--------------------------|
| Test Port | : | input AC / DC power port |
| Impulse Frequency | : | 5 kHz |
| Impulse Wave-shape | : | 5/50 ns |
| Burst Duration | : | 15 ms |
| Burst Period | : | 300 ms |
| Test Duration | : | 2 minutes per polarity |

13.2 Block Diagram of EUT Test Setup

For input AC / DC power port:

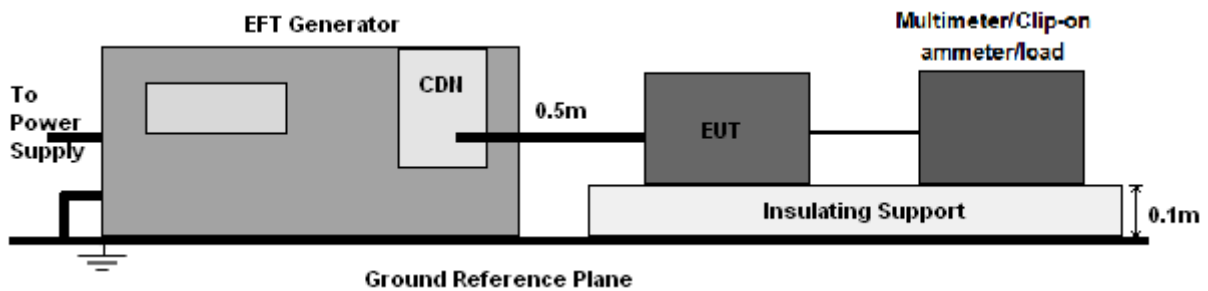

13.3 Test Procedure

- The Product and support units were located on a non-conductive table above ground reference plane.
- A 0.5m-long power cord was attached to Product during the test.

13.4 Test Results

The EUT is powered by the DC only, the test item is not applicable.

14. Surges Immunity Test

14.1 Test Specification

| | |
|------------------------------|---|
| Test Port | : input AC / DC power port |
| Wave-Shape | : Open Circuit Voltage - 1.2 / 50 us Short Circuit Current - 8 / 20 us |
| Pulse Repetition Rate | : 1 pulse / min. |
| Phase Angle | : 0° / 90° / 180° / 270° |
| Test Events | : 5 pulses (positive & negative) for each polarity |

14.2 Block Diagram of EUT Test Setup

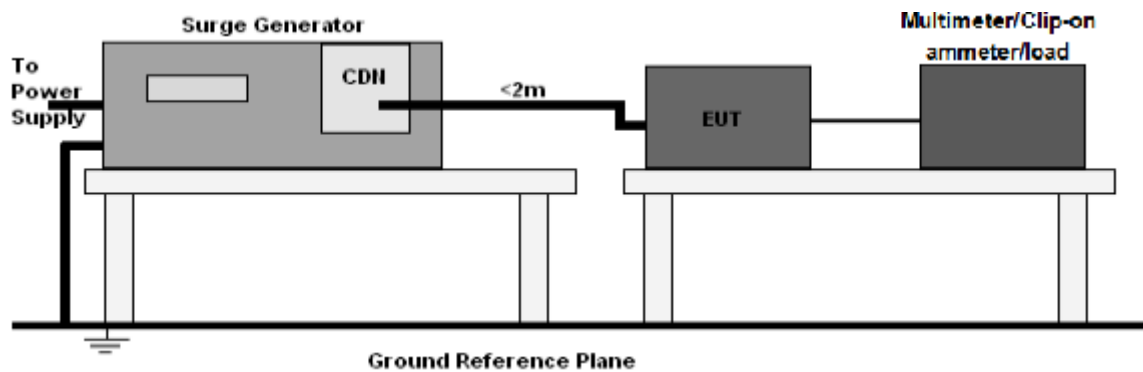

14.3 Test Procedure

- The surge is to be applied to the Product power supply terminals via the capacitive coupling network. Decoupling networks are required in order to avoid possible adverse effects on equipment not under test that may be powered by the same lines, and to provide sufficient decoupling impedance to the surge wave.
- The power cord between the Product and the coupling/decoupling networks shall be 2 meters in length (or shorter). Interconnection line between the Product and the coupling/decoupling networks shall be 2 meters in length (or shorter).

14.4 Test Result

The EUT is powered by the DC only, the test item is not applicable.

15. Continuous Induced RF Disturbances (CS)

15.1 Test Specification

| | | |
|-------------------|---|--------------------------|
| Test Port | : | input AC / DC power port |
| Step Size | : | 1% |
| Modulation | : | 1kHz, 80% AM |
| Dwell Time | : | 1 second |

15.2 Block Diagram of EUT Test Setup

For input AC / DC power port:

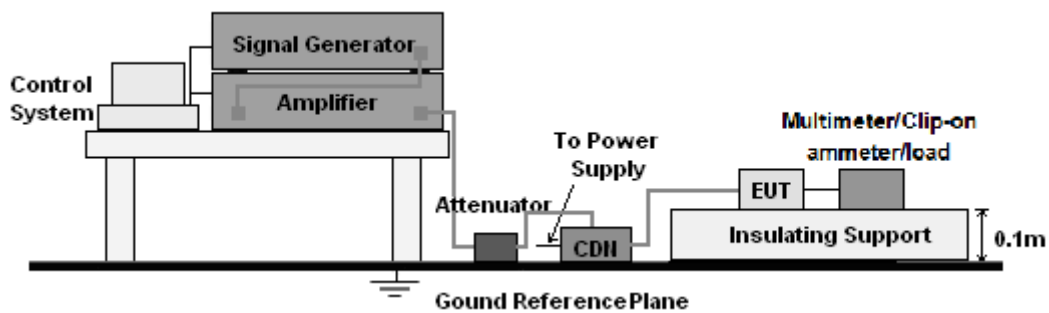

15.3 Test Procedure

For input AC/ DC power port:

- The Product and support units were located at a ground reference plane with the interposition of a 0.1 m thickness insulating support and the CDN was located on GRP directly.
- The frequency range is swept from 150 kHz to 10MHz, 10MHz to 30MHz, 30MHz to 80MHz with the signal 80% amplitude modulated with a 1 kHz sine wave, and the step size was 1% of fundamental.
- The dwell time at each frequency shall be not less than the time necessary for the Product to be able to respond.

15.4 Test Result

The EUT is powered by the DC only, the test item is not applicable.

16. Voltage Dips And Interruptions (DIPS)

16.1 Test Specification

| | |
|--------------------|-----------------------|
| Test Port | : input AC power port |
| Phase Angle | : 0°, 180° |
| Test cycle | : 3 times |

16.2 Block Diagram of EUT Test Setup

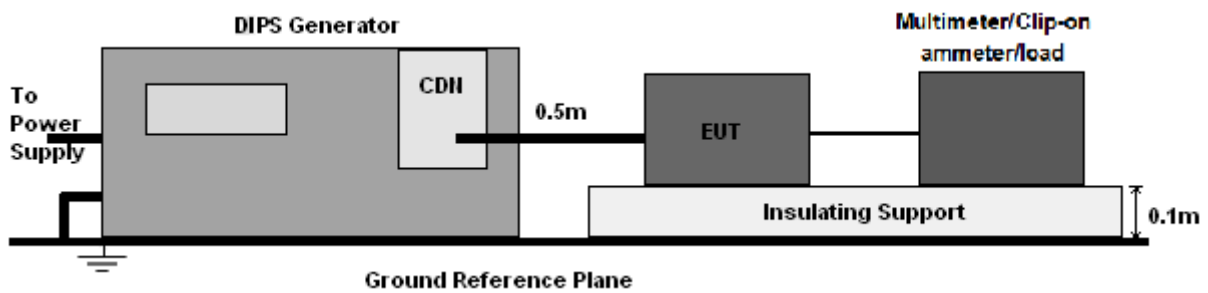

16.3 Test Procedure

- The Product and support units were located on a non-conductive table above ground floor.
- Set the parameter of tests and then perform the test software of test simulator.
- Conditions changes to occur at 0 degree crossover point of the voltage waveform.

16.4 Test Result

The EUT is powered by the DC only, the test item is not applicable.

17. EUT Photographs

EUT Photo 1

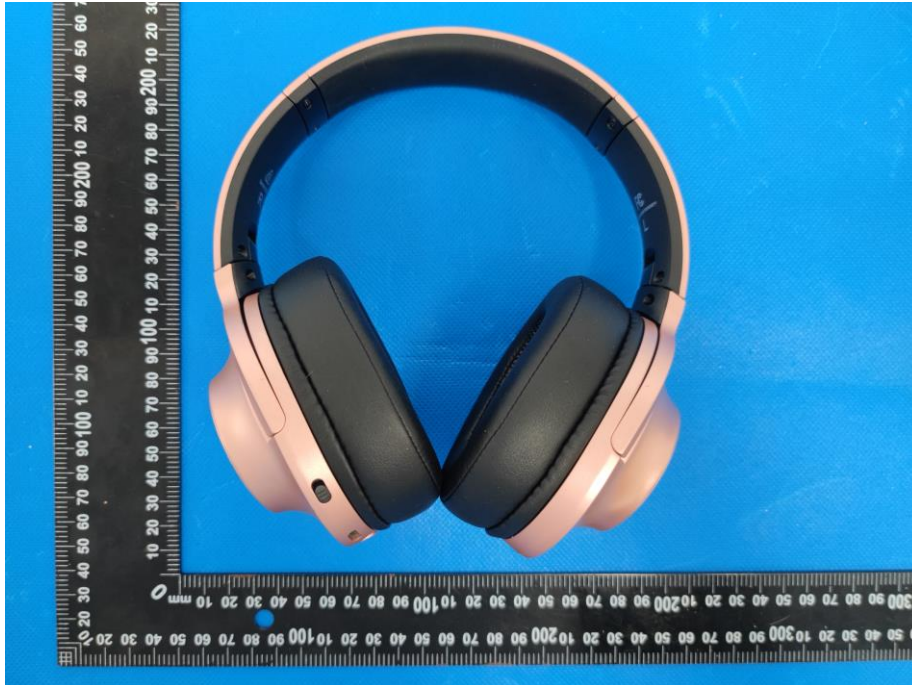

EUT Photo 2

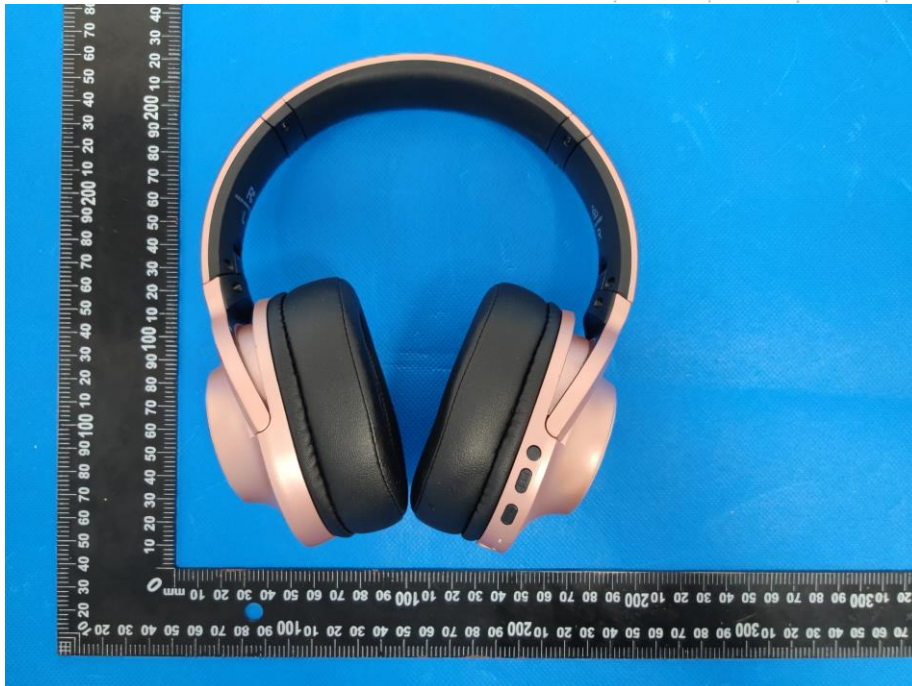

EUT Photo 3



EUT Photo 4



EUT Photo 5

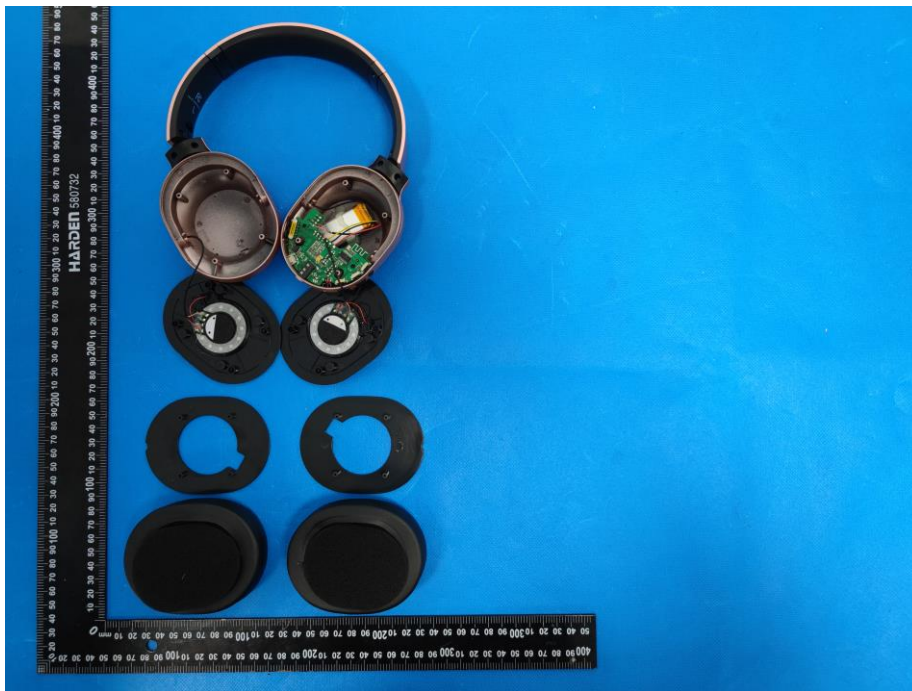

EUT Photo 6

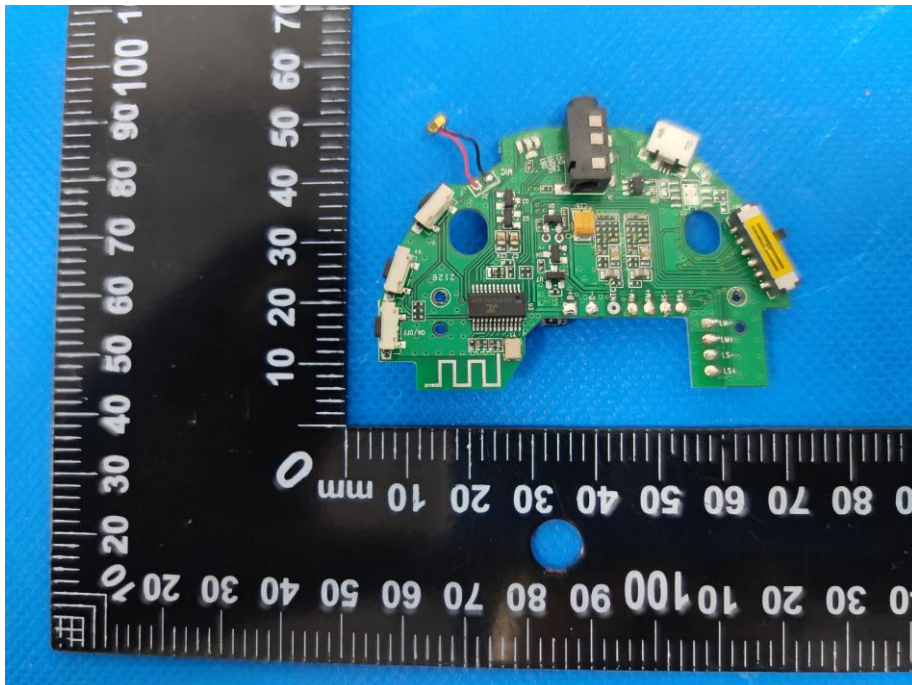

BCTC
BC
APP
停

EUT Photo 7

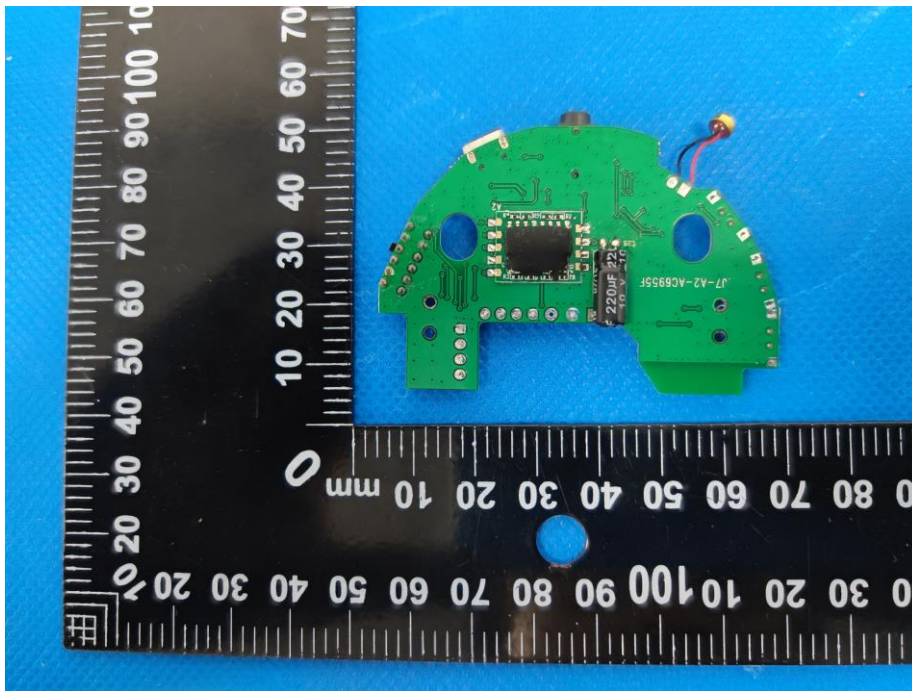

EUT Photo 8

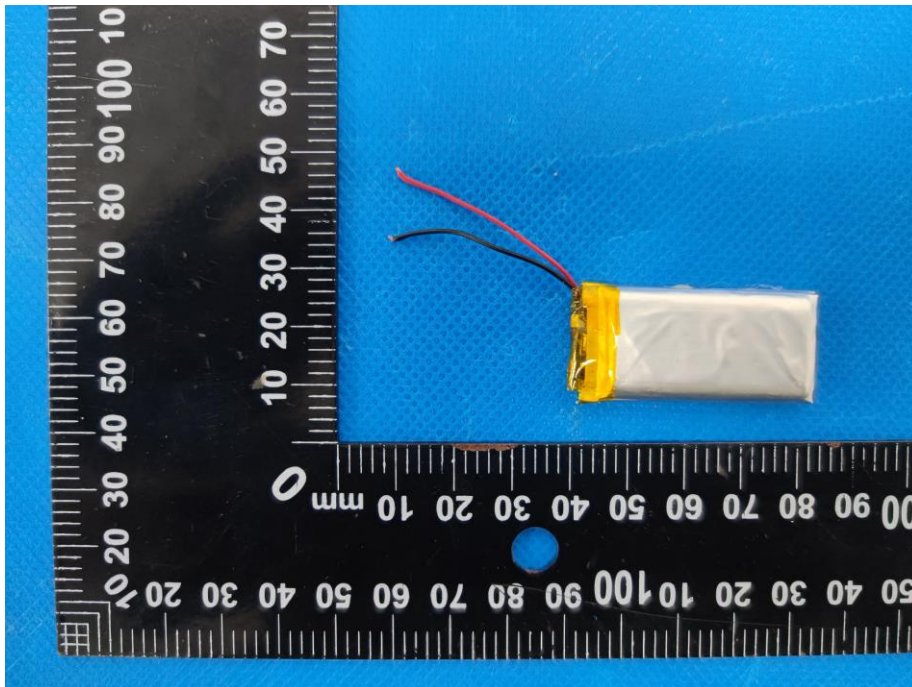

CT
PROC
則

18. EUT Test Setup Photographs

Conducted emissions

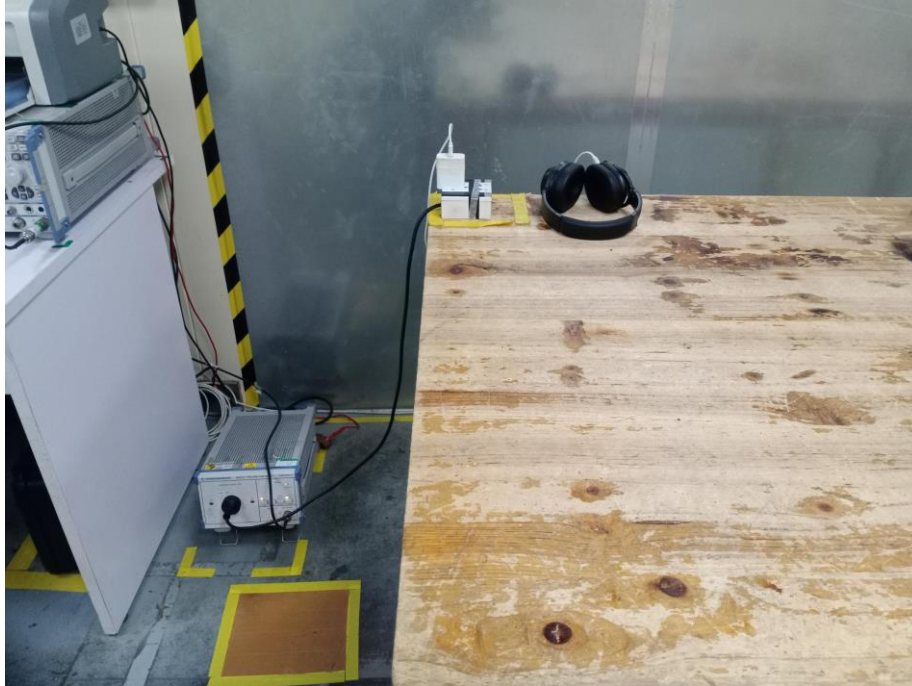

Radiated emissions



ESD



RS

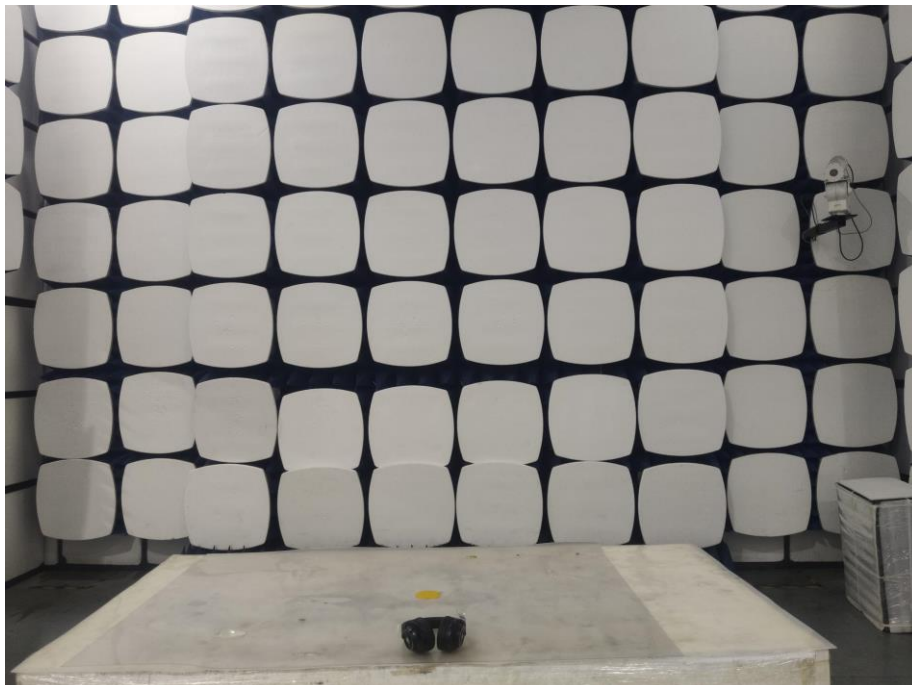

STATEMENT

- 1.The equipment lists are traceable to the national reference standards.
- 2.The test report can not be partially copied unless prior written approval is issued from our lab.
- 3.The test report is invalid without stamp of laboratory.
- 4.The test report is invalid without signature of person(s) testing and authorizing.
- 5.The test process and test result is only related to the Unit Under Test.
- 6.The quality system of our laboratory is in accordance with ISO/IEC17025.
- 7.If there is any objection to report, the client should inform issuing laboratory within 15 days from the date of receiving test report.

Address:

1-2/F., Building B, Pengzhou Industrial Park, No.158, Fuyuan 1st Road, Zhancheng, Fuhai Subdistrict, Bao'an District, Shenzhen, Guangdong, China

TEL : 400-788-9558

P.C.: 518103

FAX : 0755-33229357

Website : <http://www.chnbctc.com>

E-Mail : bctc@bctc-lab.com.cn

***** END *****

CO., LTD.