

# EMC TEST REPORT

**Sample:** Wireless Headset

**Trade Name:** N/A

**Main Model:** X10S

**Additional Model:** JH-TWS30

**Report No.:** UNIA22080915ER-01

## Prepared for

SHENZHEN JIUHU TECHNOLOGY CO., LTD.

Floor 4, Building E, No.10 HuanGuan South Road,  
GuanLan JunLong Community, ShenZhen

## Prepared by

Shenzhen United Testing Technology Co., Ltd.

2F, Annex Bldg, Jiahuangyuan Tech Park, #365 Baotian 1 Rd, Tiegang  
Community, Xixiang Str, Bao'an District, Shenzhen, China

## TEST RESULT CERTIFICATION

**Applicant** ..... : SHENZHEN JIUHU TECHNOLOGY CO., LTD.  
Address ..... : Floor 4, Building E, No.10 HuanGuan South Road, GuanLan JunLong Community, ShenZhen

**Manufacturer** ..... : SHENZHEN JIUHU TECHNOLOGY CO., LTD.  
Address ..... : Floor 4, Building E, No.10 HuanGuan South Road, GuanLan JunLong Community, ShenZhen

**Product description**

Product ..... : Wireless Headset  
Trade Name ..... : N/A  
Model Name ..... : X10S, JH-TWS30

**Standards** ..... : ETSI EN 301 489-1 V2.2.3 (2019-11)  
ETSI EN 301 489-17 V3.2.4 (2020-09)

This equipment under test described above has been tested by Shenzhen United Testing Technology Co., Ltd., and the test results show that the EUT is in compliance with the 2014/53/EU RE Directive Art.3.2 requirements.

### Date of Test

Date (s) of performance of tests ..... : Aug. 09, 2022 ~ Aug. 20, 2022  
Date of Issue ..... : Oct. 10, 2022  
Test Result ..... : Pass

Prepared by:

**kahn.yang**

Kahn Yang/Editor



Reviewer:

Kelly Cheng/Supervisor



Approved & Authorized Signer:

Liuze/Manager

**Table of Contents**

**Page**

<b>1 TEST SUMMARY .....</b>	<b>6</b>
1.1 TEST RESULTS .....	6
1.2 TEST LOCATION.....	7
1.3 MEASUREMENT UNCERTAINTY .....	7
1.4 ENVIRONMENTAL CONDITIONS .....	7
<b>2 GENERAL INFORMATION.....</b>	<b>8</b>
2.1 GENERAL DESCRIPTION OF EUT .....	8
2.2 DESCRIPTION OF THE TEST MODES .....	9
2.3 DESCRIPTION OF TEST SETUP.....	9
2.4 DESCRIPTION TEST PERIPHERAL AND EUT PERIPHERAL.....	9
2.5 MEASUREMENT INSTRUMENTS LIST .....	10
<b>3 CONDUCTED EMISSIONS MEASUREMENT .....</b>	<b>12</b>
3.1 CONDUCTED EMISSION LIMIT .....	12
3.2 TEST SETUP .....	12
3.3 TEST PROCEDURE .....	13
3.4 TEST RESULT .....	13
<b>4 RADIATED EMISSIONSMEASUREMENT.....</b>	<b>16</b>
4.1 RADIATION EMISSION LIMIT .....	16
4.2 TEST SETUP .....	16
4.3 TEST PROCEDURE .....	17
4.4 TEST RESULT .....	17
<b>5 HARMONICS CURRENT .....</b>	<b>22</b>
5.1 HARMONICS CURRENT LIMIT .....	22
5.2 TEST SETUP .....	23
5.3 TEST PROCEDURE .....	23
5.4 TEST RESULT .....	23
<b>6 VOLTAGE FLUCTUATION AND FLICKERS.....</b>	<b>24</b>
6.1 VOLTAGE FLUCTUATION AND FLICKERS LIMIT.....	24
6.2 TEST SETUP .....	24
6.3 TEST PROCEDURE .....	24
6.4 TEST RESULT .....	25

**Table of Contents**

**Page**

<b>7 EMC IMMUNITY TEST .....</b>	<b>26</b>
7.1 DESCRIPTION OF PERFORMANCE CRITERIA.....	26
7.2 GENERAL PERFORMANCE CRITERIA.....	26
7.3 PERFORMANCE TABLE .....	27
<b>8 ELECTROSTATIC DISCHARGE IMMUNITY TEST (ESD).....</b>	<b>28</b>
8.1 TEST SPECIFICATION .....	28
8.2 TEST SETUP .....	28
8.3 TEST PROCEDURE .....	29
8.4 TEST RESULT .....	30
<b>9 RADIATED, RADIO-FREQUENCY, ELECTROMAGNETIC FIELD IMMUNITY TEST (RS) .....</b>	<b>31</b>
9.1 TEST SPECIFICATION .....	31
9.2 TEST SETUP .....	31
9.3 TEST PROCEDURE .....	32
9.4 TEST RESULT .....	32
<b>10 ELECTRICAL FAST TRANSIENT IMMUNITY TEST (EFT).....</b>	<b>33</b>
10.1 TEST SPECIFICATION .....	33
10.2 TEST SETUP .....	33
10.3 TEST PROCEDURE .....	35
10.4 TEST RESULT .....	35
<b>11 SURGE IMMUNITY TEST (SURGE).....</b>	<b>36</b>
11.1 TEST SPECIFICATION .....	36
11.2 TEST SETUP .....	36
11.3 TEST PROCEDURE .....	37
11.4 TEST RESULT .....	37
<b>12 CONDUCTED RADIO FREQUENCY DISTURBANCES IMMUNITY TEST (CS).....</b>	<b>38</b>
12.1 TEST SPECIFICATION .....	38
12.2 TEST SETUP .....	38
12.3 TEST PROCEDURE .....	39
12.4 TEST RESULT .....	39
<b>13 POWER FREQUENCY MAGNETIC FIELD IMMUNITY TEST (PFMF).....</b>	<b>40</b>
13.1 TEST SPECIFICATION .....	40
13.2 TEST SETUP .....	40

<b>Table of Contents</b>	<b>Page</b>
13.3 TEST PROCEDURE .....	41
13.4 TEST RESULT .....	41
<b>14 VOLTAGE INTERRUPTION/DIPS IMMUNITY TEST (DIPS).....</b>	<b>42</b>
14.1 TEST SPECIFICATION .....	42
14.2 TEST SETUP .....	42
14.3 TEST PROCEDURE .....	43
14.4 TEST RESULT .....	43
<b>15 PHOTO OF EUT .....</b>	<b>44</b>
<b>16 PHOTO OF TEST .....</b>	<b>50</b>



# 1 TEST SUMMARY

## 1.1 TEST RESULTS

Test procedures according to the technical standards:

ETSI EN 301 489-1 V2.2.3 (2019-11)

ETSI EN 301 489-17 V3.2.4 (2020-09)

EMC Emission				
Standard	Test Item	Class	Result	Remark
EN 55032:2015+A11:2020	Conducted Emission On AC Mains Power Ports 150kHz to 30MHz	Class B	PASS	--
	Conducted Emission On Telecom Port 150kHz to 30MHz	Class B	N/A	--
	Radiated Emission 30MHz to 1000MHz	Class B	PASS	--
	Radiated Emission 1GHz to 6GHz	Class B	PASS	NOTE (1)
EN IEC 61000-3-2:2019 +A1:2021	Harmonic Current Emission	--	N/A	NOTE (2)
EN 61000-3-3:2013 +A2:2021+AC:2022-01	Voltage Fluctuations & Flicker	--	PASS	--
EMC Immunity				
Section EN 55035:2017+A11:2020	Test Item	Performance Criteria	Result	Remark
EN 61000-4-2:2009	Electrostatic Discharge	B	PASS	--
EN IEC 61000-4-3:2020	RF Electromagnetic Field	A	PASS	--
EN 61000-4-4:2012	Fast Transients	B	PASS	--
EN 61000-4-5:2014 +A1:2017	Surges	B	PASS	--
EN 61000-4-6:2014 +AC:2015	Injected Current	A	PASS	--
EN 61000-4-8:2010	Power Frequency Magnetic Field	A	PASS	--
EN IEC 61000-4-11:2020 +AC:2020-06	Volt. Interruptions Volt. Dips	B / C / C	PASS	NOTE (3)

Note:

(1) If the highest frequency of the internal sources of the EUT is less than 108 MHz, the measurement shall only be made up to 1 GHz.

If the highest frequency of the internal sources of the EUT is between 108 MHz and 500 MHz, the measurement shall only be made up to 2 GHz.

If the highest frequency of the internal sources of the EUT is between 500 MHz and 1GHz, the measurement shall only be made up to 5 GHz.

If the highest frequency of the internal sources of the EUT is above 1 GHz, the measurement shall be made up to 5 times of the highest frequency or 6 GHz, whichever is less.

- (2) The power consumption of EUT is less than 75W and no Limits apply.
- (3) Voltage Dip: 100% reduction – Performance Criteria B  
Voltage Dip: 30% reduction – Performance Criteria C  
Voltage Interruption: 100% Interruption – Performance Criteria C
- (4) For client's request and manual description, the test will not be executed.
- (5) "N/A" denotes test is not applicable in this Test Report.
- (6) "--" means "no" in this test report.

## 1.2 TEST LOCATION

Test Laboratory : Shenzhen United Testing Technology Co., Ltd.  
 Address : 2F, Annex Bldg, Jiahuangyuan Tech Park, #365 Baotian 1 Rd,  
 Tiegang Community, Xixiang Str, Bao'an District, Shenzhen, China

## 1.3 MEASUREMENT UNCERTAINTY

The reported uncertainty of measurement  $y \pm U$ , where expanded uncertainty  $U$  is based on a standard uncertainty multiplied by a coverage factor of  $k = 2$ , providing a level of confidence of approximately 95%.

### A. Conducted Measurement:

Test Site	Method	Measurement Frequency Range	U, (dB)	NOTE
UNI	CISPR 16-4-2	9kHz ~ 150kHz	2.96	--
		150kHz ~ 30MHz	2.44	--

### B. Radiated Measurement:

Test Site	Method	Measurement Frequency Range	U, (dB)	NOTE
UNI	CISPR 16-4-2	9kHz ~ 30MHz	2.50	--
		30MHz ~ 1000MHz	4.80	--
		1000MHz ~ 6000MHz	4.13	--

## 1.4 ENVIRONMENTAL CONDITIONS

During the measurement the environmental conditions were within the listed ranges:

Temperature:	15~35 °C
Relative Humidity:	30~60 %
Air Pressure:	86-106 kPa

## 2 GENERAL INFORMATION

### 2.1 GENERAL DESCRIPTION OF EUT

The following information of EUT submitted and identified by applicant:  
Transmitter/Receiver (TX/RX)

<b>Product:</b>	Wireless Headset
<b>Trade Name:</b>	N/A
<b>Main Model:</b>	X10S
<b>Additional Model:</b>	JH-TWS30
<b>Model Difference:</b>	All model's the function, software and electric circuit are the same, only with a product color and model named different. Test sample model: X10S.
<b>Frequency Range:</b>	BT: 2402~2480MHz
<b>Number of Channels:</b>	79CH
<b>Modulation Type:</b>	BR: <input checked="" type="checkbox"/> GFSK EDR: <input checked="" type="checkbox"/> π/4-DQPSK, <input checked="" type="checkbox"/> 8DPSK
<b>Bluetooth Version:</b>	V5.1
<b>Antenna designation:</b>	Internal Antenna
<b>Antenna Gain:</b>	3.0dBi
<b>Power supply:</b>	DC 5V by adapter DC 3.7V by battery
<b>Product Description:</b>	The EUT is a Wireless Headset.  Based on the application, features, or specification exhibited in User's Manual, more details of EUT technical specification, please refer to the User's Manual.

I/O Port Information (Applicable Not Applicable)

I/O Port Type	Number
USB	1



## 2.2 DESCRIPTION OF THE TEST MODES

No.	EMI Test mode description	Worst
1	Charging mode	V
2	BT mode	V
No.	EMS Test mode description	Worst
1	Charging mode	V
2	BT mode	V

Note: V means EMI worst mode.

## 2.3 DESCRIPTION OF TEST SETUP

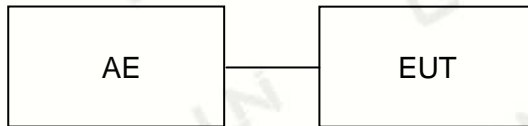

Note: The EUT tested system was configured as upper figure, unless otherwise a special operating condition is specified in the following during the testing.

## 2.4 DESCRIPTION TEST PERIPHERAL AND EUT PERIPHERAL

The EUT has been tested as an independent unit together with other necessary accessories or support units. The following support units or accessories were used to form a representative test configuration during the tests.

Item	Equipment	Mfr/Brand	Model/Type No.	Power Cable Length	Note
E-1	Wireless Headset	N/A	X10S	50cm	EUT
E-2	Adapter	Xiaomi	--	--	AE
E-3	Phone	HUAWEI	--	--	AE

Note:

1. The support equipment was authorized by Declaration of Confirmation.
2. All the above equipment/cables were placed in worse case positions to maximize emission signals during emission test.

## 2.5 MEASUREMENT INSTRUMENTS LIST

Item	Equipment	Manufacturer	Model No.	Serial No.	Calibrated until
Conduction Emissions Measurement					
1	Conducted Emission Test Software	EZ-EMC	Ver.CCS-3A1-CE	N/A	N/A
2	AMN	Schwarzbeck	NNLK8121	8121370	2022.09.22
3	AAN	TESEQ	T8-Cat6	38888	2022.09.22
4	Pulse Limiter	CYBRTEK	EM5010	E115010056	2023.05.17
5	EMI Test Receiver	Rohde&Schwarz	ESCI	101210	2022.09.22
Radiated Emissions Measurement					
1	Radiated Emission Test Software	EZ-EMC	Ver.CCS-03A1	N/A	N/A
2	Horn Antenna	Sunol	DRH-118	A101415	2023.09.27
3	Broadband Hybrid Antenna	Sunol	JB1	A090215	2024.02.26
4	PREAMP	HP	8449B	3008A00160	2022.09.22
5	PREAMP	HP	8447D	2944A07999	2023.05.17
6	EMI Test Receiver	Rohde&Schwarz	ESR3	101891	2022.09.22
7	MXA Signal Analyzer	Keysight	N9020A	MY51110104	2022.09.22
8	Active Loop Antenna	Com-Power	AL-310R	10160009	2023.07.25
9	Horn Antenna	Schwarzbeck	BBHA9120D	9120D-1680	2023.05.23
10	Horn Antenna	A-INFOMW	LB-180400-KF	J211060660	2022.09.27
11	Loop Antenna	Beijing daze Technology	ZN30401	13015	2022.09.22
12	EM Clamp	Schwarzbeck	MDS21	03350	2022.09.27
Harmonic / Flicker Measurement					
1	Power Analyzer	California Instrumnets	PACS-1	X71719	2022.11.29
2	AC Power Source	California Instrumnets	5001ix	HK53570	2022.09.22
Electrostatic Discharge Test					
1	ESD Generator	EVERFINE	EMS61000-2A	P185811CA837112 1	2022.09.23
RS Test					
1	Power Meter	Agilent	E4419B	QB4331226	2022.10.10
2	Power Sensor	Agilent	8481A	MY41092622	2022.10.10
3	Power Sensor	Agilent	8481A	US37296783	2022.10.10
4	Signal Generator	Agilent	N5182A	MY46240556	2022.10.10
5	Power Amplifier	MICOTOP	MPA-80-1000-250	1711489	2022.10.10
6	Power Amplifier	MICOTOP	MPA-1000-3000-7 5	1711488	2022.10.10
7	Power Amplifier	MICOTOP	MPA-3000-6000-5 0	MPA1706275	2022.10.10
8	Bilog Antenna	TESEQ	CBL6111D	34678	2022.10.10
9	Horn Antenna	Schwarzbeck	BBHA9120D	9120D-1680	2023.05.23

Item	Equipment	Manufacturer	Model No.	Serial No.	Calibrated until
<b>Electrical Fast Transient/Burst Immunity Test</b>					
1	EMS Test Control System	Shanghai Lioncel	SCU-614AS	SCU614S0160601	N/A
2	EFT/B Generator	Shanghai Lioncel	EFT-404S	EFT404S0160601	2022.09.22
<b>Surge Test</b>					
1	EMS Test Control System	Shanghai Lioncel	SCU-614AS	SCU614S0160601	N/A
2	Surge Generator	Shanghai Lioncel	LSG-506S	LSG506S0160601	2022.09.22
3	CDN	Shanghai Lioncel	CDN-532S	CDN532S0160601	2022.09.22
<b>CS Test</b>					
1	CS	SCHLODER	CDG-6000-25	126A1280/2014	2022.10.10
2	CDN	SCHLODER	CDN-M2+3	A2210275/2014	2022.10.10
3	EM Clamp	SCHLODER	EMCL-20	132A1283	2022.10.10
4	Attenuator	Nemtest	ATT-6DB-100	A100W224	2022.10.10
5	Audio Analyzer	R&S	UPL	100419	2022.10.10
6	Universal Radio Communication Tester	R&S	CMW500	117239	2022.10.10
7	Universal Radio Communication Tester	R&S	CMU200	111764	2022.10.10
8	Audio Analyzer	R&S	UPL	100689	2022.10.10
9	Audio Breakthrough Shielding Box	SKET	SB_ABT/C35	N/A	2022.10.10
10	Ear Simulator	SKET	AE_ABT/C35	N/A	2022.10.10
11	Mouth Simulator	SKET	AM_ABT/C35	N/A	2022.10.10
12	1KHz Standard Source	SKET	MSC_ABT/C35	N/A	2022.10.10
<b>Power-frequency magnetic fields Test</b>					
1	Magnetic Field Test System	Shanghai Lioncel	PMF801C-T	PMF801C-T016070 1	2022.11.18
<b>Voltage dips and interruptions Test</b>					
1	Voltage SAG Simulator	Shanghai Lioncel	VDS-1101	VDS11010160601	2022.09.22
2	Adjustable Power Supply	Shanghai Lioncel	RGL-210	RGL2100151001	N/A

### 3 CONDUCTED EMISSIONS MEASUREMENT

#### 3.1 CONDUCTED EMISSION LIMIT

Frequency (MHz)	Maximum RF Line Voltage(dB $\mu$ V)			
	CLASS A		CLASS B	
	Q.P.	Ave.	Q.P.	Ave.
0.15~0.50	79	66	66~56*	56~46*
0.50~5.00	73	60	56	46
5.00~30.0	73	60	60	50

Note:

- 1.The tighter limit applies at the band edges.
- 2.The limit of " \* " marked band means the limitation decreases linearly with the logarithm of the frequency in the range.

The following table is the setting of the receiver:

Receiver Parameters	Setting
Attenuation	10 dB
Start Frequency	0.15 MHz
Stop Frequency	30 MHz
IF Bandwidth	9 kHz

#### 3.2 TEST SETUP

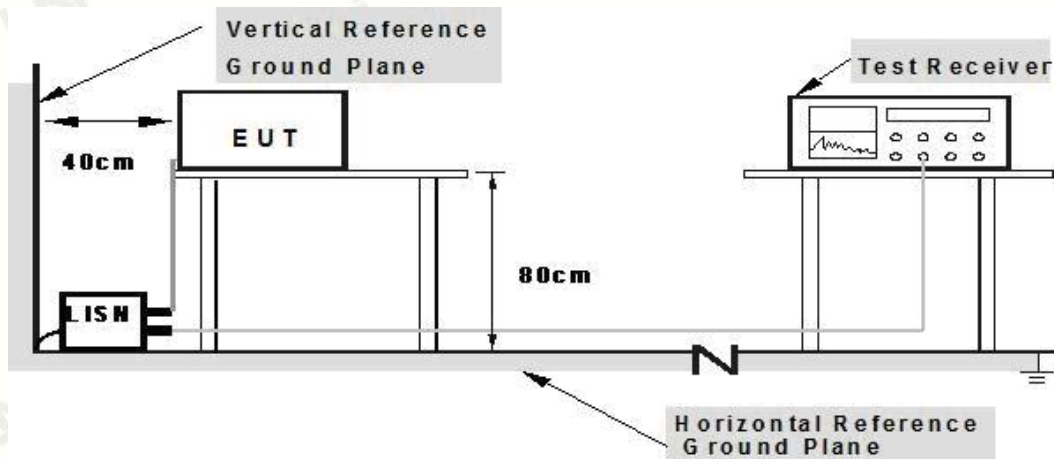

- Note: 1.Support units were connected to second LISN.**  
**2.Both of LISNs (AMN) are 80 cm from EUT and at least 80 from other units and other metal planes**

### 3.3 TEST PROCEDURE

- 1.The EUT was placed 0.4 meters from the horizontal ground plane with EUT being connected to the power mains through a line impedance stabilization network (LISN). All other support equipments powered from additional LISN(s). The LISN provide 50 Ohm/ 50uH of coupling impedance for the measuring instrument.
- 2.Interconnecting cables that hang closer than 40 cm to the ground plane shall be folded back and forth in the center forming a bundle 30 to 40 cm long.
- 3.I/O cables that are not connected to a peripheral shall be bundled in the center. The end of the cable may be terminated, if required, using the correct terminating impedance. The overall length shall not exceed 1 m.
- 4.For the actual test configuration, please refer to the related Item EUT Test Photos.

### 3.4 TEST RESULT

PASS



Temperature:	24°C	Relative Humidity:	48%
Test Voltage:	AC 230V, 50Hz	Pressure:	1010hPa
Test Mode:	Mode 1	Phase:	Line

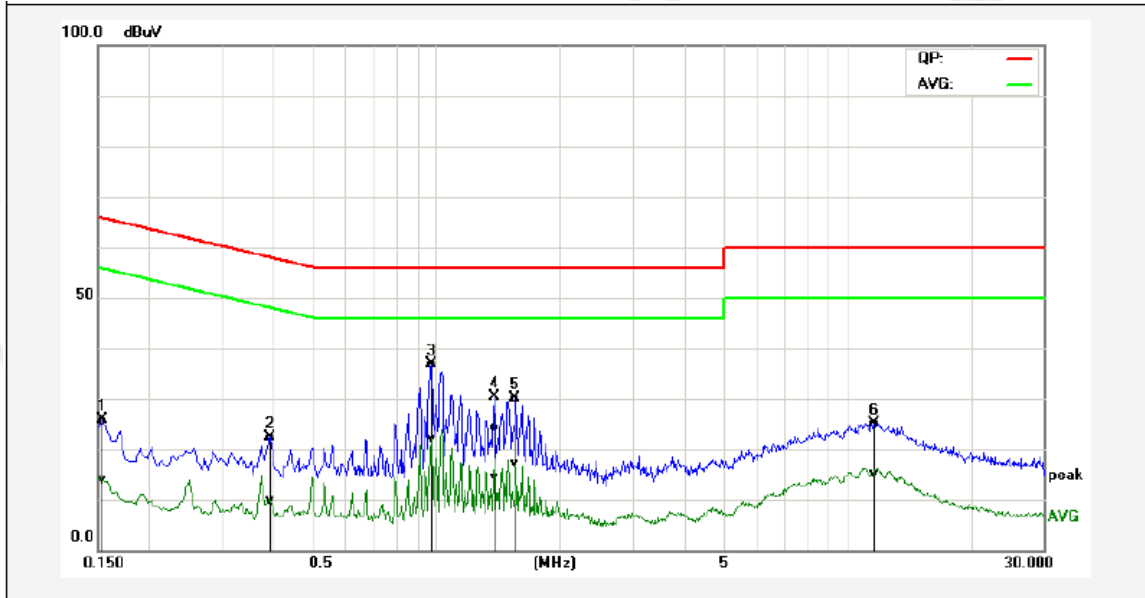

No.	Frequency (MHz)	QuasiPeak reading (dBuV)	Average reading (dBuV)	Correction factor (dB)	QuasiPeak result (dBuV)	Average result (dBuV)	QuasiPeak limit (dBuV)	Average limit (dBuV)	QuasiPeak margin (dB)	Average margin (dB)	Remark
1P	0.1540	15.74	3.80	10.01	25.75	13.81	65.78	55.78	-40.03	-41.97	Pass
2P	0.3940	12.50	-0.10	10.00	22.50	9.90	57.98	47.98	-35.48	-38.08	Pass
3*	0.9740	26.76	12.12	10.02	36.78	22.14	56.00	46.00	-19.22	-23.86	Pass
4P	1.3820	14.41	4.25	10.06	24.47	14.31	56.00	46.00	-31.53	-31.69	Pass
5P	1.5580	20.01	7.24	10.01	30.02	17.25	56.00	46.00	-25.98	-28.75	Pass
6P	11.5860	15.04	4.93	10.15	25.19	15.08	60.00	50.00	-34.81	-34.92	Pass

Remark: Factor = Insertion Loss + Cable Loss, Result = Reading + Factor, Margin = Result – Limit.

Temperature:	24°C	Relative Humidity:	48%
Test Voltage:	AC 230V, 50Hz	Pressure:	1010hPa
Test Mode:	Mode 1	Phase:	Neutral

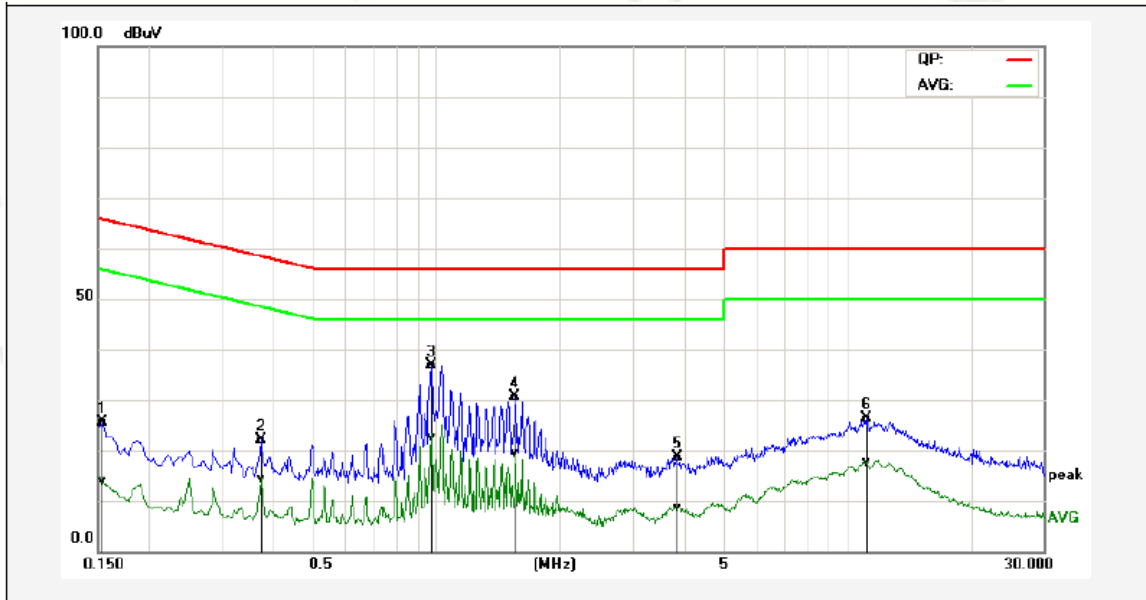

No.	Frequency (MHz)	QuasiPeak reading (dBuV)	Average reading (dBuV)	Correction factor (dB)	QuasiPeak result (dBuV)	Average result (dBuV)	QuasiPeak limit (dBuV)	Average limit (dBuV)	QuasiPeak margin (dB)	Average margin (dB)	Remark
1P	0.1540	15.60	3.79	10.01	25.61	13.80	65.78	55.78	-40.17	-41.98	Pass
2P	0.3740	12.06	4.50	9.99	22.05	14.49	58.41	48.41	-36.36	-33.92	Pass
3*	0.9740	26.82	12.51	10.02	36.84	22.53	56.00	46.00	-19.16	-23.47	Pass
4P	1.5580	20.69	9.27	10.01	30.70	19.28	56.00	46.00	-25.30	-26.72	Pass
5P	3.8540	8.62	-1.44	10.06	18.68	8.62	56.00	46.00	-37.32	-37.38	Pass
6P	11.1940	16.21	7.59	10.12	26.33	17.71	60.00	50.00	-33.67	-32.29	Pass

Remark: Factor = Insertion Loss + Cable Loss, Result = Reading + Factor, Margin = Result – Limit.

## 4 RADIATED EMISSIONS MEASUREMENT

### 4.1 RADIATION EMISSION LIMIT

Below 1000MHz:

Frequency (MHz)	Class A		Class B	
	10m	3m	10m	3m
	dBuV/m	dBuV/m	dBuV/m	dBuV/m
30~230	40	50	30	40
230~1000	47	57	37	47

Above 1000MHz:

Frequency (MHz)	Class A		Class B	
	PK	AV	PK	AV
	dBuV/m	dBuV/m	dBuV/m	dBuV/m
1000~3000	76	56	70	50
3000~6000	80	60	74	54

Note:

1. The tighter limit applies at the band edges.
2. Emission level (dBuV/m) = 20log Emission level (uV/m).

### 4.2 TEST SETUP

#### 1. Radiated Emission Test-Up Frequency Below 1000MHz

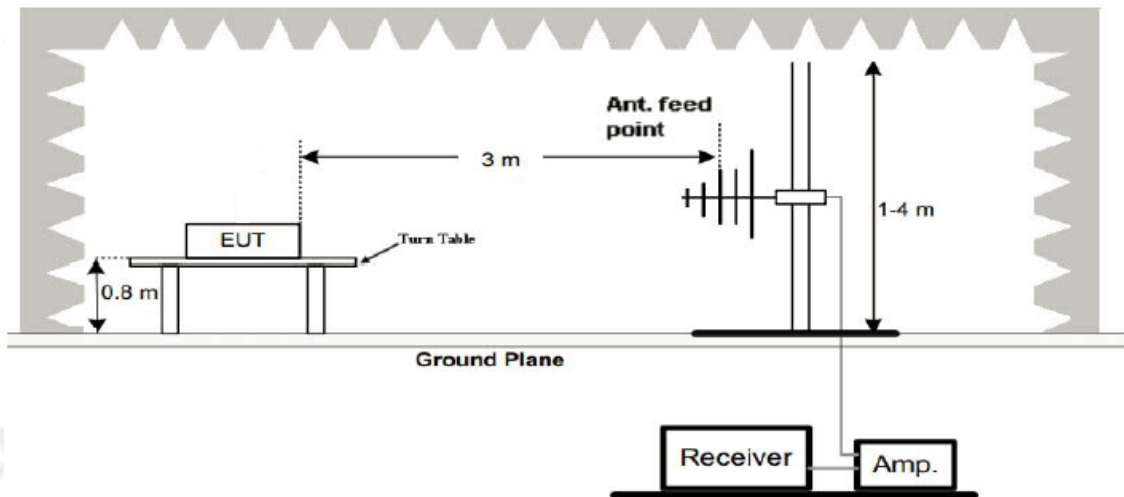

## 2. Radiated Emission Test-Up Frequency Above 1000MHz

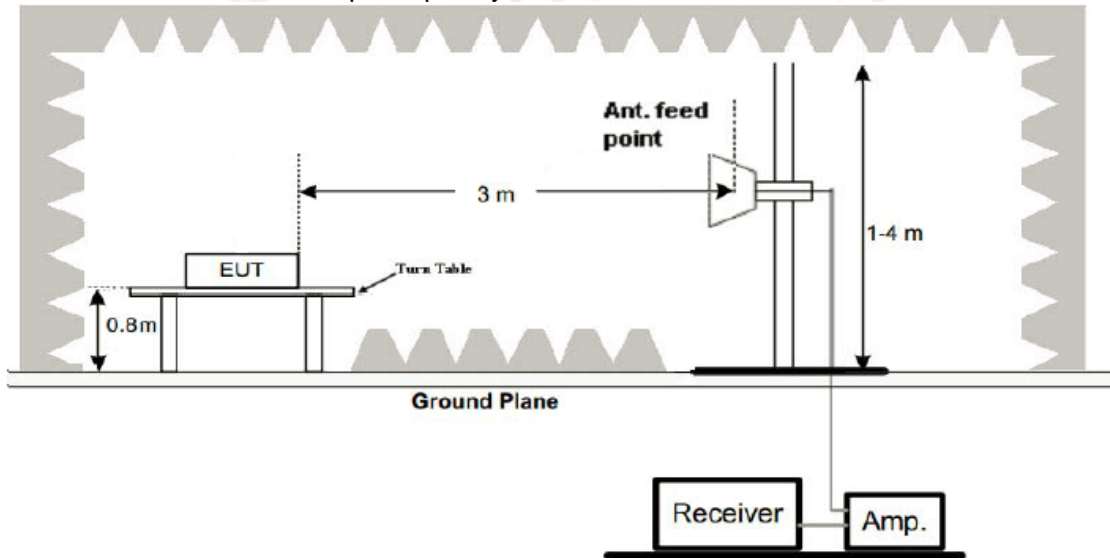

### 4.3 TEST PROCEDURE

1. The EUT was placed on the top of a rotating table 0.8 meters above the ground at a 3 meter semi-anechoic chamber room. The table was rotated 360 degrees to determine the position of the highest radiation.
2. The EUT was set 3 meters away from the interference-receiving antenna, which was mounted on the top of a variable-height antenna tower.
3. The height of antenna is varied from 1 meter to 4 meters above the ground to determine the maximum value of the field strength. Both horizontal and vertical polarizations of the antenna are set to make the measurement.
4. For each suspected emission, the EUT was arranged to its worst case and then the antenna was tuned to heights from 1 meter to 4 meters and the rotatable table was turned from 0 degrees to 360 degrees to find the maximum reading.
5. The test-receiver system was set to quasi-peak detect function and specified bandwidth with maximum hold mode when the test frequency is below 1GHz.
6. For the actual test configuration, please refer to the related Item EUT Test Photos.

### 4.4 TEST RESULT

PASS

Below 1000MHz Test Results:

Temperature:	24°C	Relative Humidity:	48%
Test Voltage:	AC 230V, 50Hz	Pressure:	1010hPa
Test Mode:	Mode 1	Polarization:	Horizontal

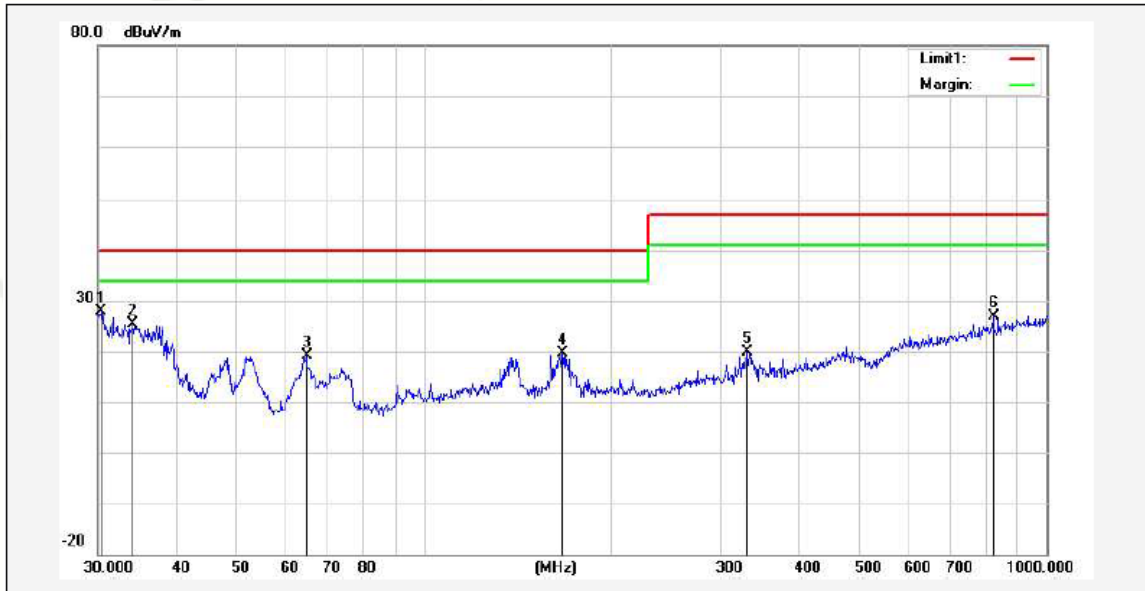

No.	Frequency (MHz)	Reading (dBuV)	Correction factor(dB/m)	Result (dBuV/m)	Limit (dBuV/m)	Margin (dB)	Degree (deg.)	Height (cm)	Remark
1*	30.3173	34.81	-6.86	27.95	40.00	-12.05			peak
2	34.1561	35.19	-9.76	25.43	40.00	-14.57			peak
3	64.8865	39.76	-20.53	19.23	40.00	-20.77			peak
4	167.2368	35.13	-15.50	19.63	40.00	-20.37			peak
5	330.1949	32.64	-12.67	19.97	47.00	-27.03			peak
6	821.7104	30.41	-3.42	26.99	47.00	-20.01			peak



Temperature:	24°C	Relative Humidity:	48%
Test Voltage:	AC 230V, 50Hz	Pressure:	1010hPa
Test Mode:	Mode 1	Polarization:	Vertical

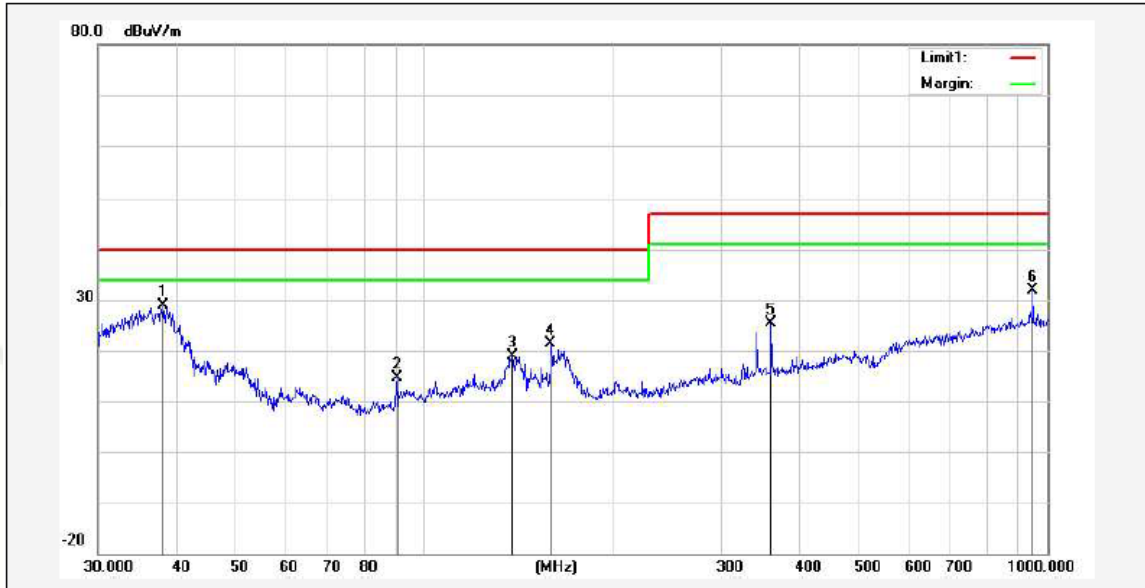

No.	Frequency (MHz)	Reading (dBuV)	Correction factor(dB/m)	Result (dBuV/m)	Limit (dBuV/m)	Margin (dB)	Degree (deg.)	Height (cm)	Remark
1*	38.2120	41.84	-13.04	28.80	40.00	-11.20			peak
2	90.5374	34.48	-19.73	14.75	40.00	-25.25			peak
3	138.8735	33.72	-14.85	18.87	40.00	-21.13			peak
4	159.7844	36.73	-15.36	21.37	40.00	-18.63			peak
5	360.4477	37.20	-11.87	25.33	47.00	-21.67			peak
6	948.7610	33.67	-1.76	31.91	47.00	-15.09			peak

Remark: Result = Reading Level + Factor, Margin = Result – Limit  
 Factor = Ant. Factor + Cable Loss – Pre-amplifier

Temperature:	24°C	Relative Humidity:	48%
Test Voltage:	DC 3.7V	Pressure:	1010hPa
Test Mode:	Mode 2	Polarization:	Horizontal

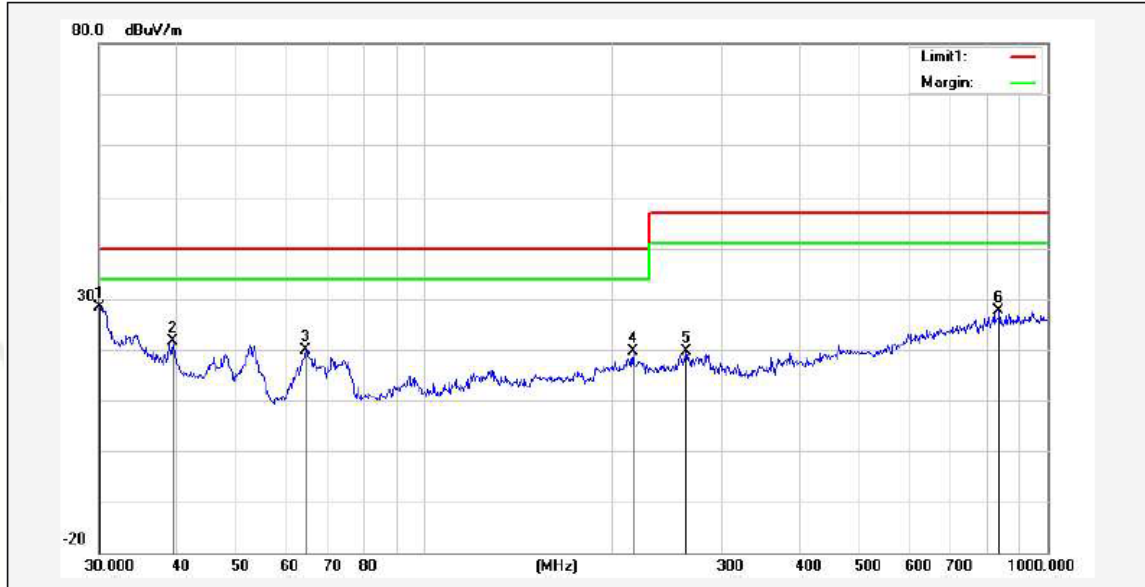

No.	Frequency (MHz)	Reading (dBuV)	Correction factor(dB/m)	Result (dBuV/m)	Limit (dBuV/m)	Margin (dB)	Degree (deg.)	Height (cm)	Remark
1*	30.1054	34.97	-6.70	28.27	40.00	-11.73			peak
2	39.4372	35.57	-14.03	21.54	40.00	-18.46			peak
3	64.4331	40.51	-20.59	19.92	40.00	-20.08			peak
4	216.0240	35.44	-15.76	19.68	40.00	-20.32			peak
5	262.8955	33.48	-13.86	19.62	47.00	-27.38			peak
6	836.2443	30.74	-3.09	27.65	47.00	-19.35			peak

Temperature:	24°C	Relative Humidity:	48%
Test Voltage:	DC 3.7V	Pressure:	1010hPa
Test Mode:	Mode 2	Polarization:	Vertical

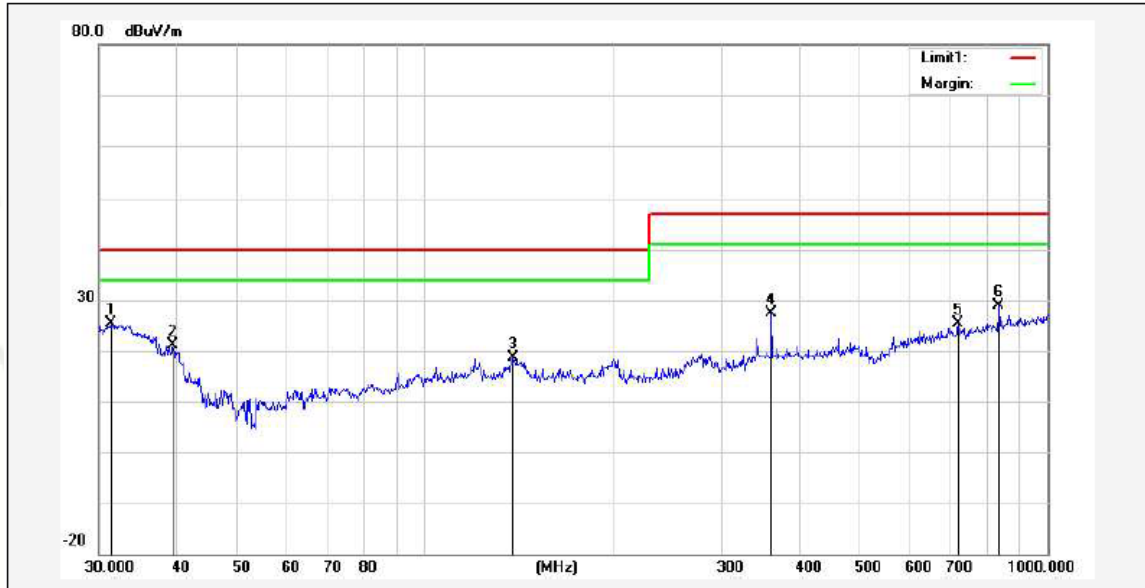

No.	Frequency (MHz)	Reading (dBuV)	Correction factor(dB/m)	Result (dBuV/m)	Limit (dBuV/m)	Margin (dB)	Degree (deg.)	Height (cm)	Remark
1*	31.3992	33.54	-8.15	25.39	40.00	-14.61			peak
2	39.4371	35.66	-14.57	21.09	40.00	-18.91			peak
3	138.3873	34.60	-16.03	18.57	40.00	-21.43			peak
4	360.4476	41.26	-13.92	27.34	47.00	-19.66			peak
5	719.1994	33.65	-8.33	25.32	47.00	-21.68			peak
6	836.2441	35.12	-6.28	28.84	47.00	-18.16			peak

Remark: Result = Reading Level + Factor, Margin = Result – Limit  
 Factor = Ant. Factor + Cable Loss – Pre-amplifier

Above 1000MHz Test Results:

Note: The peak value is too low against the limit, so the test data is not record.

## 5 HARMONICS CURRENT

### 5.1 HARMONICS CURRENT LIMIT

Limits for Class A Equipment	
Harmonics Order n	Max. permissible harmonic current (A)
<b>Odd harmonics</b>	
3	2.30
5	1.14
7	0.77
9	0.40
11	0.33
13	0.21
15≤n≤39	0.15×15/n
2	1.08
4	0.43
6	0.30
8≤n≤40	0.23×8/n

**Note:**

1. According to section 5 of EN IEC 61000-3-2: 2019, the EUT is Class A equipment.
2. The above limits are for all applications having an active input power>75W. No limits apply for equipment with an active input power up to and including 75W.

## 5.2 TEST SETUP

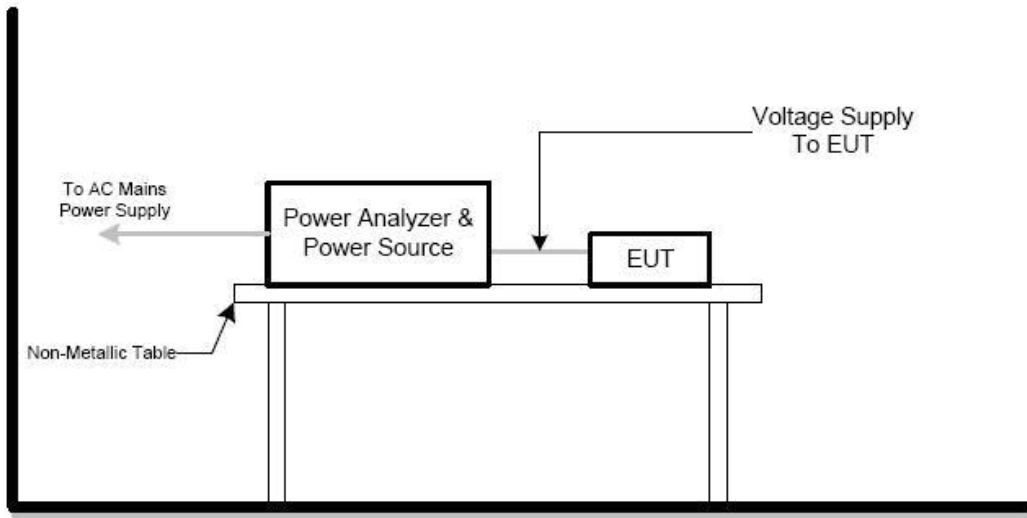

## 5.3 TEST PROCEDURE

1. The EUT was placed on the top of a wooden table 0.8 meters above the ground and operated to produce the maximum harmonic components under normal operating conditions.
2. The classification of EUT is according to section 5 of EN IEC 61000-3-2. The EUT is classified as follows:
  - Class A: Balanced three-phase equipment, Household appliances excluding equipment as Class D, Tools excluding portable tools, Dimmers for incandescent lamps, audio equipment, equipment not specified in one of the three other classes.
  - Class B: Portable tools. Portable tools.; Arc welding equipment which is not professional equipment.
  - Class C: Lighting equipment.
  - Class D: Equipment having a specified power less than or equal to 600W of the following types: Personal computers and personal computer monitors and television receivers.
3. The correspondent test program of test instrument to measure the current harmonic emanated from EUT is chosen. The measure time shall be not less than the time necessary for the EUT to be exercised.

## 5.4 TEST RESULT

N/A

Note: The above limits for all equipment except for lighting equipment having an active input power > 75 W and no limits apply for equipment with an active input power up to and including 75W.



## 6 VOLTAGE FLUCTUATION AND FLICKERS

### 6.1 VOLTAGE FLUCTUATION AND FLICKERS LIMIT

Tests	Limit	Descriptions
	EN 61000-3-3	
Pst	$\leq 1.0, T_p= 10 \text{ min.}$	Short Term Flicker Indicator
Plt	$\leq 0.65, T_p=2 \text{ hr.}$	Long Term Flicker Indicator
Tdt(s)	$\leq 3.3\%$	Relative Steady-State V-Chang
dmax(%)	$\leq 4\%$	Maximum Relative V-Chang
dc(%)	$\leq 3.3\%$ for $> 500 \text{ ms}$	Relative V-change Characteristic

### 6.2 TEST SETUP

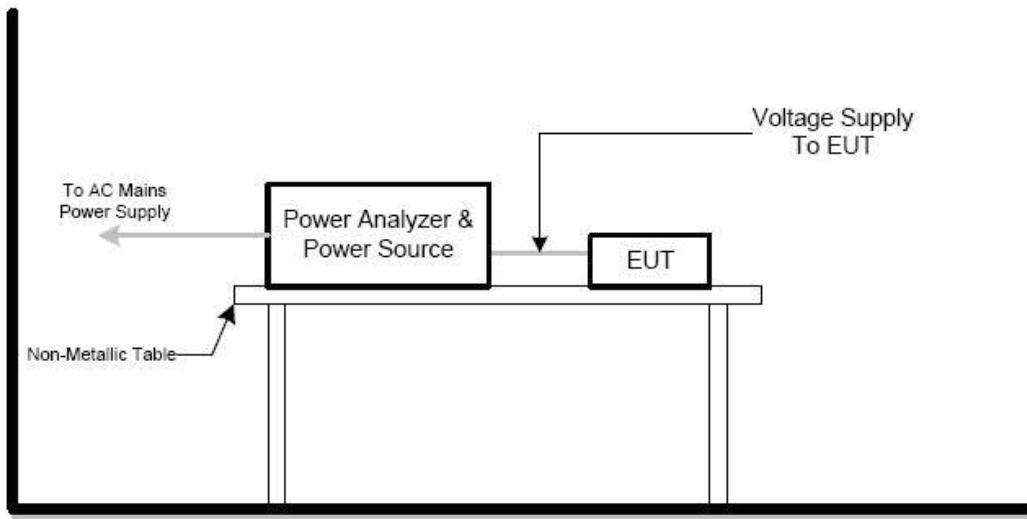

### 6.3 TEST PROCEDURE

1. Fluctuation and Flickers Test:

Tests was performed according to the Test Conditions/Assessment of Voltage Fluctuations specified in Clause 6.0/4.0 of EN 61000-3-3 depend on which standard adopted for compliance measurement.

2. All types of voltage fluctuation in this report are assessed by direct measurement using flicker-meter.

### 6.4 TEST RESULT

Temperature:	22°C	Relative Humidity:	48%
Test Voltage:	AC 230V, 50Hz	Pressure:	1010hPa
Test Mode:	Mode 1		

Test Parameter	Measurement Value	Limit	Result
Pst	0.04	1.0	Pass
Plt	0.01	0.65	Pass
Tdt(s)	0.02	0.5	Pass
dmax(%)	0.13%	4%	Pass
dc(%)	0.09%	3.3%	Pass

## 7 EMC IMMUNITY TEST

### 7.1 DESCRIPTION OF PERFORMANCE CRITERIA

The performance criteria are used to take a decision on whether a radio equipment passes or fails immunity tests.

For the purpose of the present document two categories of performance criteria apply:

- Performance criteria for continuous phenomena.
- Performance criteria for transient phenomena.

### 7.2 GENERAL PERFORMANCE CRITERIA

#### 7.2.1 Performance criteria for continuous phenomena

During the test, the equipment shall:

- continue to operate as intended;
- not unintentionally transmit;
- not unintentionally change its operating state;
- not unintentionally change critical stored data.

#### 7.2.2 Performance criteria for transient phenomena

For all ports and transient phenomena with the exception described below, the following applies:

- The application of the transient phenomena shall not result in a change of the mode of operation (e.g. unintended transmission) or the loss of critical stored data.
- After application of the transient phenomena, the equipment shall operate as intended.

For surges applied to symmetrically operated wired network ports intended to be connected directly to outdoor lines the following criteria applies:

- For products with only one symmetrical port intended for connection to outdoor lines, loss of function is allowed, provided the function is self-recoverable, or can be otherwise restored. Information stored in non-volatile memory, or protected by a battery backup, shall not be lost.
- For products with more than one symmetrical port intended for connection to outdoor lines, loss of function on the port under test is allowed, provided the function is self-recoverable. Information stored in non-volatile memory, or protected by a battery backup, shall not be lost.

For a 0 % residual voltage dip tests the following performance criteria apply:

- The performance criteria for transient phenomena shall apply.

For a 70 % residual voltage dip and voltage interruption tests, the following performance criteria apply:

- in the case where the equipment is fitted with or connected to a battery back-up, the performance criteria for transient phenomena shall apply;
- in the case where the equipment is powered solely from the AC mains supply (without the use of a parallel battery back-up) volatile user data may have been lost and if applicable the communication link need not to be maintained and lost functions should be recoverable by user or operator;
- no unintentional responses shall occur at the end of the test, when the voltage is restored to nominal;
- in the event of loss of function(s) or in the event of loss of user stored data, this fact shall be recorded.

### 7.3 Performance Table

EN 301 489-17 Performance criteria		
Criteria	During Test	After Test (i.e. as a result of the application of the test)
A	Shall operate as intended. (see note). Shall be no loss of function. Shall be no unintentional transmissions.	Shall operate as intended. Shall be no degradation of performance. Shall be no loss of function. Shall be no loss of critical stored data.
B	May be loss of function.	Functions shall be self-recoverable. Shall operate as intended after recovering. Shall be no loss of critical stored data.
C	May be loss of function.	Functions shall be recoverable by the operator. Shall operate as intended after recovering. Shall be no loss of critical stored data.
<p>The performance criteria A shall apply for continuous phenomena.                      The performance criteria B shall apply for transient phenomena, except for voltage dips greater than or equal to 100 ms and voltage interruptions of 5 000 ms duration, for which performance criteria C shall apply.                      Where the EUT is a transmitter in standby mode or receive mode, unintentional transmission shall not occur during the test.</p>		
<p>Note: Operate as intended during the test allows a level of degradation in accordance with the Minimum performance level.</p>		
<b>Minimum performance level</b>		
<p>For equipment that supports a PER or FER, the minimum performance level shall be a PER or FER less than or equal to 10 %.                      For equipment that does not support a PER or a FER, the minimum performance level shall be no loss of the wireless transmission function needed for the intended use of the equipment.</p>		

## 8 ELECTROSTATIC DISCHARGE IMMUNITY TEST (ESD)

### 8.1 TEST SPECIFICATION

Basic Standard:	EN 61000-4-2
Discharge Impedance:	330 ohm / 150 pF
Required Performance:	B
Discharge Voltage:	Air Discharge: 2kV/4kV/8kV (Direct) Contact Discharge: 2kV/4kV (Direct/Indirect)
Polarity:	Positive & Negative
Number of Discharge:	Air Discharge: min. 20 times at each test point Contact Discharge: min. 200 times in total
Discharge Mode:	Single Discharge
Discharge Period:	1 second minimum

### 8.2 TEST SETUP

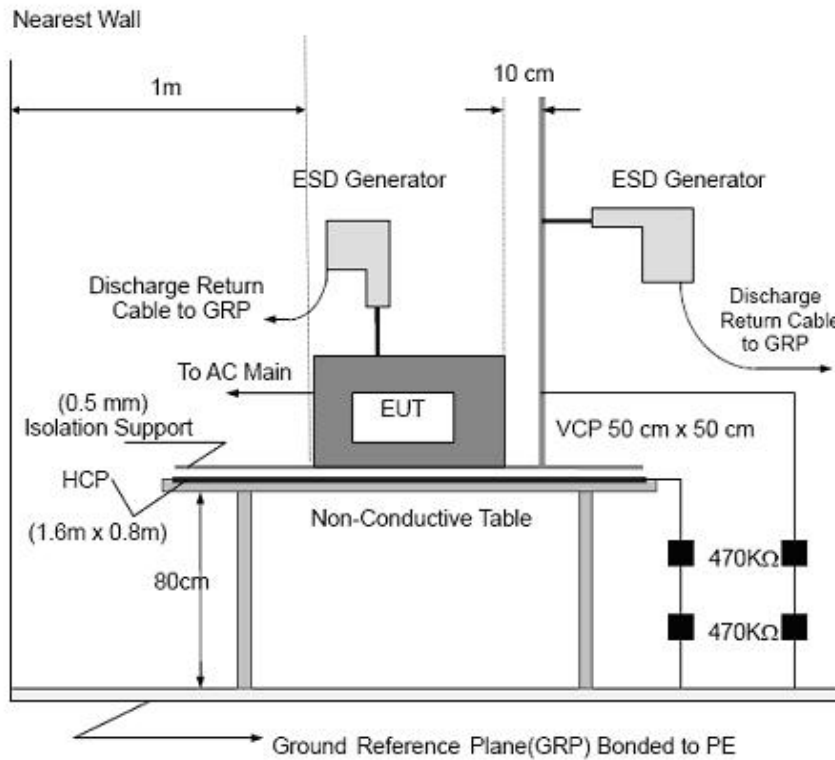



Note:

### TABLE-TOP EQUIPMENT

The configuration consisted of a wooden table 0.8 meters high standing on the Ground Reference Plane. The GRP consisted of a sheet of aluminum at least 0.25mm thick. A Horizontal Coupling Plane (1.6m x 0.8m) was placed on the table and attached to the GRP by means of a cable with 940kΩ total impedance. The equipment under test, was installed in a representative system as described in section 7 of EN 61000-4-2, and its cables were placed on the HCP and isolated by an insulating support of 0.5mm thickness. A distance of 0.8-meter minimum was provided between the EUT and the walls of the laboratory and any other metallic structure.

### FLOOR-STANDING EQUIPMENT

The equipment under test was installed in a representative system as described in section 7 of EN 61000-4-2, and its cables were isolated from the Ground Reference Plane by an insulating support of 0.1 meter thickness. The GRP was consisted of a sheet of aluminum that is at least 0.25mm thick, and extended at least 0.5 meters from the EUT on all sides.

## 8.3 TEST PROCEDURE

The test generator necessary to perform direct and indirect application of discharges to the EUT in the following manners:

1. Electrostatic discharges were applied only to those points and surfaces of the EUT that are accessible to users during normal operation. The test was performed with at least ten single discharges on the pre-selected points in the most sensitive polarity.

The time interval between two successive single discharges was at least 1 second.

The ESD generator was held perpendicularly to the surface to which the discharge was applied and the return cable was at least 0.2 meters from the EUT.

Contact discharges were applied to the non-insulating coating, with the pointed tip of the generator penetrating the coating and contacting the conducting substrate.

Air discharges were applied with the round discharge tip of the discharge electrode approaching the EUT as fast as possible (without causing mechanical damage) to touch the EUT. After each discharge, the ESD generator was removed from the EUT and re-triggered for a new single discharge. The test was repeated until all discharges were complete.

Vertical Coupling Plane (VCP):

The coupling plane, of dimensions 0.5m x 0.5m, is placed parallel to, and positioned at a distance 0.1m from, the EUT, with the Discharge Electrode touching the coupling plane.

The four faces of the EUT will be performed with electrostatic discharge.

Horizontal Coupling Plane (HCP):

The coupling plane is placed under to the EUT. The generator shall be positioned vertically at a distance of 0.1m from the EUT, with the Discharge Electrode touching the coupling plane.

The four faces of the EUT will be performed with electrostatic discharge.

2. Air discharges at insulation surfaces of the EUT.

It was at least ten single discharges with positive and negative at the same selected point.

### 8.4 TEST RESULT

Temperature:	22°C	Relative Humidity:	48%
Test Voltage:	AC 230V, 50Hz DC 3.7V	Pressure:	1010hPa
Test Mode:	Mode 1 and Mode 2		

Times of Discharge	Voltage	Coupling	Test Performance	Performance Result	Result (Pass/Fail)
Mini 25 / Point	±4kV	Contact Discharge	No function loss	A	Pass
Mini 25 / Point	±4kV	Indirect Discharge HCP (Front)	No function loss	A	Pass
Mini 25 / Point	±4kV	Indirect Discharge HCP (Left)	No function loss	A	Pass
Mini 25 / Point	±4kV	Indirect Discharge HCP (Back)	No function loss	A	Pass
Mini 25 / Point	±4kV	Indirect Discharge HCP (Right)	No function loss	A	Pass
Mini 25 / Point	±4kV	Indirect Discharge VCP (Front)	No function loss	A	Pass
Mini 25 / Point	±4kV	Indirect Discharge VCP (Left)	No function loss	A	Pass
Mini 25 / Point	±4kV	Indirect Discharge VCP (Back)	No function loss	A	Pass
Mini 25 / Point	±4kV	Indirect Discharge VCP (Right)	No function loss	A	Pass
Mini 25 / Point	±8kV	Air Discharge	No function loss	A	Pass

## 9 RADIATED, RADIO-FREQUENCY, ELECTROMAGNETIC FIELD IMMUNITY TEST (RS)

### 9.1 TEST SPECIFICATION

Basic Standard:	EN 61000-4-3
Required Performance:	A
Frequency Range:	80 MHz ~ 6000 MHz
Field Strength:	3 V/m
Modulation:	1kHz Sine Wave, 80%, AM Modulation
Frequency Step:	1 % of fundamental
Polarity of Antenna:	Horizontal and Vertical
Test Distance:	3 m
Antenna Height:	1.55 m
Dwell Time:	$1.5 \times 10^{-3}$ decade/s

### 9.2 TEST SETUP

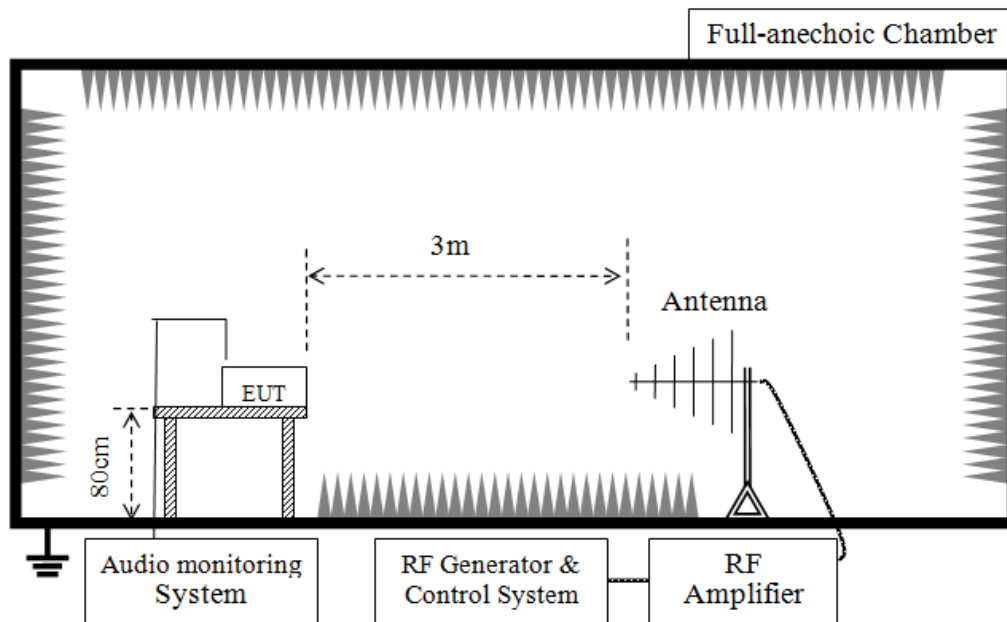

Note:

**TABLE-TOP EQUIPMENT**

The EUT installed in a representative system as described in section 7 of EN 61000-4-3 was placed on a non-conductive table 0.8 meters in height. The system under test was connected to the power and signal wire according to relevant installation instructions.

**FLOOR-STANDING EQUIPMENT**

The EUT installed in a representative system as described in section 7 of EN 61000-4-3 was placed on a non-conductive wood support 0.1 meters in height. The system under test was connected to the power and signal wire according to relevant installation instructions.

**9.3 TEST PROCEDURE**

The EUT and support equipment, which are placed on a table that is 0.8 meter above ground and the testing was performed in a fully-anechoic chamber.

The testing distance from antenna to the EUT was 3 meters.

The other condition need as following manners:

- 1.The frequency range is swept from 80 MHz to 6000 MHz with the signal 80% amplitude modulated with a 1kHz sine wave. The rate of sweep did not exceed  $1.5 \times 10^{-3}$  decade/s. Where the frequency range is swept incrementally, the step size was 1% of fundamental.
- 2.The dwell time at each frequency shall be not less than the time necessary for the EUT to be able to respond.
- 3.The test was performed with the EUT exposed to both vertically and horizontally polarized fields on each of the four sides.

**9.4 TEST RESULT**

Temperature:	22°C	Relative Humidity:	48%
Test Voltage:	AC 230V, 50Hz DC 3.7V	Pressure:	1010hPa
Test Mode:	Mode 1 and Mode 2		

Frequency Range (MHz)	RF Field Position	R.F. Field Strength	Azimuth	Performance Result	Result (Pass/Fail)
80~6000	H / V	3 V/m (rms) AM Modulated 1000Hz, 80%	Front	A	PASS
			Rear		
			Left		
			Right		

Note: "A" stand for, during test, operate as intended no loss of function, no degradation of performance, no unintentional transmissions and after test, no degradation of performance, no loss of function, no loss of stored data or user programmable functions.

- 1) N/A - denotes test is not applicable in this test report.
- 2) Criteria A: There was no change operated with initial operating during the test.
- 3) Criteria B: The EUT function loss during the test, but self-recoverable after the test.
- 4) Criteria C: The system shut down during the test.

## 10 ELECTRICAL FAST TRANSIENT IMMUNITY TEST (EFT)

### 10.1 TEST SPECIFICATION

Basic Standard:	EN 61000-4-4
Required Performance:	B
Test Voltage:	Power Line: 1 KV Signal/Control Line: 0.5 KV
Polarity:	Positive & Negative
Impulse Frequency:	5 kHz
Impulse Wave shape:	5/50 ns
Burst Duration:	15 ms
Burst Period:	300 ms
Test Duration:	Not less than 2 min.

### 10.2 TEST SETUP

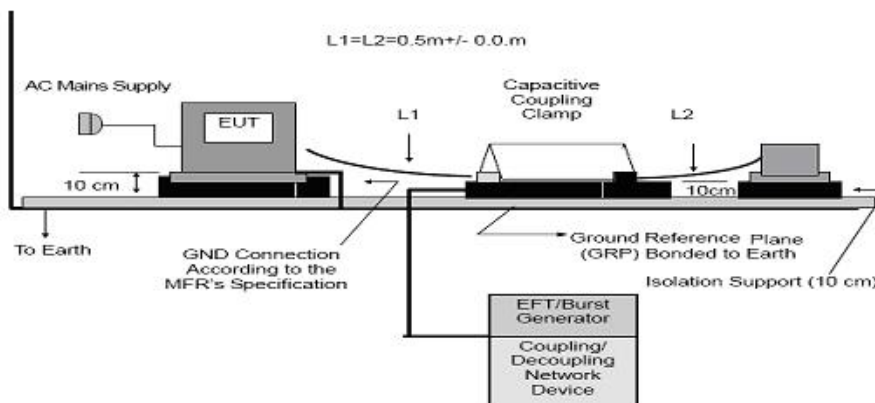
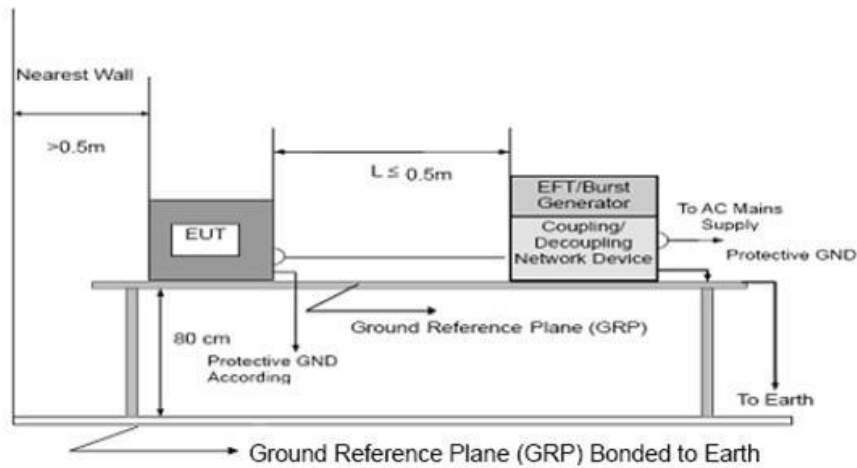



Note:

### TABLE-TOP EQUIPMENT

Table-top equipment and equipment normally mounted on ceilings or walls as well as built-in equipment shall be tested with the EUT located ( $0.1 \pm 0.01$ ) m above the ground reference plane.

Testing of large table-top equipment or multiple systems can be performed on the floor; maintaining the same distances as for the test setup of table-top equipment.

The test generator and the coupling/decoupling network shall be bonded to the ground reference plane.

The ground reference plane shall be a metallic sheet (copper or aluminium) of 0.25 mm minimum thickness; other metallic materials may be used, but they shall have at least 0.65 mm minimum thickness.

The minimum size of the ground reference plane is 0.8 m x 1 m. The actual size depends on the dimensions of the EUT.

The ground reference plane shall project beyond the EUT by at least 0.1 m on all sides.

The ground reference plane shall be connected to protective earth (PE) for safety reasons.

The EUT shall be arranged and connected to satisfy its functional requirements, according to the equipment installation specifications.

The minimum distance between the EUT and all other conductive structures (including the generator, AE and the walls of a shielded room), except the ground reference plane, shall be more than 0.5 m.

All cables to the EUT shall be placed on the insulation support 0.1 m above the ground reference plane.

Cables not subject to electrical fast transients shall be routed as far as possible from the cable under test to minimize the coupling between the cables.

The EUT shall be connected to the earthing system in accordance with the manufacturer's installation specifications; no additional earthing connections are allowed.

The connection impedance of the coupling/decoupling network earth cables to the ground reference plane and all bondings shall provide a low inductance.

Either a direct coupling network or a capacitive clamp shall be used for the application of the test voltages. The test voltages shall be coupled to all of the EUT ports in turn including those between two units of equipment involved in the test, unless the length of the interconnecting cable makes it impossible to test.

### FLOOR-STANDING EQUIPMENT

When using the coupling clamp, the minimum distance between the coupling plates and all other conductive surfaces (including the generator), except the ground reference plane beneath the coupling clamp and beneath the EUT, shall be at least 0.5 m.

The distance between any coupling devices and the EUT shall be ( $0.5 - 0/+0.1$ ) m for table-top equipment testing, and ( $1.0 \pm 0.1$ ) m for floor standing equipment, unless otherwise specified in product standards. When it is not physically possible to apply the distances mentioned above, other distances can be used and shall be recorded in the test report.

The cable between the EUT and the coupling device, if detachable, shall be as short as possible to comply with the requirements of this clause. If the manufacturer provides a cable exceeding the distance between the coupling device and the point of entry of the EUT, the excess length of this cable shall be bundled and situated at a distance of 0.1 m above the ground reference plane. When a capacitive clamp is used as a coupling device, the excess cable length shall be bundled at the AE side.

Parts of the EUT with interconnecting cables of a length less than 3 m, which are not tested, shall be placed on the insulating support. The parts of the EUT shall have a distance of 0.5 m between them. Excess cable length shall be bundled.

### 10.3 TEST PROCEDURE

The EUT and support equipment, are placed on a table that is 0.8 meter&0.1 meter above a metal ground plane measured 1m\*1m min.

The ground reference plane shall be a metallic sheet (copper or aluminium) of 0.25 mm minimum thickness; other metallic materials may be used, but they shall have at least 0.65 mm minimum thickness.

The other condition need as following manners:

1. The length of power cord between the coupling device and the EUT should not exceed 1 meter.
2. Both positive and negative polarity discharges were applied.
3. The duration time of each test sequential was 2 minute.

### 10.4 TEST RESULT

Temperature:	22°C	Relative Humidity:	48%
Test Voltage:	AC 230V, 50Hz	Pressure:	1010hPa
Test Mode:	Mode 1		

Coupling Line		Test level (kV)								Performance Result	Result (Pass/Fail)
		0.5		1		2		4			
		+	-	+	-	+	-	+	-		
AC line	L			A	A					A	PASS
	N			A	A						PASS
	PE										N/A
	L+N			A	A						PASS
	L+PE										N/A
	N+PE										N/A
	L+N+PE										N/A
DC Line										N/A	
Signal Line										N/A	

## 11 SURGE IMMUNITY TEST (SURGE)

### 11.1 TEST SPECIFICATION

Basic Standard:	EN 61000-4-5
Required Performance:	B
Wave-Shape:	Combination Wave 1.2/50 us Open Circuit Voltage
Test Voltage:	Power line ~ line to line: 1kV line to ground: 2kV Telecommunication line: 0.5kV DC network power port:0.5kV
Surge Input/Output:	L-N, L-PE, N-PE
Generator Source:	(L-N)2 ohm between networks
Impedance:	(L-PE, N-PE)12 ohm between network and ground
Polarity:	Positive/Negative
Phase Angle:	0 /90/180/270°
Pulse Repetition Rate:	1 time / min. (maximum)
Number of Tests:	5 positive and 5 negative at selected points

### 11.2 TEST SETUP

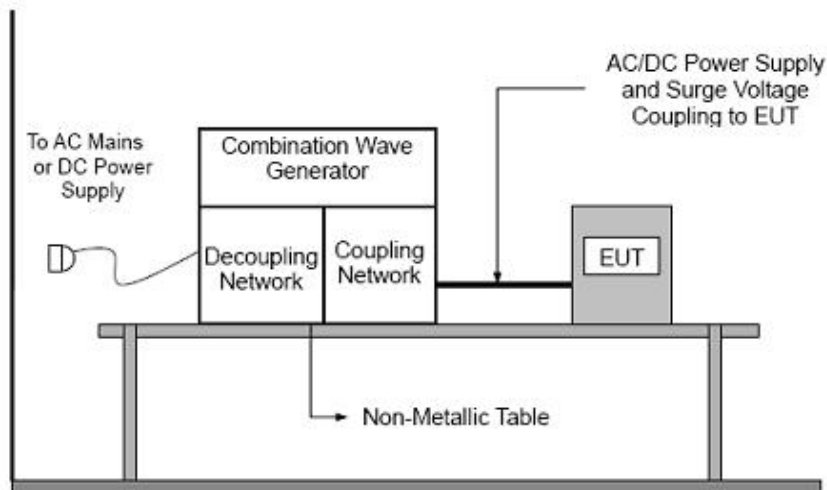

### 11.3 TEST PROCEDURE

1. For EUT power supply:
2. The surge is to be applied to the EUT power supply terminals via the capacitive coupling network. Decoupling networks are required in order to avoid possible adverse effects on equipment not under test that may be powered by the same lines, and to provide sufficient decoupling impedance to the surge wave. The power cord between the EUT and the coupling/decoupling networks shall be 2 meters in length (or shorter).
3. For test applied to unshielded unsymmetrically operated interconnection lines of EUT:
4. The surge is applied to the lines via the capacitive coupling. The coupling /decoupling networks shall not influence the specified functional conditions of the EUT. The interconnection line between the EUT and the coupling/decoupling networks shall be 2 meters in length (or shorter).

### 11.4 TEST RESULT

Temperature:	22°C	Relative Humidity:	48%
Test Voltage:	AC 230V, 50Hz	Pressure:	1010hPa
Test Mode:	Mode 1		

Coupling Line			Test level								Performance Result	Result (Pass/Fail)
			0.5 kV		1 kV		2 kV		4 kV			
			+	-	+	-	+	-	+	-		
AC line	L-N	0°			A	A					A	PASS
		90°			A	A						
		180°			A	A						
		270°			A	A						
	L-PE	0°										N/A
		90°										
		180°										
		270°										
	N-PE	0°										N/A
		90°										
		180°										
		270°										
DC Line											N/A	
Signal Line											N/A	

# 12 CONDUCTED RADIO FREQUENCY DISTURBANCES IMMUNITY TEST (CS)

## 12.1 TEST SPECIFICATION

Basic Standard:	EN 61000-4-6
Required Performance:	A
Frequency Range:	0.15 MHz ~ 80 MHz
Field Strength:	3 V
Modulation:	1kHz Sine Wave, 80%, AM Modulation
Frequency Step:	1 % of fundamental
Dwell Time:	$1.5 \times 10^{-3}$ decade/s

## 12.2 TEST SETUP

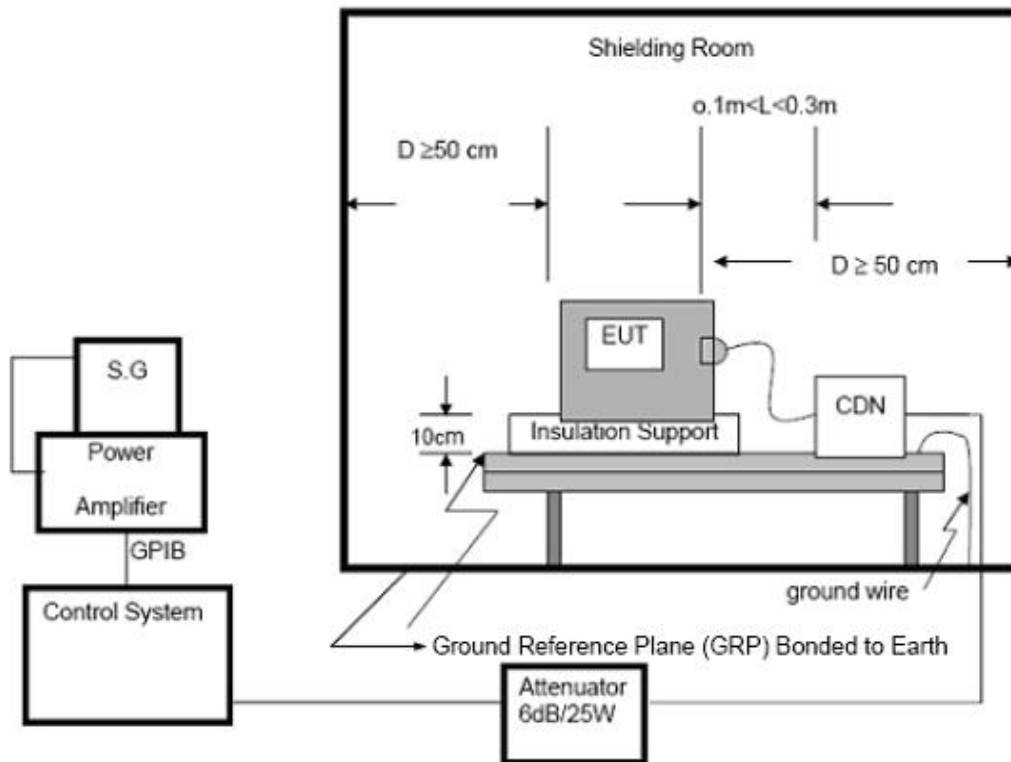

Note:

### FLOOR-STANDING EQUIPMENT

The equipment to be tested is placed on an insulating support of 0.1 meters height above a ground reference plane. All relevant cables shall be provided with the appropriate coupling and decoupling devices at a distance between 0.1 meters and 0.3 meters from the projected geometry of the EUT on the ground reference plane.



### 12.3 TEST PROCEDURE

The EUT and support equipment, are placed on a table that is 0.8 meter&0.1 meter above a metal ground plane measured 1m\*1m min.

The other condition need as following manners:

- 1.The EUT shall be tested within its intended operating and climatic conditions.
- 2.An artificial hand was placed on the hand-held accessory and connected to the ground reference plane.
- 3.One of the CDNs not used for injection was terminated with 50Ω, providing only one return path. All other CDNs were coupled as decoupling networks.
4. The frequency range is swept from 150 kHz to 80 MHz, using the signal level established during the setting process and with a disturbance signal of 80 % amplitude. The signal is modulated with a 1 kHz sine wave, pausing to adjust the RF signal level or the switch coupling devices as necessary. Where the frequency is swept incrementally, the step size shall not exceed 1% of the preceding frequency value.
5. The dwell time of the amplitude modulated carrier at each frequency shall not be less than the time necessary for the EUT to be exercised and to respond, but shall in no case be less than 0.5 s. The sensitive frequencies (e.g. clock frequencies) shall be analyzed separately.
6. Attempts should be made to fully exercise the EUT during testing, and to fully interrogate all exercise modes selected for susceptibility.

### 12.4 TEST RESULT

Temperature:	22°C	Relative Humidity:	48%
Test Voltage:	AC 230V, 50Hz	Pressure:	1010hPa
Test Mode:	Mode 1		

Test Ports (Mode)	Freq. Range (MHz)	Field Strength	Performance Result	Result (Pass/Fail)
Input/ Output AC. Power Port	0.15 ~ 80	3V (rms) AM Modulated 1000Hz, 80%	A	PASS
Input/ Output DC. Power Port	0.15 ~ 80		N/A	N/A
Signal Line	0.15 ~ 80		N/A	N/A

Note: "A" stand for, during test, operate as intended no loss of function, no degradation of performance, no unintentional transmissions and after test, no degradation of performance, no loss of function, no loss of stored data or user programmable functions.

## 13 POWER FREQUENCY MAGNETIC FIELD IMMUNITY TEST (PFMF)

### 13.1 TEST SPECIFICATION

Basic Standard:	EN 61000-4-8
Required Performance:	A
Frequency Range:	50Hz
Field Strength:	3 A/m
Observation Time:	1 minute
Inductance Coil:	Rectangular type, 1mx1m

### 13.2 TEST SETUP

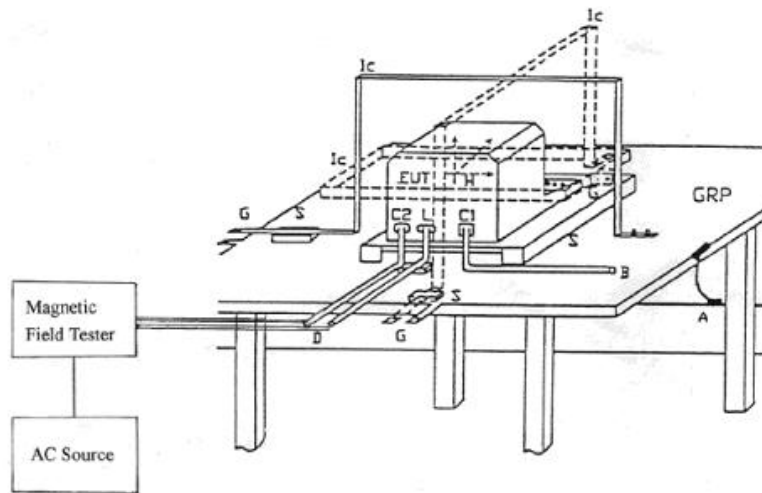

Note:

#### TABLE-TOP EQUIPMENT

The equipment shall be subjected to the test magnetic field by using the induction coil of standard dimension (1 m x 1 m). The induction coil shall then be rotated by 90 degrees in order to expose the EUT to the test field with different orientations.

#### FLOOR-STANDING EQUIPMENT

The equipment shall be subjected to the test magnetic field by using induction coils of suitable dimensions. The test shall be repeated by moving and shifting the induction coils, in order to test the whole volume of the EUT for each orthogonal direction. The test shall be repeated with the coil shifted to different positions along the side of the EUT, in steps corresponding to 50 % of the shortest side of the coil. The induction coil shall then be rotated by 90 degrees in order to expose the EUT to the test field with different orientations.

### 13.3 TEST PROCEDURE

The EUT and support equipment, are placed on a table that is 0.8 meter&0.1 meter above a metal ground plane measured 1m\*1m min.

The other condition need as following manners:

- 1.The equipment cabinets shall be connected to the safety earth directly on the GRP via the earth terminal of the EUT.
- 2.The cables supplied or recommended by the equipment manufacturer shall be used. 1 meterof all cables used shall be exposed to the magnetic field.

### 13.4 TEST RESULT

Temperature:	22°C	Relative Humidity:	48%
Test Voltage:	AC 230V, 50Hz DC 3.7V	Pressure:	1010hPa
Test Mode:	Mode 1 and Mode 2		

Test Mode	Test Level (A/m)	Inductive Coil	Duration(s)	Performance Result	Result
Enclosure	3	X	60	A	PASS
Enclosure	3	Y	60	A	PASS
Enclosure	3	Z	60	A	PASS

## 14 VOLTAGE INTERRUPTION/DIPS IMMUNITY TEST (DIPS)

### 14.1 TEST SPECIFICATION

Basic Standard:	ENIEC 61000-4-11
Required Performance:	B (For 100% Voltage Dips, 0.5 Cycle) B (For 100% Voltage Dips, 1 Cycle) C (For 30% Voltage Dips, 25 Cycles) C (For 100% Voltage Interruptions, 250 Cycles)
Test Duration Time:	Minimum three test events in sequence
Interval between Event:	Minimum ten seconds
Phase Angle:	0°/45°/90°/135°/180°/225°/270°/315°/360°
Test Cycle:	3 times

### 14.2 TEST SETUP

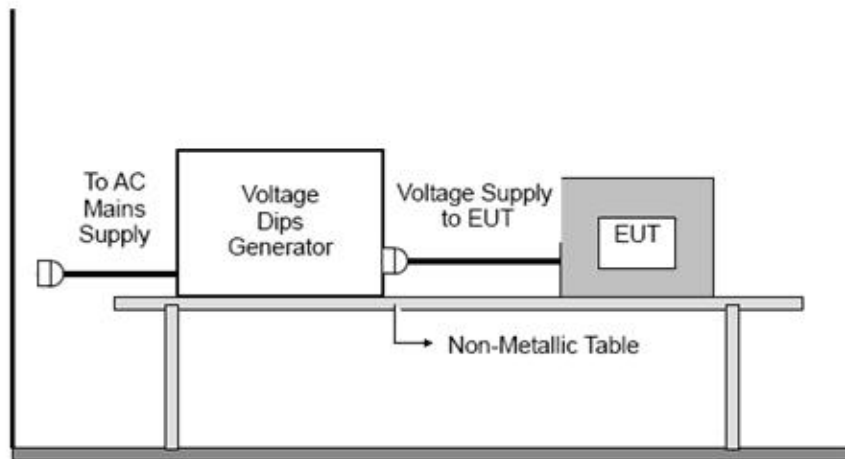

### 14.3 TEST PROCEDURE

The EUT shall be tested for each selected combination of test levels and duration with a sequence of three dips/interruptions with intervals of 10 s minimum (between each test event). Each representative mode of operation shall be tested. Abrupt changes in supply voltage shall occur at zero crossings of the voltage waveform.

### 14.4 TEST RESULT

Temperature:	22°C	Relative Humidity:	48%
Test Voltage:	AC 230V, 50Hz	Pressure:	1010hPa
Test Mode:	Mode 1		

Voltage Reduction	Duration (cycle)	Times	Interval (Sec)	Result (Pass/Fail)
Voltage dip 0%	0.5	3	10	PASS
Voltage dip 0%	1	3	10	PASS
Voltage dip 70%	25	3	10	PASS
Voltage interruptions	250	3	10	PASS

A: No degradation in the performance of the EUT was observed.

B: Stop charging during the test and self-recoverable after test.

C: Lost functions can be recoverable by user or operator.



### 15 PHOTO OF EUT



PHOTO 01



PHOTO 02



PHOTO 03



PHOTO 04



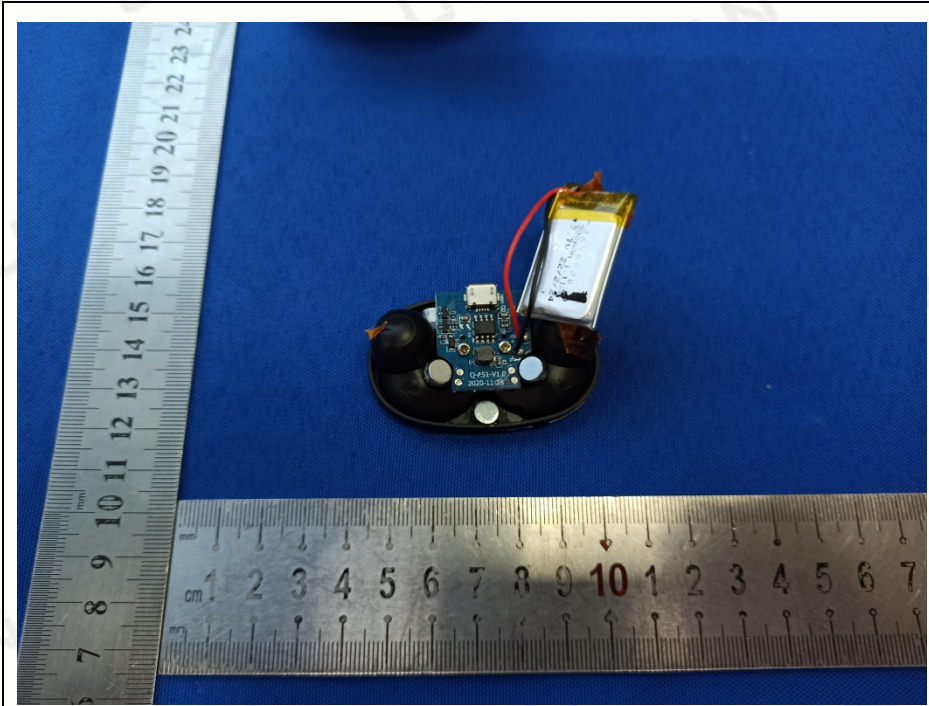

PHOTO 05

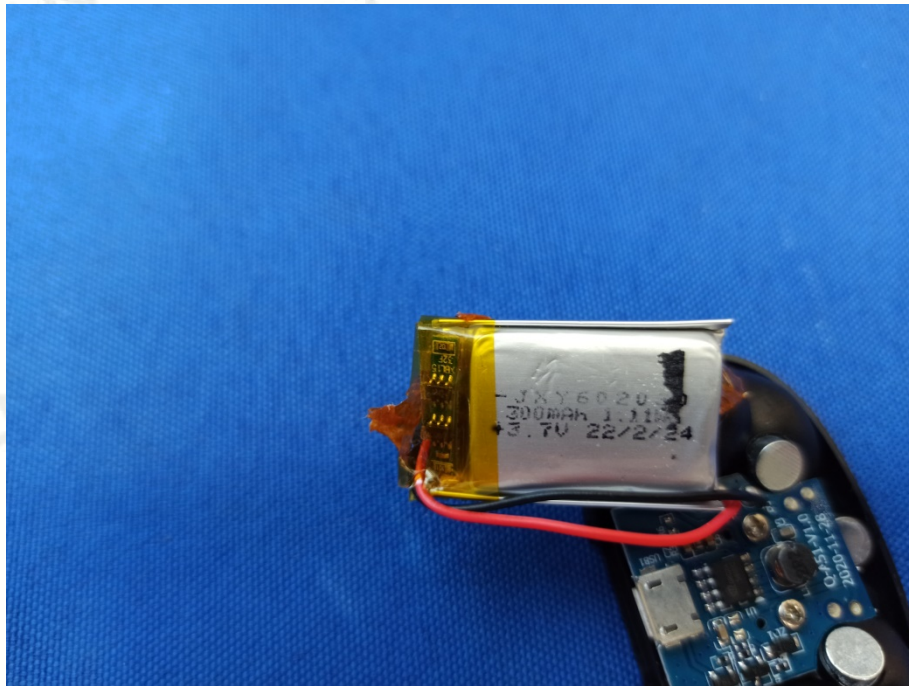

PHOTO 06

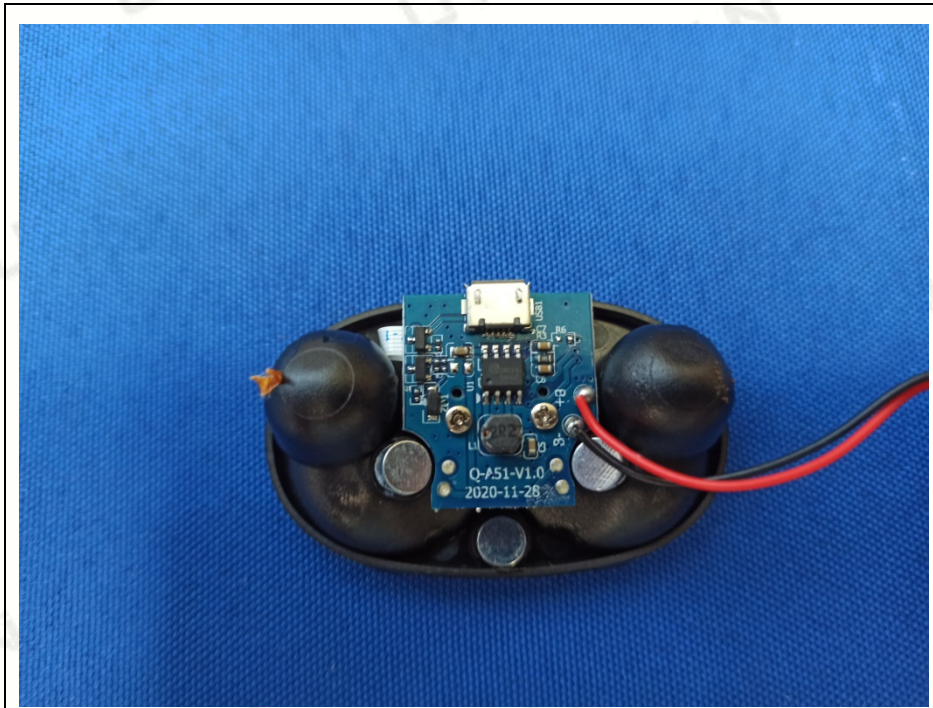

PHOTO 07

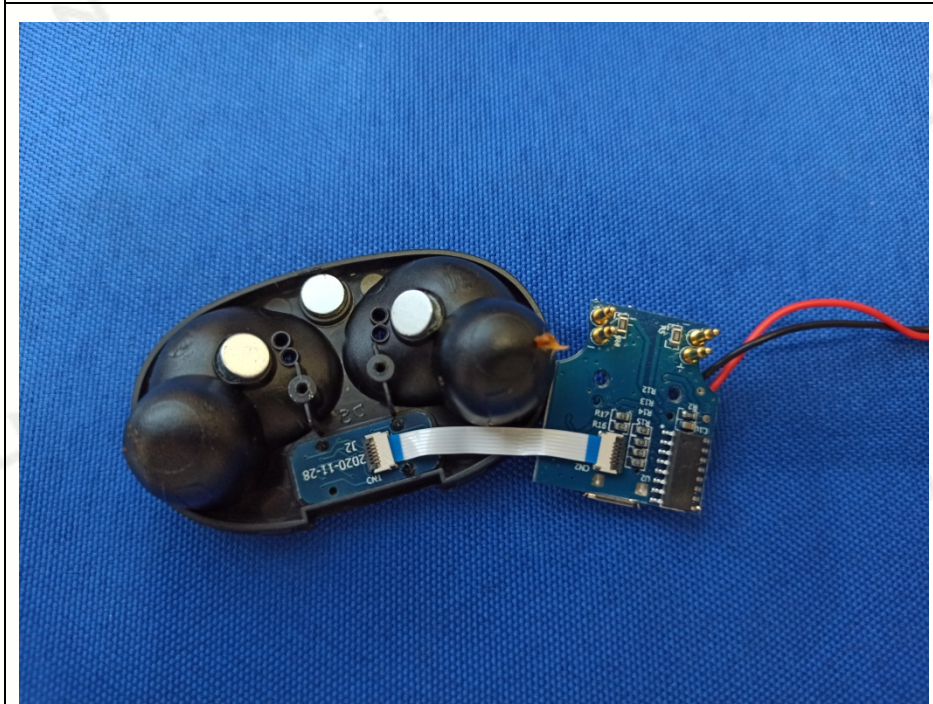

PHOTO 08





PHOTO 09



PHOTO 10



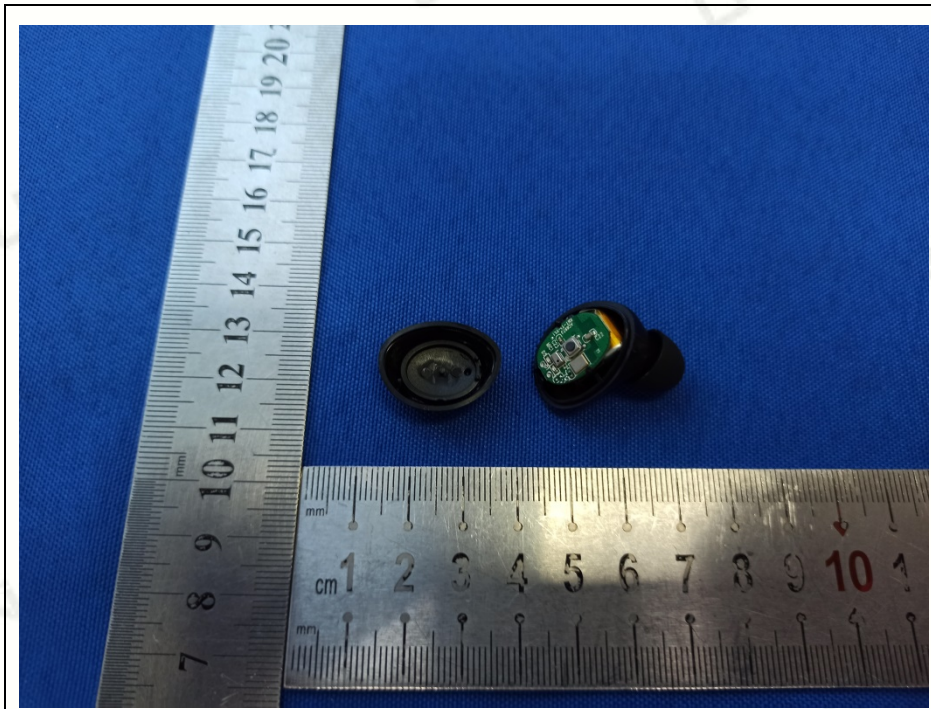

PHOTO 11

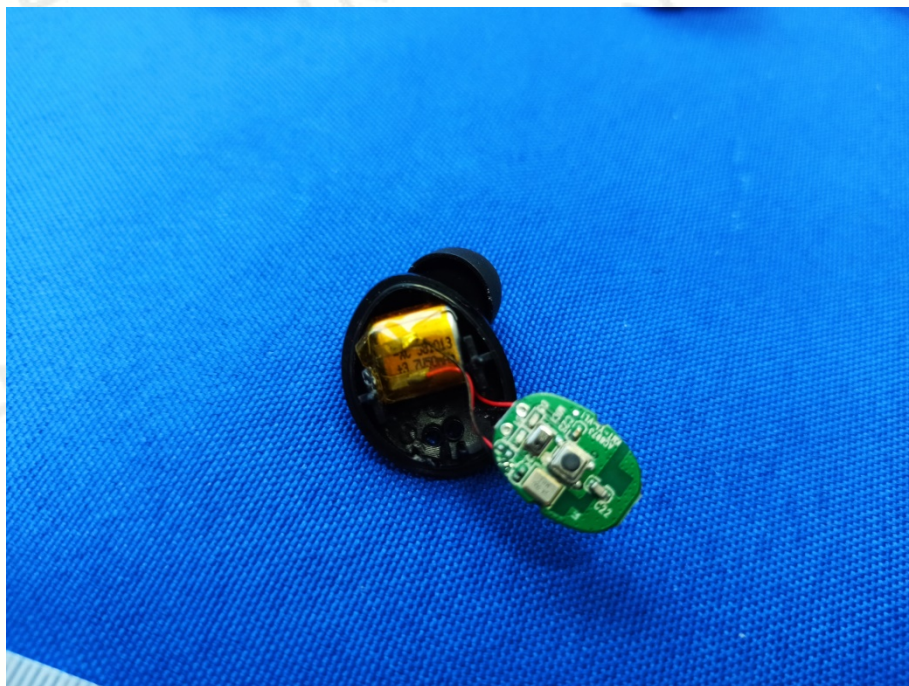

PHOTO 12

### 16 PHOTO OF TEST



PHOTO 01



PHOTO 02





PHOTO 03



PHOTO 04



\*\*\*End of Report\*\*\*

## Statement

- 1.This report must have the signature of the authorized signatory and the special seal of the report, otherwise it will be considered invalid.If there is no anti-counterfeiting electronic seal of the laboratory in the report in PDF format or it is displayed as "x", the report is invalid.
- 2.This report shall not be modified, added or deleted without authorization.
- 3.The results of this report are only valid for the EUT provided by Applicant to our laboratory for inspection (That is,EUT received by our laboratory.Without special explanation, it refers to the samples presented in the report "PHOTO OF EUT").
- 4.If there is any objection to the test data and conclusions of this report, please submit it in writing within 10 working days after the date of issuance of the report.
- 5.Without the written consent of the laboratory, this report shall not be copied (except for full copy), nor shall it be used as publicity materials or advertising.
- 6.The cover of the report is for decoration only, not included in the body of the report.
- 7.The paper report issued by our laboratory has the same effect as the electronic report. In case of any difference between the two, the electronic report shall prevail.
- 8.The Chinese and English reports issued by our laboratory have the same effect. In case of any difference in understanding, the Chinese version shall prevail.
- 9.Please provide the complete report documents issued by our laboratory when inquiring the report.
- 10.For cases where compliance is determined based on test values, when relevant specifications, standards, documents, and customers have no relevant requirements and no other special instructions, the test report issued by this laboratory is carried out in full value and adopts ILAC-G8:09 /2019 "Simple Acceptance Rule" for judgment.
- 11.In the People's Republic of China, when there is no CMA Accredited Symbol in this report, the report is only for scientific research, teaching or internal quality control activities.